



DURHAM REGION CLIMATE RESILIENCE STANDARD FOR NEW HOUSES

February 2018
Draft for consultation

Durham Region Climate Resilience Standard for New Houses

A Standard to improve the disaster resilience of new low-rise residential buildings in the Region of Durham

Submitted to Brian Kelly, Manager of Sustainability

February 2018

Draft for consultation

V 1.1

Authors:

- Part A: Basement Flood Protection authored by Dan Sandink (ICLR)
- Part B: Tornado/Extreme Wind Protection authored by Dan Sandink and Gregory Kopp (Western University)
- Part C: Extreme Heat Protection authored by Sophie Guilbault (ICLR), Holly Wacker (ICLR) and Dan Sandink

Cover image credits:

Top left: New home construction in Ajax, ON. D. Sandink, ICLR. 2016.

Top right: Basement flood impacts in Binbrook, ON. D. Sandink, ICLR. 2012.

Bottom left: Tornado Damage in Angus, ON. G. Kopp, Western U., 2014.

Bottom right: New home construction in Ajax, ON. D. Sandink, ICLR. 2016.

Table of Contents

Introduction.....	1
Part A: Basement Flood Protection.....	3
Basement Flood Hazards	4
New Construction and Basement Flood Risk Reduction	4
Inflow/Infiltration in New Development	5
Limiting, Sealing Foundation Openings	6
Site Grading, Drainage and Low Impact Development (LID) Features	6
Foundation Drainage, Sump Pump and Downspout Discharge and Drainage	7
Sewer Backflow Protection.....	9
Generator Connection Rough-Ins	10
Construction and Inspection Issues.....	10
Basement Flood Protection Measures	11
Basement Flood Protection Measures (Primary).....	12
Basement Flood Protection Measures (Enhanced)	23
Part B: Extreme Wind/Tornado Protection	25
Construction and Inspection Issues.....	26
Extreme Wind Protection Measures	28
Appendix B1: Gable End Wall Support and Bracing Options.....	33
Part C: Extreme Heat Protection	37
Heat Resilience in Canada.....	37
Design Strategies for Passive Cooling	38
Urban Planning Approaches for Heat Resilience	39
Developing a Strong Basis for Prescriptive Building Envelope Performance Requirements	40
Overview of Extreme Heat Protection Measures	41
Extreme Heat Protection Measures (Primary).....	42
Extreme Heat Protection Measures (Enhanced)	46
Appendix C1: Envelope Insulation and Airtightness Performance Examples	47
Appendix C2: Overview of Energy Efficiency/Building Envelope Initiatives	50
Definitions	56
References and End Notes	58

Acknowledgments

The authors would like to acknowledge the significant input and support provided by members of the Technical Committees involved in the development of this Standard (see below). The authors would also like to thank Claudio Zicarelli (Flood Prevention Advisor, Edmonton), Peter Marra (Director of Public Works, Town of LaSalle), Mark Guderjan (Chief Plumbing & Gas Inspector, City of Calgary), Andrew Lee (Total Power), Marco Civitarese (CBO and Manager, Building Regulations, City of Calgary), Monir Moniruzzaman (Senior Project Manager, City of Hamilton), Alex Sandovski (Municipal Sales Engineer, IPEX Inc.), Larry Gill (Manager Codes and Standards, IPEX Management Inc.), Kevin Tudhope (City of Toronto), Lisa King (Senior Policy Planner, City Planning Division, City of Toronto), Victor Gallant (Epidemiologist, Climate Change and Innovation Bureau, Health Canada) and Gregory Richardson (Senior Policy Analyst, Health Canada) for their assistance with the completion of this report. Further, from the City of Victoriaville, we would like to thank Martin Lessard (Managing Director), Serge Cyr (Director, Environment), Carline Ghazal (Coordinator, Sustainable Development Division), H  l  ne Plante (Environmental Technician, Sustainable Development Division), and Michel Marleau (Environmental Technician, Sustainable Development Division). While the authors greatly appreciate the time and input provided by those listed here, errors and omissions in the document are the responsibilities of the authors alone.

Basement Flood Technical Committee:

- Andrew Binns (Asst. Professor, School of Engineering, University of Guelph)
- Marcella Bondie Keenan (Program Director, Center for Neighbourhood Technology)
- Anita DeVries (Executive Officer, Durham Region Home Builders Association)
- Chris Dinsmore (Senior Civil Engineer, East Bay Municipal Urban District)
- Marvin Ingebrigtsen (Infrastructure and Development Supervisor, City of Welland)
- Phil James (Manager, Integrated Water Management, Credit Valley Conservation)
- David Kellershohn (Manager, Stormwater Management, City of Toronto)
- Brian Kelly (Manager of Sustainability, Durham Region)
- Francois Langevin (AVP, Product Innovation, TD Insurance)
- Kevin Law (Group Manager, Eastern Residential Complex Claims, TD Insurance)
- Patrick Lee (Acting Director, Engineering Services, City of Oshawa)
- Dan Lunardi (Manager of Inspections/Deputy Chief Building Official, City of Windsor)
- Chris Manzon (Senior Manager, Pollution Control/Deputy City Engineer, City of Windsor)
- Marcy McKillop (Environmental Services Engineer, City of London)
- Mark Peacock (Director, Watershed Services, Ganaraska Region Conservation Authority)
- Glen Pleasance (Water Efficiency Coordinator, Durham Region)
- Barbara Robinson (President, Norton Engineering Inc.)
- Chris Rol (Acting Director, Catastrophe Analysis, Insurance Bureau of Canada)
- Dan Sandink (ICLR)
- Shaw Zandi (Business Development, Protective Plumbing Canada)

Extreme Wind Technical Committee:

- Brent Bunting (Simpson Strong-Tie Canada, Ltd.)
- Anita DeVries (Executive Officer, Durham Region Home Builders Association)
- Mike Giles (Chief Building Official, Dufferin County)
- Rachelle Gravel (Building Inspector/Plans Examiner, City of Pickering)
- Brian Kelly (Manager of Sustainability, Durham Region)
- Gregory Kopp (Professor, Civil and Environmental Engineering, Western University)
- Kevin Law (Group Manager, Eastern Residential Complex Claims, TD Insurance)
- Kelly Montgomery (Standards Council of Canada)
- Murray J. Morrison (Vice President, Research, Insurance Institute for Business and Home Safety)
- Glen Pleasance (Water Efficiency Coordinator, Region of Durham)
- David Prevatt (Department of Civil and Coastal Engineering, University of Florida)

- Chris Ramseyer (Associate Professor, Director, Fears Structural Engineering Laboratory, University of Oklahoma)
- Chris Rol (Acting Director, Catastrophe Analysis, Insurance Bureau of Canada)
- Dan Sandink (ICLR)
- John van de Lindt (Professor, George T. Abell Professor in Infrastructure - Civil and Environmental Engineering, Colorado State University)
- Ying Hei Chui (Professor, Department of Civil and Environmental Engineering, University of Alberta)

Extreme Heat Technical Committee:

- Suzanne Bérubé (Sustainable Building Technician, Ville de Victoriaville)
- Cindy Choy (Director, Green Building Coordination Team, Province of Manitoba)
- Paulo Correia (Senior Public Health Inspector, Durham Region)
- Anita DeVries (Executive Officer, Durham Region Home Builders Association)
- Catherine Dubois (Post-Doctoral Fellow, University of Toronto)
- Sophie Guilbault (ICLR)
- Brian Kelly (Manager of Sustainability, Durham Region)
- Josie Porto (Vice President, Ontario Region, Wawanesa Mutual Insurance Company)
- Harshan Radhakrishnan (Practice Advisor, Professional Practice, Standards & Development, Engineers and Geoscientists BC)
- Karina Richters (Supervisor, Environmental Sustainability and Climate Change, City of Windsor)
- Chris Rol (Acting Director, Catastrophe Analysis, Insurance Bureau of Canada)
- Dan Sandink (ICLR)
- Ekaterina Tzekova (Low Carbon Buildings Manager, The Atmospheric Fund)
- Graeme Verhulst (Architect, Waymark Architecture)
- Holly Wacker (ICLR)
- James Woodall (Sustainable Design Specialist, HCMA Architecture)

Introduction

The population of Durham Region is expected to reach 960,000 by 2031, a nearly 50% increase over 2016 population levels.¹ Much of this growth will be accommodated in private, ground-related, single-family homes. Durham Region is also exposed to various natural hazards, including short-duration, high intensity (SDHI) rainfall events, extreme wind and tornadoes, and heat waves, and is expecting that risk associated with natural hazards will increase as a result of changing climate conditions. The Durham Community Climate Adaptation Plan outlined the need to increase the resilience of new home construction to specific extreme weather events. The Plan states (page 35):

The Durham community is about to undergo a building boom. Between 2016 and 2025, there are projected to be 53,000 new housing units built in Durham, plus new industrial, commercial, and institutional buildings. It is projected that these homes and buildings will be subjected to extreme heat and rainfall, violent storms, high winds, and an increased chance of flooding. If new climate resilience standards are not instituted, most of these buildings will be designed and constructed for last century's climate conditions, not the climate that is projected to prevail during their lifespan. This would be a huge lost opportunity to increase the resilience of our buildings. This program proposes to develop separate Durham Climate Resilience Standards for:

- *Low-rise residential buildings (e.g., detached, semidetached, town, and row houses); and*
- *High-rise residential buildings (apartments and condominiums), industrial, commercial, and institutional buildings.*

The Draft Durham Region Climate Resilience Standard for New Houses (the Standard) is aimed at increasing the resilience of low-rise residential buildings to current and future extreme weather conditions. The Standard addresses Ontario Building Code (OBC) Part 9 residential buildings with a focus on increasing resilience for the following hazards:

- SDHI rainfall events and associated basement flooding,
- Extreme wind conditions, and
- Extreme heat conditions.

This Standard is the outcome of a three-phase process that involved the development of an “Initial Draft” Standard that was subject to technical review and refinement, and the formation of three Technical Committees to support development of each of the sections of the Standard (basement flood, wind, heat). Technical Committee review of the Standard was carried out from September to November, 2017. The final draft Standard, presented here is the result of this process. An additional phase will involve engagement of the Durham Region home building industry in further refinement of the guidelines presented in the Standard (Figure 1).

The Standard presents measures that are applied on the private-side of the property line, including measures that relate to buildings/building footprints and private yards/landscaping. The measures compliment existing provincial, conservation authority, and municipal (upper- and lower-tier) requirements related to location, design, construction and inspection of low-rise residential buildings and lots. The Standard does not repeat provincial or municipal requirements that are already in place and serve to reduce risks associated with extreme rain, wind and heat (e.g., anchoring of buildings to foundations, restricting connection of foundation drainage to sanitary sewer systems, protection of homes from riverine flood hazards); rather, the Standard serves to fill gaps in existing building and lot design requirements.

The Standard is organized into three parts, each focused on a priority hazard identified in the Region of Durham’s Community Climate Change Adaptation Plan. These sections are briefly outlined here.

Part A: Basement Flood Protection includes measures that help protect homes from SDHI rainfall events. Risk reduction strategies outlined in this section of the document relate to protecting basements from extreme rainfall flood risk by isolating homes from municipal storm and sanitary sewer systems, directing surface water away from the home with application of appropriate site grading and drainage practices, and reducing the contribution of excess storm and groundwater to municipal wastewater systems.

Part A of the Standard addresses private-side flood risks associated with sanitary and storm sewer backup, overland flooding associated with stormwater, infiltration flooding associated with ground and surface water, sump system failure and flood risks associated with failure of building sewers. Critical building construction and inspection issues identified by Technical Committee members and through ongoing work investigating the occurrence of inflow/infiltration (I/I) in new residential subdivisions in Ontario are also discussed in Part A.

Part B: Extreme Wind/Tornado Protection presents measures meant to “harden” low-rise, wood-frame residential structures to the impacts of extreme wind and tornadoes. Measures presented in Part B focus on roofs and roof framing, wall sheathing and fastening, post base and cap connections, and garage doors. These measures address key vulnerabilities observed in the Canadian and Ontario context, which were identified through field and lab investigations, including vulnerabilities identified during post-tornado damage investigations conducted in Ontario. This section also discusses critical construction and inspection issues that influence vulnerability of wood-frame residential construction to tornado and extreme wind events. The inspection and construction issues discussed in this Part were identified by Technical Committee members and were based on findings from post-tornado damage investigations.

Part C: Extreme Heat Protection presents measures aimed at reducing overheating risk for low-rise residential buildings. Prescriptive measures focused on limiting solar heat gain through windows, window shading, window operability, roofing material reflectance and thermal emittance, and landscaping are presented in the Standard. Measures that have been applied or promoted by organizations and local governments in Canada and internationally to manage overheating risk provided the basis for this section of the Standard. These measures serve to reduce the risk of overheating of individual buildings and/or provide urban heat island (UHI) mitigation benefits. While modelling studies focusing on “archetype” housing types in Durham Region should be conducted to provide a strong basis for envelope and air-tightness measures that may serve to limit overheating risk, a discussion of potential building envelope options is also provided in Part C.

Figure 1: Standard Development Process

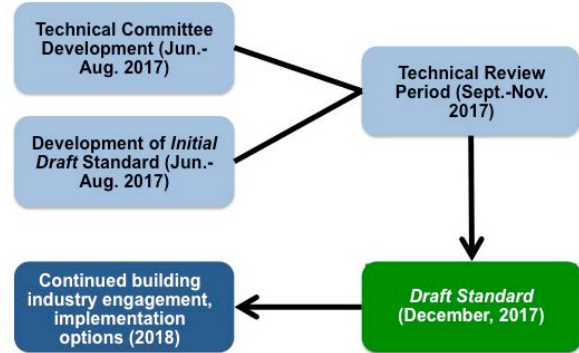

Part A: Basement Flood Protection

Basement flooding is the most significant cause of disaster damages in Canada.² Each year, \$10s if not \$100s of millions of insured and uninsured losses occur as a result of basement flood associated with short-duration, high intensity (SDHI) rainfall events.³ In 2016 alone, 10 individual disaster events caused by SDHI rainfall resulted in over \$25 million in insured losses.⁴ The Greater Toronto Area (GTA) has been affected by numerous extreme rainfall and regional basement flood events in recent years (Table A1). Notably, the July 8, 2013 extreme rainfall/basement flood event remains one of the most expensive disasters in Canadian history. During this event, thousands of homes were flooded and total insured losses were ~\$1.05 billion (2016 CAD).⁵ Roughly 60% of the insured losses experienced during this event were associated with sewer backup into residences.⁶

Aside from damage to property and buildings, basement flooding may result in health risks to occupants associated with introduction of raw sewage, as well as mould growth, allergic reactions, asthma episodes and other respiratory problems.⁷ Homeowners affected by basement flood events are further subject to loss of home livability and stress associated with experiencing the flood event and managing recovery. Vulnerable populations, including those occupying basement apartments, are particularly prone to negative impacts of basement flooding.⁸

The combined planning efforts of the province, conservation authorities and municipalities have significantly limited new development in areas that are prone to riverine flood hazards and hazardous lands adjacent to shorelines. Further, provincial authorities and conservation authorities have developed building requirements for construction proposals in riverine flood hazard areas. Thus, risk reduction measures and building-level flood mitigation practices related to riverine flood are largely addressed by existing arrangements in Ontario and Durham Region and are not further addressed here. The guidelines presented here focus on basement flood hazards associated with SDHI rainfall events that have the potential to overwhelm stormwater management infrastructure and result in basement flooding in non-river flood hazard areas.

It should be further noted that comprehensive basement flood protection requires action on both the private- and municipal-sides of the property line. Municipal-side adjustments that are not covered in these guidelines may

Table A1: Examples of Major, Recent SDHI/Regional Basement Flood Events in the GTA

Event	Notes
Burlington, August, 2014	<ul style="list-style-type: none"> • ~3,000 homes flooded • \$90 million in insured losses • ~200 mm over 8 hrs • ~120 mm in 2 hrs
GTA, July 8, 2013	<ul style="list-style-type: none"> • ~\$1 billion in total insured losses • Total accumulation of 138 mm • 126 mm over 3 hr period
Hamilton, July 22, 2012	<ul style="list-style-type: none"> • 350 reports of flooding in the community of Binbrook, comprised of relatively newly constructed homes (post-2000) • ~60% of flood complaints associated with sewer backup • Up to 250 mm of rainfall recorded over 3 hr period • 4 l/s/ha inflow/infiltration rate (10x design standard)
Toronto, July 15, 2012	<ul style="list-style-type: none"> • Total accumulation of 81 mm
GTA, August 19, 2005	<ul style="list-style-type: none"> • Affected Durham Region municipalities (e.g., Ajax/Laurie Rd.) • \$751 million in total insured losses (2016 CAD) • ~50% of claims associated with residential sewer backup • 153 mm total rainfall in Toronto • 132 mm over a 2 hr period recorded at North York IDF station
Toronto, May, 2000	<ul style="list-style-type: none"> • 102 mm total accumulation • 70 mm over 3 hrs • Affected central Toronto • Design standard for affected areas: ~28 mm over three hours

Sources:

- Amec Foster Wheeler and Credit Valley Conservation. 2017. National Infrastructure and Buildings Climate Change Adaptation State of Play Report. Prepared for the Infrastructure and Buildings Working Group, part of Canada's Climate Change Adaptation Platform.
- Duong, J. 2016. Recovering from the flood: Halton's basement flooding mitigation program. Presentation made to the Institute for Catastrophic Loss Reduction, November, 2016.
- Gainham, C. 2013. The perfect storm: New development, high I/I and a 1000+ year event. Presentation made to the Institute for Catastrophic Loss Reduction, Basement Flood Symposium, September 2013.
- Insurance Bureau of Canada. 2017. Facts of the Property and Casualty Insurance Industry in Canada. Toronto: IBC.
- Kellershohn, D. 2016. Reducing flood risk in Toronto. Presentation to Institute for Catastrophic Loss Reduction, February, 2016.
- Sandink, D. 2007. Sewer backup: Homeowner perceptions and mitigative behaviour in Edmonton and Toronto. Toronto: ICLR.
- T. Bowering, City of Toronto, Jan. 2014

include limiting municipal-side inflow and infiltration (I/I) in public sanitary sewer systems,⁹ defining stormwater overland flow routes and increasing the capacity of municipal/public sewer and stormwater management systems to manage extreme events, among many other options. The scope of these guidelines, however, includes only measures that apply to the private-side of the property line.

Durham Region should also note that, at the time of writing, the Canadian Standards Association (CSA) was developing a national basement flood protection guideline (CSA Z800). An Institute for Catastrophic Loss Reduction (ICLR) staff person was serving as vice-chair of the Z800 Technical Committee. It is strongly recommended that the guidelines presented here be revisited and revised when the final CSA Z800 guideline is published.

Basement Flood Hazards

These guidelines aim to reduce risk from several specific basement flood types, including:

- Sewer backup (storm, sanitary),
- Overland flooding associated with stormwater,
- Infiltration flooding associated with ground and surface water,
- Sump system failure, and
- Flood risks associated with failure of building sewers.

Measures presented in these guidelines serve to protect individual homes from the abovementioned flood hazards, and also serve to reduce basement flood risk at the regional scale (i.e. “sewersheds”) by limiting private-side I/I.¹⁰

It should be generally noted that residential structures should not be expected to withstand forces associated with even relatively minor floodwater depths.¹¹ Therefore, with some exceptions,¹² basement flood protection measures presented in these guidelines focus on keeping stormwater, groundwater/seepage, and sewer backup related floodwaters away from structures, rather than designing structures themselves to become watertight. As discussed above, measures presented here are not meant to reduce risk of damage associated with riverine flood hazards or groundwater hazards that may subject homes and foundations to significant hydrostatic, hydrodynamic and/or buoyancy forces.¹³

New Construction and Basement Flood Risk Reduction

Basement flood protection measures presented in this section rely on the following approaches to limit risk of damage during SDHI rainfall events:

- Isolation from municipal storm and sanitary sewer systems to protect from sewer backflow,
- Directing surface water away from the home with application of appropriate site grading and drainage practices, and
- Reducing the contribution of excess storm and groundwater to municipal wastewater systems.

Figure A1: Sewer Backup Basement Flood Example

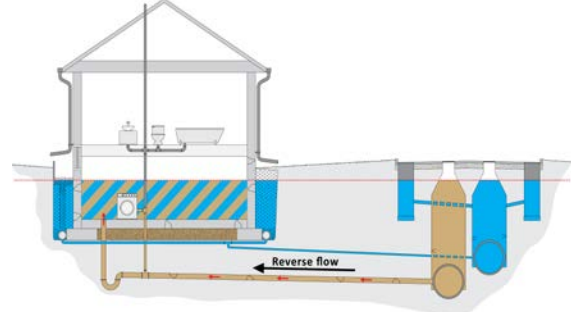

In the simplified example presented here, the sewer systems in a separated sewer area have become overwhelmed resulting in backflow into a home.

Figure A2: Simple Overland/Stormwater Basement Flood Example

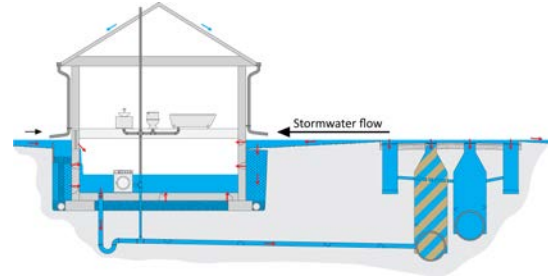

In the simplified example presented here, stormwater flows have exceeded the capacity of stormwater management systems. Water is flowing toward the home via the surface of the lot and entering through above grade openings, including windows and doors.

It should be noted that many of the vulnerabilities that have led to basement flooding and flood risk associated with SDHI rainfall events in existing neighbourhoods have been substantially addressed for new home construction through local and provincial building and site drainage requirements. Key basement flood related factors that have been addressed by existing local and provincial requirements are outlined here. These guidelines are meant to fill the remaining “gaps” in existing requirements for new home construction.

Inflow/Infiltration in New Development

The OBC currently restricts the conduction of storm and sanitary sewage in the same vertical soil or waste pipe, and installation of combined building drains and sewers.¹⁴ Additionally, the OBC specifically restricts connection of foundation drainage to sanitary sewer systems.¹⁵ These provisions serve to significantly limit occurrence of I/I in new subdivisions.

Local by-laws further serve to manage I/I risk in new development. Specifically, the Durham Sewer Use Bylaw states that

no person shall discharge or cause or permit the discharge of stormwater, groundwater, fountain drainage...drainage from private drains or uncontaminated water into land drainage works or connections to any sanitary sewer unless expressly authorized in writing by the Commissioner.¹⁶

Further, Durham Region By-law 41 (2009) states that new foundation drains are not to be connected to sanitary sewers.¹⁷ Technical requirements related to I/I, including restricting foundation drain and downspout connections to sanitary systems, are therefore not further addressed in the guidelines presented here. Inspection and construction factors that increase risk of I/I in new homes, however, are outlined in this document. Recommendations related to sewer laterals that serve to limit infiltration risk are also provided.

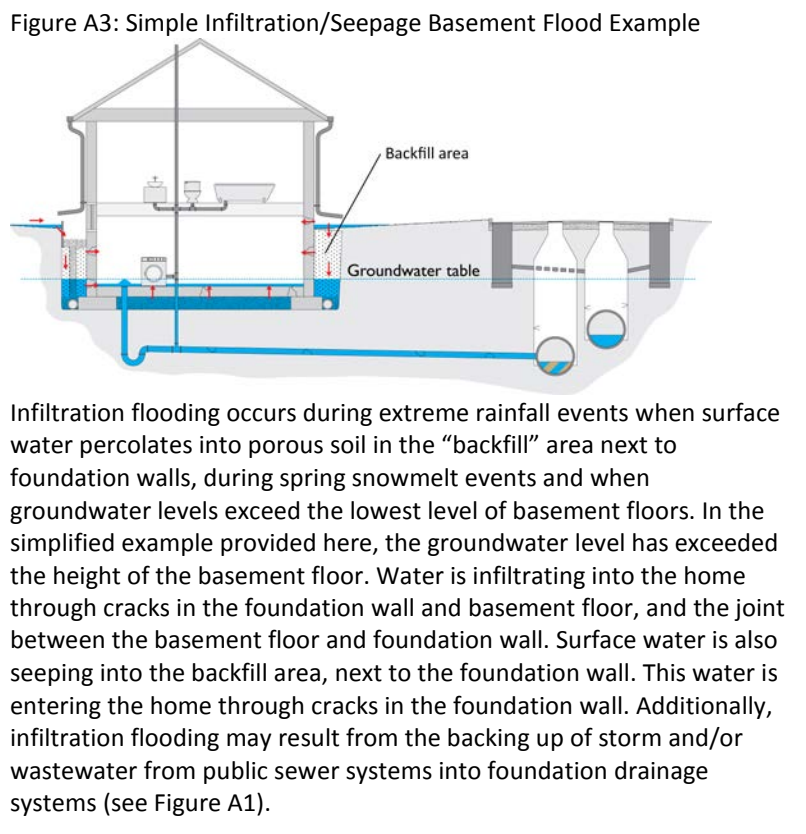

Table A2: Lot grading design criteria, Durham Region lower-tier municipalities

Municipality	Lot-grading standards, requirements
Town of Ajax	Town of Ajax Design Criteria, Section E: Lot Grading
Township of Brock	Township of Brock's Design Criteria and Standard Detail Drawings 1995 sections D and E
Municipality of Clarington	Homeowners’ Guide to Lot Grading and Drainage for Infill Lots, Municipality of Clarington Design Guidelines and Standard Drawings, section 4 Lot Grading Design
City of Oshawa	City of Oshawa, Engineering Design Criteria Manual, Section 5, Lot Grading
City of Pickering	The Corporation of the City of Pickering, Planning & Development Department, Engineering Design Criteria: Lot Grading Plans
Township of Scugog	Township of Scugog Engineering Design Criteria and Standard Detail Drawings, Section E, 2003
Township of Uxbridge	Township of Uxbridge, Design Criteria Section E – Lot Grading, 2016
Town of Whitby	Engineering Design Criteria Section D: Residential Lot Grading and Engineering Design Standards section 300: Grading

Limiting, Sealing Foundation Openings

Dampproofing and waterproofing requirements are provided for in the OBC, including provision of drainage layers,¹⁸ which is not specifically covered by codes in other jurisdictions in Canada.¹⁹ Provisions related to sealing cracks in basement walls and floors that may occur during the construction process, however, are not addressed in the OBC and are therefore addressed in these guidelines. These guidelines further address issues related to foundation penetrations that may exacerbate private-side flood risk.

Site Grading, Drainage and Low Impact Development (LID) Features

The OBC provides general guidance on surface drainage,²⁰ and lot grading design criteria are available in all Durham Region lower-tier municipalities (Table A2). Several lower-tier municipalities have also adopted best practices for controlling extreme rainfall/basement flood risk in new development that exceed typical municipal criteria. These include requirements related to good drainage practices for downspouts and sump pump discharge, including the Township of Scugog, the Town of Whitby, and the City of Oshawa.²¹

A critical issue related to lot grading and drainage that may exacerbate basement flood risk is use of driveways that cause or contribute to surface water collecting near buildings and foundations (e.g., reverse slope driveways). Despite surface drainage requirements identified in the OBC, reverse slope driveways may still be permitted in new home construction in Ontario. For instance, the OBC provides requirements for protection of garages from runoff from a driveway by provision of catch basins to provide adequate drainage.²² GTA municipalities have acknowledged that flood risk is exacerbated by the construction of reverse slope driveways for several decades. Several GTA municipalities have applied measures to restrict or discourage reverse slope driveways,²³ including the City of Pickering and the Township of Uxbridge.²⁴ The guidelines presented here propose expanding restriction of reverse slope driveways to municipalities throughout the entire Region.

Below-grade openings, including below-grade windows, are not a desirable feature from a private-side basement flood protection perspective (see Box A1). It is recognized, however, that window wells, allowing for larger basement windows and basement bedroom emergency egress, are a common element in new home construction. While it is preferable to avoid use of window wells, measures that can be taken to protect window wells from accumulation of precipitation are presented in these guidelines.

While grading of backfill is included in the OBC,²⁵ the National Research Council of Canada has published specific recommendations related to protection of backfill zones from water infiltration, including impervious backfill capping.²⁶ A number of additional details related to lot grading and drainage that are not included in the OBC, including grading and capping of backfill zones, downspout and sump pump drainage and discharge are outlined in the recommendations below.

Box A1: Window Wells

It is recognized that below-grade windows/window wells are a common feature in new home construction and provide several benefits, including larger basement windows and emergency egress. From a lot drainage and flood risk management perspective, however, they are not recommended. As reported by Swinton and Kesik (2005):

Window wells are not a preferred basement construction practice and should be avoided at all costs, as they are lower than grade, they attract snow and surface water, and the good drainage needed to make them work can quickly overload the drain-pipe system below.

Pg. 98 in Swinton, M., and Kesik, T. 2005. Performance Guidelines for Basement Envelope Systems and Materials: Final Research Report. Ottawa: Institute for Research in Construction, National Research Council.

While not directly addressed in the provisions outlined in this document, issues associated with access and maintenance of rear-yard catch basins were discussed by basement flood Technical Committee members. Specifically, rear-yard catch basins may depend on home/property owner maintenance, especially when easements have not been secured to allow municipal access to these drainage features. It was further recognized that failure or blockage of rear-yard catch basins would not normally significantly increase flood risk, as major/overland drainage routes would safely convey stormwater away from homes in new subdivisions. Nevertheless, the Technical Committee agreed that it was important to specify that municipalities must secure easements for rear-yard catch basins, and that rear-yard catch basins must remain accessible for maintenance.²⁷

Technical Committee discussion further outlined the need to balance the use of Low Impact Development (LID) measures and the need for basement flood protection. For example, it was noted that even in new developments, high rates of I/I have been associated with leaking private and municipal-side sanitary infrastructure. In these instances, it is possible that LID features could exacerbate I/I, and therefore increase basement flood risk. The need to ensure that LID features are hydraulically disconnected from basements, structures, and the suite of drainage infrastructure servicing individual homes (e.g., foundation drainage systems) was further highlighted by Technical Committee members, as was the need to ensure that private-side LID measures are properly maintained.

Box A2: Indemnities Registered on Title

Though the City of Toronto’s Zoning By-law restricts installation of reverse slope driveways, a minor variance may be granted in some instances to allow this type of driveway. Because installation of reverse slope driveways and below-grade garages significantly increases flood risk, an indemnity agreement may be added as a condition for approval of the minor variance. The agreement is registered on title to the land, and therefore serves to indemnify the municipality against flood impacts that may result from the installation of the driveway for current and future property owners.*

The Draft Durham Region Climate Resilience Standard for New Houses presented here recommends that reverse slope driveways never be installed; however, municipalities may consider application of an indemnity agreement approach when allowing other types of below-grade entranceways that exacerbate flood risk (e.g. basement stairwells).

*Pers. Comm., David Kellersohn, Manager of Stormwater Management, City of Toronto, Nov. 2017.

Foundation Drainage, Sump Pump and Downspout Discharge and Drainage

Foundation drainage discharge configuration depends on specific site conditions, including slope, proximity to ravines, size of lots and carrying capacity for sump pump discharge, capacity of stormwater systems, existence of foundation drain collector systems, among other factors. It should be noted that preference for a specific foundation drain discharge option is not expressed in the provisions outlined in this document. Nevertheless, for the purposes of illustration and to provide context, a general overview of benefits and drawbacks of three common foundation drainage discharge configurations are presented from a private-side flood mitigation perspective in Table A3.

Foundation drainage requirements are provided for in the OBC.²⁸ A recurring issue that is not directly addressed in the OBC, however, is vulnerability of foundation drain systems to blockages associated with fine soil particles. Further, downspout extensions are required when downspouts are not connected to sewers, however the OBC is not specific about downspout drainage and discharge points.²⁹ Further topics not addressed by the OBC and addressed in these guidelines include sump pump backups, backup power and failure alarms. The issue of icing of private and public walkways, driveways, streets and related infrastructure is further addressed in these guidelines.

Table A3: Comparison of Common Foundation Drainage Options (private-side flood mitigation perspective)

Option	Benefits	Drawbacks
Gravity drainage to storm or foundation drainage collector (FDC) system	<ul style="list-style-type: none"> Reduces reliance on sump, sump pump systems. Does not depend on carrying capacity of lots (based on lot size, soil conditions, slope, etc.). 	<ul style="list-style-type: none"> Protection from backflow requires installation of backwater valve(s). Provisions must be made for foundation drainage discharge in the event of valve closure (e.g., overflow to sump pit/pump, discharge to surface). Sump pump systems require inspection, maintenance and backup power. Foundation drain connections to storm and FDC systems increase load during periods when these systems are stressed (e.g., during extreme rainfall events), increasing risk that water will not effectively drain from foundation drainage systems and increasing risk of backflow.
Drainage to sump, discharge via sump pump to surface of the lot	<ul style="list-style-type: none"> Provides passive hydraulic break from municipal stormwater or FDC system. Provides protection of foundation drainage system from sewer backflow. Does not require installation of storm private drain collector/FDC connection. May serve to attenuate flow of foundation drainage to municipal stormwater systems. 	<ul style="list-style-type: none"> Relies on sump pumps for foundation drainage discharge, which require inspection and maintenance. Power requirements for sump pumps (e.g., increased energy use, energy costs, failure during power outages). Requires backup systems, alarms for sump pumps. Drainage to lots may be limited based on carrying capacity (based on lot size, soil conditions, slope, etc.). Improper discharge practices (e.g., discharging too close to foundation wall, recirculation of foundation discharge) may exacerbate flood hazards, risk of sump pump failure.
Drainage to sump, discharge via sump pump to external downpipe that is connected to storm or FDC system	<ul style="list-style-type: none"> When outlets are installed well above probable hydraulic grade line in FDC or storm sewers, this approach provides passive hydraulic break from municipal stormwater or FDC systems. Provides protection of foundation drainage system from sewer backflow. Does not depend on carrying capacity of lots (based on lot size, soil conditions, slope, etc.) to manage foundation drainage discharge. 	<ul style="list-style-type: none"> Relies on sump pumps for foundation drainage discharge, which require inspection and maintenance. Power requirements for sump pumps (i.e. increased energy use, energy costs, failure during power outages). Failure to appropriately install and protect downpipes and stormwater connections during backfilling may result in disconnection or cracking of pipes, exacerbating flood risk associated with recirculating foundation drainage discharge. A storm or FDC service lateral must be provided, requiring maintenance and exposing the building to potential issues associated with poor construction/installation of laterals.

While OBC 9.14.5.2 permits the use of sump pits with automatic pumps when gravity drainage is not possible, no guidance is provided related to sump pump selection and capacity of sump pumps and pits. Some Canadian municipalities, including Moncton,³⁰ Winnipeg,³¹ and Lethbridge³² have provided specific guidance on sump system/sump pump design and material selection. Specifically, the City of Winnipeg Building By-Law no. 4555/87³³ outlines requirements for sump system design and capacity. Local authorities having jurisdiction may consider developing similar standards to reduce the risk of sump failure associated with inadequate pump and sump capacities.

Municipal wastewater and flood advisory staff in LaSalle, Ontario and Edmonton, Alberta highlighted sump pump drainage issues associated with discharge into storm laterals. Specifically, during the September 2017 extreme rainfall event in LaSalle, Ontario, essentially all basement flood complaints were associated with overwhelmed sump pump systems. Sump pump discharge was conveyed to municipal storm sewers via storm laterals, which were fastened directly to foundations walls (see Figure A4). Cracks in the storm laterals resulted in sump pump discharge draining back into the backfill zone and re-entering the foundation drainage system. This recirculation overwhelmed sump pumps and resulted in basement flooding.³⁴ While this Standard does not prescribe foundation drainage connection and discharge

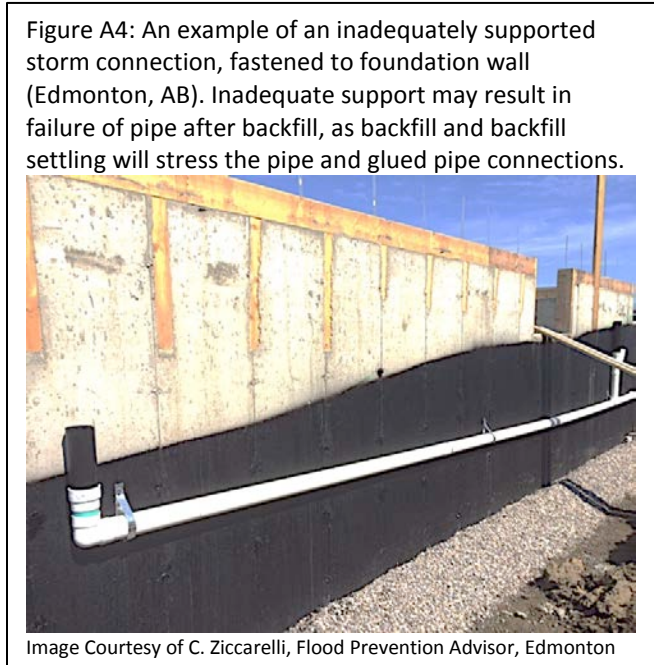

approaches, the issues identified above highlight the need to balance trade-offs between these various discharge options.

Sewer Backflow Protection

Sewer backup is frequently associated with rainfall-derived I/I (RDII) in separated sanitary sewer systems, resulting in surcharging during extreme rainfall events. Because of the intensity of many of the RDII events that result in significant basement flooding events, it is not always possible to identify which areas of a municipality are at high risk until after an event has occurred. Even new subdivisions may experience significant regional sewer backup events during SDHI rainfall events. For example, the community of Binbrook (City of Hamilton) was affected by a severe rainfall event in 2012 resulting in the flooding of approximately 350 homes. Sixty percent of these homes were flooded with sewer backup, despite the fact that the community was comprised largely of new housing, built after the year 2000.³⁵ Further, the August 2005 sewer backup event in Southern Ontario affected a large portion of the City of Toronto that was served by separated sewer systems³⁶ and the City of Mississauga was affected by an extreme rainfall event that resulted in surcharged sanitary sewer systems causing sewer backup, even though the majority of the City is serviced by relatively new, separated sewer systems.³⁷

Protection from sewer backflow is addressed in Article 7.4.6.4 of the OBC. Specifically, sentence 3 of this article states that backflow protection is required “...where a building drain or a branch may be subject to backflow...” Several Ontario municipalities have interpreted this sentence of the OBC in a way that requires sewer backflow protection on all or most new homes, while others apply this sentence to require sewer backflow protection only in special circumstances.³⁸

Specifically, municipalities have adopted an interpretation of the OBC that all new homes that have fixtures “...below the level of the adjoining street...” or “...below the upstream sanitary manhole cover...” are exposed to the risk of sewer backup, and therefore require sewer backflow protection. For example, in 2008 the City of Toronto stated that “...the whole City be declared at risk of basement flooding in the event of unusually severe or extreme precipitation...,” resulting in an interpretation of OBC Sentence 7.4.6.4.(3) in a manner that requires backwater valves in all homes with fixtures below the adjoining street.³⁹ Backwater valves are also required in new home construction in Windsor, Ottawa, Welland, Hamilton, Mississauga, Collingwood, St. Catharines and Niagara Falls, among other communities. The guidelines below recommend adopting an interpretation of OBC 7.4.6.4.(3) that would result in installation of backwater valves in the majority of new homes in Durham’s lower-tier municipalities. These guidelines further set out provisions to

Box A3: Use of Sewage Ejectors in LaSalle, Ontario for Sanitary Backflow Protection

The sanitary sewer system in LaSalle was constructed in the late 1970s. The system consists of gravity mains, with a series of pump/lift stations. Each station has a gravity overflow. From the initial inception, the sanitary sewer hydraulic grade line (HGL) has been estimated throughout the entire system based on the respective sewer segments and the governing down stream pump station based on pump failure scenario. All basement elevations that lie under the respective HGL fronting the respective property are required to install sanitary sewer ejector pumps to establish basement drainage. This HGL is considered when servicing new lots. Sewer connections are always positioned above the HGL, resulting in sanitary connections that are higher than basement floor slabs for many LaSalle homes. Plumbing fixtures located in basements of these homes must therefore be drained to the sanitary connection via sewage ejector systems. In a community with approximately 10,000 homes, roughly 3,500 have sewage ejector systems.

Sanitary sewage ejectors have served to protect homes in LaSalle against sewer backup by allowing for a hydraulic break between municipal and private sanitary systems. For example, it was reported that no homes in LaSalle experienced sanitary sewer backup during the September 2017 extreme rainfall event that affected the Windsor, Ontario area. Basement flooding reported during this event all resulted from overwhelmed sump pumps.

Few, if any, reports of sewage ejector failures have been made to Town staff since these systems were first incorporated into homes in the late 1970s. Nevertheless, the Town is unaware if privately owned sewage ejectors have been appropriately maintained, possibly increasing risk of failure over time.

Personal communication, Peter Marra, Director of Public Works, Town of LaSalle, October, 2017.

ensure that basement flood protection equipment, including backwater valves, remain accessible for the purposes of inspection and maintenance.

Generator Connection Rough-Ins

An additional topic identified as a priority in the Durham Community Climate Adaptation Plan was rough-ins for external generator connections in new homes. Specific requirements for generator connection rough-ins are not outlined in current construction and electrical code requirements. Though considerably more costly than battery backup systems, generators may be considered a preferred option for running sump pumps as well as other key household utilities (e.g., freezers, HVAC) during power outages. The guidelines provide an optional provision for the requirement of rough-ins for generator connections for all new homes in Durham Region.

Construction and Inspection Issues

Recent work focused on southern Ontario municipalities has revealed unacceptably high rates of I/I⁴⁰ in new subdivisions. This work has also revealed limited enforcement of OBC provisions related to support for underground horizontal piping (OBC 7.3.4.6), backfilling of pipe trenches (OBC 7.3.5.1) and provisions related to testing of drainage and venting systems (OBC 7.3.6), which have contributed to I/I in new subdivisions.

Specifically, surveying and in-depth discussion with wastewater and building departments from 20 southern Ontario municipalities indicated that ~90% of surveyed municipalities were not conducting air/water testing for private-side drainage systems in new subdivisions. Inadequate pipe bedding for building sewers, which increases stress on sewer connections and risk of cracking and failed joints, has also been identified as an ongoing issue in southern Ontario. Limited inspection of the pipe joint at the property line (where the building sewer connects to the municipal sanitary sewer stub – see Figure A6) has also been identified,⁴¹ as have lack of installation of test tees at the property line, limiting the opportunity to conduct appropriate water testing of laterals.⁴² While these issues have not been identified in the Region of Durham specifically, the experience of the abovementioned municipalities suggests that special care should be taken to ensure that new construction does not exacerbate I/I issues.

Figure A5: Newly installed building sewer (storm) illustrating poor bedding practices



Source: B. Robinson, Norton Engineering, 2016

Technical Committee input highlighted the importance of exfiltration tests for private-side sanitary sewer connections to ensure new sewer connections are not leaking and contributing to I/I. It was further noted that current OBC requirements for water and air testing, as well as municipal-side standards related to sanitary sewer design and construction (specifically OPSS 410), include provisions related to testing of sanitary infrastructure for leakage. Nevertheless, given the results of recent work in Ontario on I/I in new subdivisions, special attention to the importance of testing of private-side sanitary sewer infrastructure is warranted.

Further, expert reviewers indicated that “exterior” water management and drainage systems/connections are often not inspected. Specifically, inspectors should ensure:⁴³

- Inspection of foundation drain connections to FDC systems (where provided),
- Inspection of downpipes to foundation drain collectors/storm sewer systems, and
- Inspection of roof leader connections to storm sewer systems.

Figure A6: Public- and Private-Side Construction Errors Leading to High I/I Rates in New Subdivisions⁴⁴

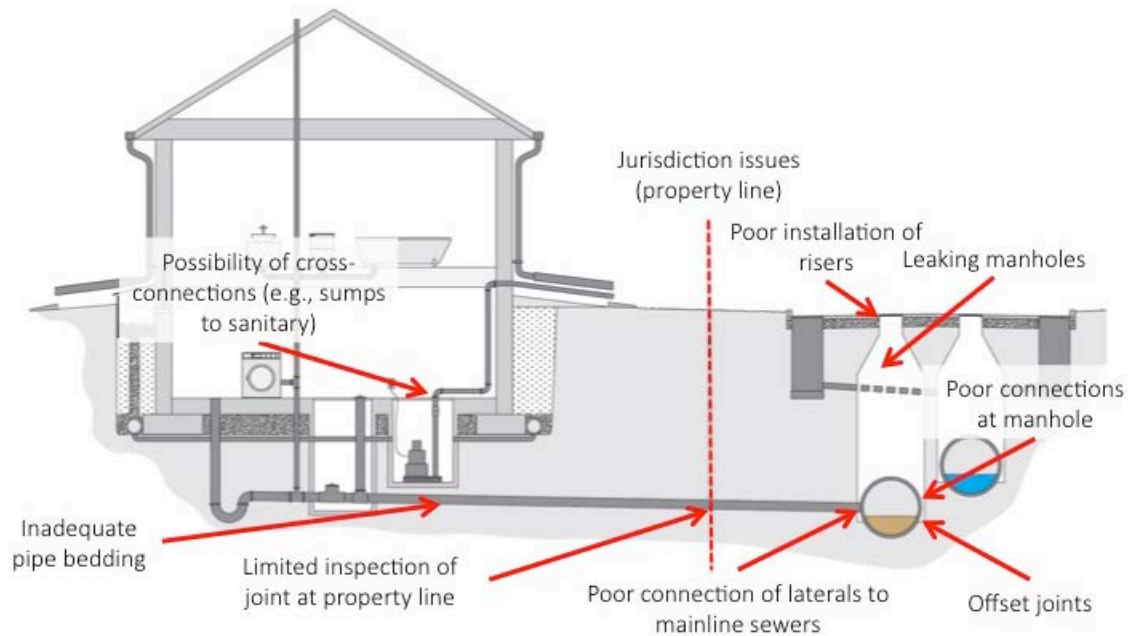

Basement Flood Protection Measures

Basement flood protection measures presented here are considered as either “primary” or “enhanced” measures. Measures identified as “primary” by the Technical Committee were considered to have significant implications for basement flood risk and/or I/I on the private-side, and/or should be considered for implementation in all new homes. Enhanced protection measures include measures that would assist in reducing basement flood risk, but may not necessarily be appropriate in all circumstances (i.e. may be considered redundant, technically complex, and/or expensive).

Several of the recommendations contain multiple sub-recommendations (e.g., Recommendation 1. a, b and c). Use of the word “or” indicates that any one of the sub-parts may be adopted to satisfy the recommendation. Use of the word “and” indicates that multiple sub-parts should be adopted to satisfy the recommendation.

Basement Flood Protection Measures (Primary)

Site Grading and Drainage			
#	Recommendation	Purpose	Notes
1.	<p>a) The top layer of backfill (i.e. backfill capping) should be made to be impervious to surface water.</p> <p><i>And</i></p> <p>b) Impervious backfill capping should extend beyond the line of excavation and backfill.⁴⁵</p> <p><i>And</i></p> <p>c) Impervious backfill capping should be made to slope away from the building after settling of backfill.</p>	<ul style="list-style-type: none"> • Permeable, poorly graded (settled) backfill zones increase risk of pooling of surface water near the foundation wall. • Pooling of water near the foundation wall and seepage of surface water into backfill zone can increase infiltration flood risk and increase load on foundation drainage systems. 	<ul style="list-style-type: none"> • OBC 9.12.3.2. Grading of Backfill (1) Backfill shall be graded to prevent drainage towards the foundation after settling. • Backfill capping and extending of backfill capping beyond the line of excavation and backfill is not covered in OBC. • Backfill capping options may include:⁴⁶ <ul style="list-style-type: none"> ○ Use of a fine-grained, low-permeability cohesive soil (e.g., clay), sloped away from the foundation wall, or ○ A membrane or low-permeability insulation board placed just below ground, sloped away from the foundation wall. ○ Other measures may be considered based on site conditions. • Impervious cover must be made to slope away from the building after backfill has settled. Impervious cover that slopes toward the building would serve to intensify basement flood risk. • Reducing load on foundation drainage system is particularly important when foundation drainage is directed to sump pits and discharged via sump pumps. • The intention of the impervious backfill cover is to direct surface water away from the backfill zone; the impermeable layer should fully protect the backfill area. This may require extending the impermeable cover slightly beyond the backfill zone (see Figure A7).
2.	<p>Driveways that are likely to cause or contribute to runoff water entering or accumulating near or against a garage, building, and/or foundation should not be installed.</p>	<ul style="list-style-type: none"> • During extreme rainfall events, reverse slope driveways direct water into buildings. • Reverse slope driveways increase the risk of regional basement flooding by increasing inflow into sanitary sewer systems. Specifically, water that is directed into buildings via reverse slope driveways may enter the municipal sanitary sewer systems through basement floor drains. • Drains and/or catch basins located at the bottoms of reverse slope driveways that are connected by gravity to sewer systems increase exposure to flooding associated with backing up/surcharge of these systems. 	<ul style="list-style-type: none"> • Reverse slope driveways were found to be a contributor to flood risk and impact during recent extreme rainfall related flood events in GTA municipalities.⁴⁷ • Reverse slope driveways are prohibited or discouraged in new construction in several Ontario municipalities, including Toronto, Markham, Hamilton and Vaughan.⁴⁸ • Reverse slope driveways have been restricted through use of lot grading and drainage requirements (e.g., Cities of Pickering and Hamilton) and zoning requirements (e.g., Cities of Markham, Vaughan, and Toronto).⁴⁹

Figure A7: Examples of impermeable capping for backfill zones. Example (a) illustrates use of clay cap, example (b) illustrates use of pavers.⁵⁰

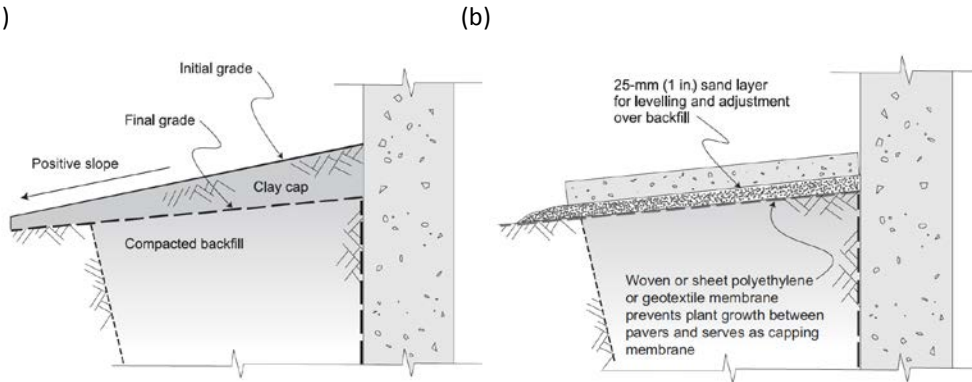

#	Recommendation	Purpose	Notes
3.	<p>a) Exterior basement stairwells should not be installed in new houses.</p> <p><i>Or</i></p> <p>b) Alternatively, where basement stairwells are deemed unavoidable:</p> <p>i) They should be protected against locally accepted hazard levels for major drainage systems.</p> <p><i>And</i></p> <p>ii) Drains/catch basins located at the bottom of the stairwell should not directly or indirectly connect to municipal storm, sanitary or FDC systems.</p>	<ul style="list-style-type: none"> Exterior basement stairwells are not considered good site grading and drainage practice, as they create exposure to overland flow risk by creating a path to convey surface water directly into buildings. Below-grade entranceways increase sanitary sewer inflow risk, as water that enters basements via basement stairwells may enter sanitary sewers via basement floor drains, contributing to regional sanitary sewer backup risk. Stairwell drains/catch basins increase exposure of buildings to backflow from storm or sanitary sewer systems when directly connected to these systems. 	<ul style="list-style-type: none"> A lot grading and drainage issue, similar to reverse slope driveways. Residential building entryways should be located above-grade wherever possible. <p>When basement stairwells are used:</p> <ul style="list-style-type: none"> They must be protected against overland flows associated with locally defined risk tolerances (e.g., 1 in 100 year return period stormwater overland flow events, or hazard levels specified by local authority having jurisdiction). Drains located at the bottom of the stairwells should not connect to municipal storm, sanitary or FDC systems. This provision is meant to protect the municipal systems from inflow of stormwater and to protect the building from sewer backflow into the basement stairwell drain.

#	Recommendation	Purpose	Notes
4.	<p>a) Avoid use of window wells wherever possible⁵¹</p> <p><i>Or</i></p> <p>b) Alternatively, where window wells are deemed unavoidable, window wells should be protected against locally accepted hazard levels for major drainage systems.</p>	<ul style="list-style-type: none"> Window wells increase exposure to negative impacts of high intensity rainfall events because they are lower than grade, increase the exposure of basements to drainage issues associated with accumulation of snow and surface water, and window well drainage practices increase load on foundation drainage systems.⁵² Though it is generally preferred to restrict the use of window wells in new home construction, measures may be applied to protect below-grade windows and window wells where they are deemed necessary. 	<ul style="list-style-type: none"> From a flood risk management perspective, below-grade windows should be avoided. It is recognized, however, that window wells are a common feature in new residential building construction and restriction of their use may be considered impractical in many instances. <p>When window wells are used:</p> <ul style="list-style-type: none"> They must be protected against overland flows associated with locally defined risk tolerances (e.g., 1 in 100 year return period stormwater overland flow events, or hazard levels specified by local authority having jurisdiction). National Research Council Construction Technology Update #69⁵³ provides additional guidance on protection of window wells from accumulation of precipitation and overland water. Window well covers may be applied to reduce water accumulation in the window well. Application of window well covers should respect exit/egress requirements stipulated in the OBC.⁵⁴

Limiting Risk of Water Entry through Foundation Penetrations and Openings			
#	Recommendation	Purpose	Notes
5.	<p>a) All utility penetrations should be located above-grade.</p> <p><i>And</i></p> <p>b) Identify and seal potential overland flood entry points, including openings that are at grade or close-to-grade.</p>	<ul style="list-style-type: none"> Reduce risk of entrance of surface water into basement in the event that water accumulates close to the building and foundation wall. 	<ul style="list-style-type: none"> Site grading and drainage should be applied as the primary means to reduce the risk of water accumulating near foundation walls; however, openings increase likelihood that water will enter the building if water accumulates near foundation walls. Overland, infiltration flood entry points may include: <ul style="list-style-type: none"> Gaps between foundation walls and framing around windows and doors, Gaps around piping, wiring and conduit penetration in foundation walls, and Other openings as identified. Requirements set out by the local authority having jurisdiction, relevant code requirements (including but not limited to electrical codes, the requirements of local electrical utilities) must be adhered to.⁵⁵

Foundation Drainage and Foundation Drainage Discharge			
#	Recommendation	Purpose	Notes
6.	Incorporate means of accessing foundation drainage systems to facilitate inspection and maintenance (e.g., access and cleaning chimneys).	<ul style="list-style-type: none"> • Foundation drainage systems are prone to blockage with fine soil particles over their lifecycles. • The cost of replacing and repairing foundation drainage systems is extremely high, necessitating measures to limit risk of blockage and failure over the lifecycle of the system. • Providing access to these systems will allow for inspection and increases viability of maintenance over their lifecycles. 	<ul style="list-style-type: none"> • Provision of access to foundation drainage systems to allow inspection and maintenance to extend the useful life of foundation drainage systems. • Maintenance (e.g., flushing) often requires excavation of key locations around foundation wall to access foundation drainage system and to remove flushed debris. Excavation adds to the cost and complexity of maintaining foundation drainage systems. • The alternative to maintenance – removal/replacement of foundation drainage systems – is extremely expensive (likely \$10s of thousands for an average existing residential building). • Potential options that may be considered to achieve this provision include: <ul style="list-style-type: none"> ○ Provision of “access and cleaning chimneys” as per BNQ 3661-500/2012⁵⁶ ○ Alternative means of increasing accessibility of foundation drainage systems as appropriate and approved by the authority having jurisdiction. • Application of methods to reduce the service requirement of foundation drainage systems, including use of materials that are less likely to become blocked, is also encouraged. For example, smooth-walled, rigid, perforated PVC pipe may be considered less vulnerable to blockage, when compared to ringed, flexible pipe that is commonly used for foundation drainage applications.⁵⁷ Rigid, smooth walled pipes may also increase ease of access for closed circuit television (CCTV) inspections.

#	Recommendation	Purpose	Notes
7.	Protect foundation drainage systems from sewer backflow.	<ul style="list-style-type: none"> • Protect foundation drainage from sewer backflow in the event of SDHI rainfall events, surcharge of stormwater systems. • Applies to instances where foundation drainage systems are drained by gravity to storm private drain connections or foundation drain collector systems. 	<ul style="list-style-type: none"> • OBC 7.4.6.4 Protection from Backflow might be considered applicable only when foundation drainage systems (subsoil drainage pipes) are connected to sanitary sewer systems. • At the time of writing, an OBC code change request to clarify application of OBC 7.4.6.4 to both storm and sanitary connections was under consideration.⁵⁸ • Local municipalities in Durham Region provide strict design guidance for protection of foundation drainage systems from backflow. For example, City of Oshawa requires that “the underside of the footing elevation shall be designed such that it is located at minimum 0.60 metres above the 100-year hydraulic grade line elevation at the point of the foundation drain connection to the storm sewer” (for type II systems connected to storm sewers).⁵⁹ • Provision of private-side backflow protection provides an additional safety factor, given potential changes in frequency/intensity of SDHI rainfall events under changing climate conditions and watershed changes/urban development over time. • Note that the City of Ottawa has required backwater valves on storm connections since 2004.⁶⁰ • For gravity-drained systems, backflow protection is typically provided through provision of backwater valves. If this approach is used, provision should be made for foundation drainage discharge in the event that storm system surcharge closes the backwater valve (i.e. sump pit/pump systems draining to the surface of the lot). • Backwater valves must comply with OBC provisions. Further, the following standards may be consulted when selecting storm and sanitary backwater valves: <ul style="list-style-type: none"> ○ ASME A112.14.1-2003 – Backwater Valves.⁶¹ ○ ANSI/CAN/UL/ULC 1201:2016 – Sensor Operated Backwater Prevention Systems.⁶² ○ CAN/CSA B1800-15 – Thermoplastic non-pressure piping compendium⁶³
8.	Devices and technologies used to protect foundation drainage systems against sewer backflow must remain accessible for routine maintenance and inspection.	<ul style="list-style-type: none"> • Mechanical devices typically used to protect residential buildings against sewer backflow (e.g., backwater valves) require routine inspection and maintenance to remain effective over their lifecycle. • These devices should never be made inaccessible by being placed under flooring materials, basement floor slabs, behind walls, etc. 	<ul style="list-style-type: none"> • This provision applies specifically to gravity drained foundation drainage systems protected from backflow by use of backwater valves.

#	Recommendation	Purpose	Notes
9.	<p>Sump pump systems should be supplied with:</p> <p>a) A backup sump pump with backup power supply, set to engage in the event of a power outage or mechanical failure of the primary pump.</p> <p><i>And</i></p> <p>b) A failure alarm to notify homeowners that the primary pump has failed.</p>	<ul style="list-style-type: none"> • Sump pump failure is a major cause of flood damage during extreme rainfall/urban flood events. • Backup power/pumps help to address flood risk associated with sump failure due to mechanical failure and power supply interruption. • Alarms provide notification to homeowners that the primary pump has failed, and that action should be taken to ensure that there is not prolonged reliance on secondary/backup pumps. 	<ul style="list-style-type: none"> • Backup power for sump pumps is not covered by the OBC. • Pump failure alarms are not covered by the OBC. • Sump systems should be serviced by a primary (electric) sump pump, a backup pump provided with backup power and an alarm system to notify occupant of failure of primary pump. • The secondary pump float should be set to engage pump at higher water level than the primary pump. • The failure alarm should be set to engage when the primary pump fails. • Alarm systems may be provided as part of backup power systems. • Generators may also be used as backup power systems for sumps. • Due to installation, water use, and potable water backflow concerns, it is recommended that water powered backup pumps not be used.⁶⁴
10.	<p>Sump pump discharge pipes should be supplied with a check valve near the discharge pipe connection to the sump pump.</p>	<ul style="list-style-type: none"> • Prevents reversal of flow of water through discharge pipe, reducing risk of overloading, burn-out of sump pumps. 	<ul style="list-style-type: none"> • Check valves for sump pump systems handling foundation drainage are not required by the OBC. • Reversal of flow of water through discharge pipes results in exertion of additional load on sump pump, increasing the risk of burnout/failure. • Check valves should be located in discharge pipes as close to the pump as possible.

Downspout Discharge and Drainage			
#	Recommendation	Purpose	Notes
11.	<p>a) When downspouts drain over the surface, discharge points:</p> <p>i) Should be located at least 1.8 m away from foundation walls.</p> <p><i>And</i></p> <p>ii) Should drain to a permeable surface.</p> <p><i>And</i></p> <p>iii) Should be provided with a splash pad.</p> <p><i>Or</i></p> <p>b) Alternatively, downspouts should drain to other appropriate conveyance infrastructure or discharge points, as approved by the municipality (e.g., for Roof Drain Collectors, LID/Green Infrastructure, etc.).</p>	<ul style="list-style-type: none"> • Applies when downspouts are made to drain over the surface of lots. • Limits the potential for flood damage due to improper downspout drainage. • Limits potential for negative impacts on neighbouring properties. • Helps ensure that downspout discharge is not entering the building’s backfill zone, leading to excess loads on foundation drainage systems and sump pumps. • Splash pads reduce erosion at downspout discharge points. • Draining over permeable surfaces helps to mitigate/attenuate downspout discharge to municipal stormwater management systems. 	<ul style="list-style-type: none"> • OBC 9.26.18.2. Downspouts states “where downspouts are provided and are not connected to a sewer, extensions shall be provided to carry rainwater away from the <i>building</i> in a manner that will prevent <i>soil erosion</i>” but does not provide specific criteria on discharge and drainage. • Downspout extensions should have a grade of at least 30 degrees, relative to the surface of the ground.⁶⁵ • Where site/drainage conditions do not permit 1.8 m extensions, at minimum ensure that discharge points beyond the line of excavation and backfill (i.e. capped backfill area – see Recommendation #1). • To limit risk of icing, downspouts should not be made to drain over impermeable surfaces, including sidewalks, walkways, driveways, sidewalks, roadways, etc. • The cities of Moncton and Edmonton prescribe requirements for discharge points of eavestrough downspouts (e.g., eavestroughs may be required to discharge at a specific distance from the property line).⁶⁶ • Caution should be applied when draining downspouts into rain barrels.⁶⁷ • Selection, design and construction of appropriate lot-scale/private-side LID features will depend on lot-level factors related to soil, slope, availability of drainage outlets, expected discharge rates from downspouts, etc. See: Sustainable Technologies Evaluation Program (STEP). 2018. <i>Low Impact Development Stormwater Management Planning and Design Guide</i> for appropriate lot-scale/private-side LID features that may be used to manage downspout drainage.⁶⁸ • Provision should be made to ensure that downspout discharge is safely conveyed away from buildings/properties in the event of LID system failure.

Protection from Sanitary Sewer Backflow			
#	Recommendation	Purpose	Notes
12.	All residential buildings served by public sanitary sewers that have fixtures below the adjoining street and/or below the upstream sanitary manhole cover should be protected against sanitary sewer backflow (e.g., backwater valve(s)).	<ul style="list-style-type: none"> Protection from sewer backflow is a critical aspect of basement flood risk reduction. New subdivisions may be at risk of sewer backflow under extreme rainfall conditions. Provision of backflow protection in new construction is significantly less expensive than retrofitting backwater valves/sewer backflow protection. 	<ul style="list-style-type: none"> OBC 7.4.6.4. Protection from Backflow. Sentence 3 states “...where a <i>building drain</i> or a <i>branch</i> may be subject to <i>backflow</i> (a) a <i>backwater valve</i> shall be installed on every <i>fixture drain</i> connected to it when the <i>fixture</i> is located below the level of the adjoining street, or (b) a <i>backwater valve</i> shall be installed to protect <i>fixtures</i> which are below the upstream sanitary manhole cover when a <i>residential building</i> is served by a public <i>sanitary sewer</i>.” Windsor, Toronto, Ottawa, Welland, Hamilton, Mississauga, Collingwood, St. Catharines, Niagara Falls, and other S. Ontario municipalities interpret the above code wording in a manner that results in a requirement for sanitary sewer backflow protection for new houses. Note that OBC 7.1.4.2.(2) states that “where gravity drainage to a sanitary drainage system is not possible, the floor drain required by Sentence (1) may be connected to a storm drainage system, dry well or drainage ditch provided it is located where it can receive only clear water waste or storm sewage.” Floor drains connected to storm connections should also be provided with sewer backflow protection. Backflow protection devices must comply with provisions in the OBC. Further, the following standards may be consulted when selecting storm and sanitary backwater valves: <ul style="list-style-type: none"> ASME A112.14.1-2003 – Backwater Valves.⁶⁹ ANSI/CAN/UL/ULC 1201:2016 – Sensor Operated Backwater Prevention Systems.⁷⁰ CAN/CSA B1800-15 – Thermoplastic non-pressure piping compendium⁷¹
13.	Devices and technologies used to protect against sanitary sewer backflow must remain accessible for routine maintenance and inspection.	<ul style="list-style-type: none"> Mechanical devices typically used to protect residential buildings against sanitary sewer backflow (e.g., backwater valves) require routine inspection and maintenance to remain effective over their lifecycle. 	<ul style="list-style-type: none"> Backwater valves and other backflow protection devices and technologies must remain accessible for routine inspection and maintenance. For example, backwater valves should not be covered by flooring materials, buried beneath basement floor slabs, etc.

Protection from Flooding Associated with Infrastructure Trenches			
#	Recommendation	Purpose	Notes
14.	Incorporate means to protect against reversal of water flow through infrastructure (pipe) trenches.	<ul style="list-style-type: none"> Reduce risk of water backing up through clear-stone gravel bedding material in pipe trenches and entering basements via infiltration/seepage flooding, and overwhelming foundation drainage systems. 	<ul style="list-style-type: none"> Flood hazards associated with water flow through infrastructure (pipe) trenches during flood events considered particularly high if pipes are bedded with clear stone gravel, as this type of bedding contains many voids and readily conveys water. Compliance with this recommendation may include: <ul style="list-style-type: none"> Application of alternative bedding material that does not convey water as readily as clear stone bedding for sewer connection trenches on the private-side of the property line. This material may include Granular A or B. <p><i>And</i></p> <ul style="list-style-type: none"> Incorporation of a clay seal in the pipe trench on the private-side of the property line to reduce the risk of water backing up through utility trenches. See: Clay Seal for Pipe Trenches, OPSD 802.095.

Information to be Provided to Homeowners			
#	Recommendation	Purpose	Notes
15.	<p>a) Homeowners should be notified of the existence of, and maintenance requirements for basement flood protection equipment.</p> <p><i>And</i></p> <p>b) Detailed floor plans/drawings that indicate the location of basement flood protection equipment should be provided to homebuyers.</p> <p><i>And</i></p> <p>c) Basement flood protection equipment should be clearly labeled to allow for identification by homeowners.</p>	<ul style="list-style-type: none"> Basement flood protection equipment, including backwater valves, sump pumps, sump pump power backup systems, etc. require ongoing, routine maintenance to remain effective. A recurring issue identified by post-flood investigations is difficulty locating flood protection equipment, notably backwater valves, when placed in unexpected locations (e.g., in the middle of basement floors, rather than near foundation walls facing public streets). Identifying location of backwater valves and basement flood protection equipment is critical when applying certain drainage systems/sewer connection maintenance practices. For example, auguring inside of backwater valves can permanently damage backwater valves. It is important that contractors and those responsible for maintenance of sewer connections are aware of the location of valves to minimize risk of damage to valves associated with sewer connection maintenance/repair activities. 	<ul style="list-style-type: none"> Provide manufacturer’s recommended maintenance requirements for basement flood protection equipment and/or generate comprehensive guidance document(s) covering maintenance and care of flood protection technologies. OBC Sentence 9.25.3.3. (16) requires that “sump pit covers shall be sealed to maintain continuity of the <i>air barrier system</i>.” Sealing of sump systems may reduce likelihood that systems will be monitored and maintained by residents. Special care should be taken to inform occupants of sump pump maintenance requirements, including safe removal and replacement of sump pump covers. Guidance should be provided for any system of the building that requires maintenance for effective operation, including: <ul style="list-style-type: none"> Foundation drainage systems, Sump pump systems, Rain barrels (if provided), LID/Green Infrastructure (if provided), and Other systems as necessary. Provide homeowners with basement floor plans identifying location of critical basement flood protection equipment, including: <ul style="list-style-type: none"> Sewer cleanouts, Sump pits, Backwater valves (storm and/or sanitary), Other equipment as necessary. Labeling should be provided for basement flood protection equipment to facilitate easy identification of: <ul style="list-style-type: none"> Backwater valves (storm and/or sanitary), Check valves (e.g., on sump pump discharge lines), Sump pits, Primary sump pumps, Backup sump pump(s), Sump pump backup power supply, Sump pump discharge lines, and Other equipment as necessary. Information on sump pump replacement schedule(s) should be provided to homeowners.

Overland/stormwater and groundwater flood hazards			
#	Recommendation	Purpose	Notes
16.	Houses should not be located in areas where there is a known or potential occurrence of overland flood/stormwater hazards.	<ul style="list-style-type: none"> Reduces risk of overland flooding. Part 9 residential buildings should not be assumed to be able to withstand hydrostatic pressure, buoyancy forces associated with groundwater or overland flooding, unless they have been specifically designed for this purpose. 	<ul style="list-style-type: none"> OBC 9.14.6.1. Surface Drainage sentence (1) states that “the <i>building</i> shall be located or the <i>building</i> site graded so that water will not accumulate at or near the <i>building</i> and will not adversely affect adjacent properties.” This sentence does not necessarily address basement flood risk associated with stormwater associated with SDHI rainfall events. The Ontario Provincial Policy Statement 3.1.1 states that “development shall generally be directed to areas outside of... hazardous lands adjacent to river, stream and small inland lake systems which are impacted by flooding hazards,” which does not specifically address basement flood risks associated with stormwater. In the majority of cases, this recommendation will be considered redundant as new subdivisions are designed with well-defined major (overland) stormwater drainage systems that convey surface water away from buildings and lots.⁷²
17.	Foundation drainage systems should not be relied upon to prevent groundwater flooding associated with continually or periodically high groundwater levels.	<ul style="list-style-type: none"> Continual reliance of sump pumps in high groundwater areas increases risk of basement flooding associated with sump pump failure and/or overwhelming of sump pump systems. Groundwater related infiltration flood issues are extremely difficult to manage post-construction. Part 9 residential buildings should not be assumed to be able to withstand hydrostatic pressure, buoyancy forces associated with groundwater or overland flooding, unless they have been specifically designed for these purposes. 	<ul style="list-style-type: none"> The recommendation applies for constant and/or seasonally high groundwater levels. OBC 9.14.6.1. Surface Drainage sentence (1) states that “the <i>building</i> shall be located or the <i>building</i> site graded so that water will not accumulate at or near the <i>building</i> and will not adversely affect adjacent properties.” This sentence does not necessarily address basement flood risk associated with groundwater. The Ontario Provincial Policy Statement 3.1.1 states that “development shall generally be directed to areas outside of... hazardous lands adjacent to river, stream and small inland lake systems which are impacted by flooding hazards,” which does not specifically address basement flood risks associated with groundwater. The Stormwater Planning and Design Manual (MOE, 2003) includes a provision that basement floor elevations be set above groundwater levels.⁷³ Basement flood elevations should be located above continually or periodically (seasonally) high groundwater levels. Sites exposed to continually or periodically high groundwater levels may be considered unsuitable for basement construction.

Basement Flood Protection Measures (Enhanced)

Enhanced Protection			
#	Recommendation	Purpose	Notes
18.	Provide rough-ins to allow for installation of external generators/auxiliary power supply at a later date by homeowners.	<ul style="list-style-type: none"> Generators provide power for key home utilities (e.g., fridges, freezers, HVAC, sump pumps) during power outages. Rough-ins will serve to reduce the cost of installation of generators at a later date. 	<ul style="list-style-type: none"> Generator rough-ins not required by OBC. Generator rough-ins are meant to reduce the cost to homeowners associated with the installation of generators at a later date.
19.	<p>When sump pumps are used to discharge foundation drainage to the surface of the lot:</p> <p>Sump pump discharge should be directed to appropriate drainage infrastructure and should drain at a sufficient distance from foundation walls to reduce risk of foundation drain discharge recycling.</p>	<ul style="list-style-type: none"> Applies when sump pumps are used to discharge foundation drainage to the surface of the lot. When sump pump discharge points are too close to foundation walls, there is increased risk of water recycling into the foundation drainage system (i.e. water that has been pumped percolates into foundation drainage via backfill zone). Drainage to appropriate infrastructure reduces municipal and private sidewalk, walkway, driveway etc. icing risk. Reduces the likelihood that sump pump discharge will negatively affect neighbouring properties. 	<ul style="list-style-type: none"> Sump pump discharge and drainage not covered by the OBC. Sump pump discharge should be directed to drainage swales or other conveyance infrastructure or discharge points, as approved by the local municipality. Sump pump should be made to discharge to permeable surface (e.g., lawns)⁷⁴ or other approved discharge and conveyance infrastructure (e.g., green infrastructure, LID). Where possible, extend sump pump discharge points to minimum 1.8 m from foundation walls. Where site/drainage conditions do not permit 1.8 m extensions, ensure that discharge points are beyond the line of excavation and backfill. Municipalities in Durham Region may assess sump pump discharge as part of lot grading approvals. Selection, design and construction of appropriate lot-scale/private-side LID features will depend on lot-level factors related to soil, slope, availability of drainage outlets, expected discharge rates from sump pumps, etc. See: Sustainable Technologies Evaluation Program (STEP). 2018. <i>Low Impact Development Stormwater Management Planning and Design Guide</i> for appropriate lot-scale/private-side LID features that may be used to manage sump pump discharge drainage.⁷⁵ Provision should be made to ensure that sump pump discharge is safely conveyed away from buildings/properties in the event of LID system failure.
20.	When sump pump discharge pipes are located outside of foundation walls, they should be protected from freezing.	<ul style="list-style-type: none"> Frozen exterior sump pump discharge pipes increase the risk of sump pump failure (burn out of pump) and flood risk, as water will not be able to be discharged from the sump pit. Risk of pump failure/burn out resulting from deadheading caused by build up of ice in discharge lines. 	<ul style="list-style-type: none"> Protection of sump pump discharge pipes from freezing and frost not covered by OBC. The potential for sump pump discharge line freezing has been recognized in Alberta flood protection guidelines.⁷⁶ Properly drained outlets are typically not vulnerable to freeze.

#	Recommendation	Purpose	Notes
21.	Pipe used for private-side sewer laterals (building sewers outside of building) should be gasketed.	<ul style="list-style-type: none"> • Cracking and loose joints increase risk of private-side infiltration into public sanitary sewer systems and increases risk of root blockages over the lifecycle of the sewer connection. • When improperly bedded and backfilled, glued joints have been identified as being vulnerable to cracking and failure in new subdivisions, increasing potential for infiltration into sanitary systems, and increasing risk of lateral failure over the expected lifespan of the lateral. 	<ul style="list-style-type: none"> • Gasketed pipe is typically used for municipal sanitary sewer stubs. This recommendation would result in application of gasketed pipe for building sewers on the private-side of the property line. • Gasketed pipe should conform to existing OBC requirements and referenced standards related to building sewers/plastic pipe and fitting used underground (see OBC 7.2.5.10). • Testing of lateral connections is critical to ensure proper performance, including limiting risk of infiltration/exfiltration (see OBC 7.3.6). • While properly installed solvent cement joints perform well for private-side sanitary lateral applications, recent work in Southern Ontario has indicated that required installation procedures are often not adhered to. A survey of municipal officials related to high rates of I/I in new subdivisions has suggested limited application of testing requirements, and improper bedding and backfilling practices, leading to increased risk of I/I associated with private-side sanitary laterals.⁷⁷
22.	Foundation walls and basement floor slabs should not allow water penetration/water leakage. ⁷⁸	<ul style="list-style-type: none"> • Cracks in foundation walls and basement floors that have the potential to result in water leakage/penetration should be sealed. • Cracked basement walls and floors increase risk of infiltration flooding. 	<ul style="list-style-type: none"> • Aside from existing dampproofing and waterproofing requirements (OBC 9.13.2, OBC 9.13.3), the OBC provides no specific requirement to seal cracks that may occur during the construction process. • Cracks in foundation walls and basement floors may occur during or shortly after construction process (associated with operation of heavy equipment near completed buildings, curing of concrete, etc.), or after construction with settlement. • Provision of drainage layers will limit likelihood that water will enter basements through cracks. • Sealing cracks from the inside or outside of the foundation wall provides an additional level of protection. • This recommendation applies to:⁷⁹ <ul style="list-style-type: none"> ○ Cracks in concrete basement floors that exceed 4 mm in width, ○ Cracks in concrete block foundation walls exceeding 2 mm in width, ○ Cracks in cast-in-place concrete foundation walls exceeding 6 mm in width, and ○ Other cracks or potential sources of water leakage, including joints between basement floors and foundation walls, as determined by the authority having jurisdiction, homeowner and/or builder.

Part B: Extreme Wind/Tornado Protection

It has been estimated that 230 tornadoes occur every year in Canada, though only an average of 62 are reported.⁸⁰ Southern Ontario is one of Canada’s most active tornado regions (Figure B1),⁸¹ and increasing population densities and urbanization will increase the likelihood that human populations will encounter tornado events.⁸² While it is not possible to “tornado proof” homes, it is possible to “harden” wood-frame construction homes to the impacts of extreme wind events.⁸³ Designing and building wood frame homes to resist EF2 tornadoes is reasonable given current wood frame home construction techniques in North America (see Table B1). The purpose of this section is to identify reasonable means of increasing resistance of homes to the impacts of tornadoes in the southern Ontario context.

As 98% of tornadoes in Canada are EF2 or less,⁸⁴ adoption of provisions that provide resistance up to EF2 tornado damage would serve to significantly reduce tornado damage risk. The Oklahoma Uniform Building Code Commission has adopted provisions that provide “...prescriptive based requirements for construction [residential structures] meeting or exceeding 135 mph [217 km/h] wind event corresponding to an EF2 tornado rating.”⁸⁵ It should be noted that much of the damage that occurs during tornado events does not result from a “direct hit” with the highest intensity portions of tornado tracks—many buildings located on the periphery of tornado tracks are damaged by less intense winds. Thus, application of measures that would reduce risk from lower intensity tornadoes (EF2 or less) can serve to mitigate damage in the periphery of high intensity (EF3 and higher) tornado tracks.⁸⁶

Figure B1: Confirmed and possible tornadoes in Canada, 1980-2009 & tornado-prone regions

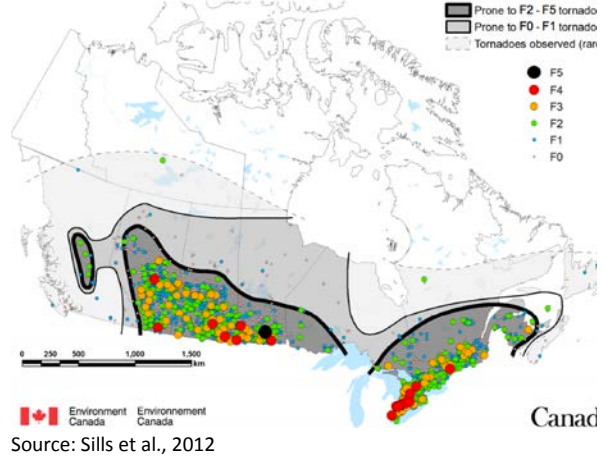

Table B1: EF-Scale wind speeds used by Environment Canada

EF-Scale rating	Wind speed (km/h)
0	90-130
1	135-175
2	180-220
3	225-265
4	270-310
5	315 or more

Kopp et al. 2017

Vulnerability of Ontario Homes to Tornado Damage

Recent damage investigations in southern Ontario illustrate vulnerabilities of relatively new homes to tornado damage, including investigations following tornadoes affecting Vaughan⁸⁷ and Angus⁸⁸ Ontario.

Observations following these events indicated that roof-to-wall

connections (RTWCs) are often the weakest link in the vertical load path for wood-frame homes.⁸⁹

On August 20, 2009, a total of 19 tornadoes occurred across southern Ontario—the most prolific outbreak of tornadoes recorded in Canada. EF2 tornadoes struck both the communities of Woodbridge and Maple, located in Vaughan. Media reports suggested that hundreds of homes were damaged during this event.⁹⁰ A

Figure B2: Structural roof failures (Angus, ON 2014)



Source: Kopp, G. 2014. Presentation to ICLR

damage survey conducted by Western University researchers focused on 92 damaged homes, 40 of which experienced major structural damage. Thirty homes experienced failures of RTWCs, 27 of which experienced loss

of major portions of the roof. Ten additional homes experienced sheathing failure, with some homes losing 50% of their roof sheathing.⁹¹

Porch overhangs, inability of porch roof columns to resist uplift forces, and failure of doors, including garage doors, also contributed to damages. Observations indicated that breaches in large windows and garage doors caused by flying debris were linked to structural roof failure. It was argued that EF2 damage could be considerably mitigated by use of hurricane ties. Non-integral garages were considered particularly vulnerable to roof failure, due to their small volume and failure of garage doors.⁹²

The June 17, 2014 Angus EF2 tornado exemplified the vulnerability of relatively new home construction, as many of the homes damaged during this event were less than three years old. A total of 101 homes experienced some level of damage. Eleven (10%) of the damaged homes lost their roofs. Ten of these roofs became completely detached, blowing off of the structure and impacting neighbouring homes. Missing toe-nail connections were observed during damage investigations, and failure to fasten the second floor wall to the floor resulted in structural wall failure in one instance. Nine homes experienced structural wall damage.

Construction and Inspection Issues

A strong roof is essential to ensure the safety of inhabitants and prevent excessive damages (due to water ingress during wind storms) to OBC Part 9 wood frame structures. Adequate connection of roof rafters, joists and/or trusses to wall framing increases the resistance of the roof system to windstorm conditions and reduces the risk of structural damage. It has also been noted that the uplift capacity of toe-nail connections does not meet the required wind resistance capacity for a basic house, as specified in Canadian construction codes.⁹³ It is further noted that loss of roof structure is usually the precursor to wall collapse⁹⁴ and that roof failure causes downwind debris impacts on adjacent buildings. Both wall collapse and flying debris can cause death and injury during windstorm events.

Post-tornado and hurricane damage investigations in Ontario and elsewhere have revealed recurring construction errors that have contributed to vulnerability of wood frame construction to high wind events. These errors included missing RTWCs and missing roof sheathing fasteners. Following the Angus, ON tornado, a post-storm field survey indicated that “much of the structural roof and wall damage was associated with poor construction quality caused by missing toe-nails in the roof-to-wall connections and nails in the inter-story wall-to-floor connections” and that almost

Figure B4: Wall failure indicating issues with construction (Angus, 2014)



Source: Kopp, G. 2014. Presentation to ICLR.

Figure B3: Incorrect roof-to-wall connection (Vaughan, 2009)



Source: Kopp, G. 2014. Presentation to ICLR.

all of the toe-nailed RTWCs identified following the Angus tornado “...were below code requirements, with cases of zero, one, and two nails in the connections, rather than the code-required three.”⁹⁵

Homes damaged in Maple were largely newer construction, and experienced similar RTWC failures as older homes in Woodbridge. Missing RTWCs both resulted in direct damage to homes and contributed to the wind-borne debris field, increasing damages for adjacent homes. Missing just one toe-nail (two instead of OBC required three) on RTWCs can reduce uplift resistance by 40%, and can cause roof failure at 23% lower median wind speeds.⁹⁶

Missing roof sheathing fasteners or fasteners missing trusses is a common construction error that results in sheathing failure during extreme wind events. This issue has been identified in several areas of Canada, including the Vaughan, 2009 and Bornham ON, 2007 tornadoes.⁹⁷

Forensic analysis conducted in eastern Canada has revealed “...buildings in which more than 90% of the occupants were killed or seriously injured did not have anchorage of house floors into the foundation or anchorage of the roof to the walls.”⁹⁸ The OBC requires use of anchor bolts to tie building frames to foundations.⁹⁹ The experience of code officials and field observations have indicated that nuts and washers may not be installed in these connections in all cases. Ensuring that nuts and washers are in place is a critical aspect of ensuring life safety during tornado events.

Overview of Wind Risk Reduction Measures

Wind risk reduction measures presented in this document serve to address key vulnerabilities observed in the Canadian and Ontario context based on field and lab experience. The majority of the recommendations are presented under the categories of roofs and roof framing, and wall sheathing, fastening and connections. Post base and cap connections and garage doors are also addressed.

With respect to roofs and roof framing, the reader should note that hip roofs framed with engineered trusses are considered preferred means of reducing wind risk for low-rise, residential structures.¹⁰⁰ Engineered trusses are designed to withstand both compression and tension, and have performed well during high wind events in Ontario when compared to conventional (stick) roof framing. Nevertheless, it is recognized that a degree of flexibility should be incorporated into the recommendations presented below, as many new homes, notably custom homes, are constructed using conventionally framed roofs. Therefore, recommendations related to increasing the resilience of both conventionally framed roofs and gable roofs are presented here.

It should be further noted that measures presented below provide multiple risk reduction benefits for OBC Part 9 residential structures. These multiple benefits include improved resistance to snow loads (e.g., thicker roof sheathing), improved resistance to hail damage and the impacts of ice damming (e.g., ice-and-water shield), and risk associated with earthquake (e.g., improved bracing associated with structural grade plywood and OSB for wall and roof sheathing).¹⁰¹

Several of the recommendations contain multiple sub-recommendations (e.g., Recommendation 2, a *and* b). Use of the word “or” indicates that any one of the sub-parts may be adopted to satisfy the recommendation. Use of the word “and” indicates that multiple sub-parts should be adopted to satisfy the recommendation.

Extreme Wind Protection Measures

Roofs and Roof Framing				
#	Performance goal*	Options	Purpose	Notes
1.	<p>Roof framing and connection techniques should result in roof design that is capable of accommodating both compression and tension.¹⁰²</p> <p><i>And</i></p> <p>Where gable end walls are used, they should be appropriately braced and secured to resist forces during tornado events.</p>	<p>Preferred option:</p> <p>a) Use hip roofs framed using prefabricated, engineered trusses.</p> <p>Alternative to hip roofs:</p> <p>b) Gable roofs should adhere to the following provisions:</p> <p>i) Gable end walls should be tied to the supporting wall assemblies and roof framing. Connections should be present at tops and bottoms of end walls. Options may include steel connection plates or straps.¹⁰³</p> <p>ii) Sheathing and fastener methods for gable end walls should comply with recommendations #5 and #6 (see below).</p> <p>iii) Gable end wall sheathing should overlap the top plate of the loadbearing wall. Sheathing should be fastened to the top plate with 8d ring shank nails using 100 mm (4") o.c. spacing.</p> <p>Alternative to truss roof framing:</p> <p>c) Conventional roof framing should be engineered and capable of resisting wind loads as specified in Part 4 of the OBC, with $q_H=0.87$ kPa replacing the specified velocity pressure from SB-1 of the OBC.</p>	<ul style="list-style-type: none"> Apply roof framing, roof design, and sheathing measures to increase the resistance of roof structures to forces associated with high wind events. Assists in achieving continuous load path. 	<p>Engineered trusses:</p> <ul style="list-style-type: none"> Engineered trusses perform better than conventionally framed roof construction during tornado events, as they are capable of accommodating both compression and tension. <p>Hip roofs:</p> <ul style="list-style-type: none"> Hip roofs with engineered trusses have demonstrated higher resistance to uplift and failure of roof sections.¹⁰⁴ <p>Fastening gable end walls, structural sheathing for gable end walls:</p> <ul style="list-style-type: none"> Fastening of gable end walls results in gable end walls that are better able to resist suction forces during tornado events. Structural sheathing improves bracing. Nailing pattern reduces risk of nail pull-through. See Appendix B1 for methods applicable to recommendation 1.b i). See "Gable End Bracing" for additional information on common vulnerabilities for gable end walls and principles for bracing and securing gable end walls.¹⁰⁵ <p>Conventional framing:</p> <ul style="list-style-type: none"> Due to the varied and complex nature of conventional roof framing, conventionally framed roofs should be engineered. Conventionally framed roofs should be designed to accommodate forces associated with high wind events. The design wind pressure figure presented here (0.87 kPa) is based on the National Building Code of Canada design wind pressure for a moderate EF-2 (200 km/h) tornado. In this instance, a 3 second gust associated with the EF2 tornado event was converted to hourly average wind pressure (0.87 kPa).

*Performance goals and options are provided as part of Recommendation #1 to allow flexibility with respect to roof design and framing techniques. It should be noted that, based on lab and field research results in Canada, hip roofs framed with engineered trusses are considered the preferred roof framing and design method to increase resilience to high wind and tornado events.

#	Recommendation	Purpose	Notes
2.	<p>a) Tie roof rafters, roof trusses or roof joists to loadbearing wall framing with engineered connectors (commonly referred to as “hurricane ties”) that will resist a factored uplift load of 3 kN.¹⁰⁶</p> <p>And</p> <p>b) Builders should request that truss manufacturers supply appropriate roof-to-wall connectors along with trusses.</p>	<ul style="list-style-type: none"> By adequately connecting rafters, joists or trusses to wall framing, the resistance of the connection to uplift forces during windstorms is increased, decreasing the risk of structural damage. Requesting truss manufacturers to supply roof-to-wall connections ensures that appropriate connections are provided along with trusses. Assists in achieving continuous load path. 	<ul style="list-style-type: none"> Exceeds current toe-nail provisions outlined in OBC (Table 9.23.3.4. item 19). Connectors commonly referred to as “hurricane ties” may be used to meet this requirement. Note that hurricane ties may not be necessary if connections have been engineered to meet the referenced factored uplift load (3 kN). Use of hurricane ties increases ease of inspection of roof-to-wall connections, as the presence of clips can be easily seen. In comparison, toe-nail connections require that inspectors climb to roof level for inspection. The capacity of toe-nailed connections have been demonstrated to not meet the capacity necessary for design conditions for houses in Canada.¹⁰⁷ Note that OBC change request <u>2-CC-B-09-23-01</u> was under consideration at the time of writing of this document. The proposed change would require roof rafter, roof truss or roof joists to be tied to the wall framing with engineered connectors to resist higher uplift loads. The requirement presented here would become redundant if this code change request is integrated into the 2019 version of the OBC.¹⁰⁸ See manufacturers’ specifications for products that are capable of resisting a factored uplift load of 3 kN.
3.	<p>Install minimum 12.7 mm (½”) thick plywood or OSB roof sheathing, fastened with 8d ring shank nails.</p>	<ul style="list-style-type: none"> 12.7 mm (½”) plywood or OSB roof sheathing provides improved roof bracing. 	<ul style="list-style-type: none"> Nailing pattern will be in compliance with OBC 9.23.3.5(5) (150 mm [6”] spacing on edge and intermediate supports, when roof sheathing supports are placed at more than 406 mm [16” o.c.]). OBC 9.23.15.7: Currently, thickness varies from 5/16” to ½” depending on spacing of supports and sheathing type. For plywood, 12.7 mm (½”) is only required with 610 mm (24”) spacing of supports, when edges are unsupported. This recommendation assumes that roof trusses/rafters are spaced 610 mm (24”) o.c.¹⁰⁹
4.	<p>Install single layer of self-adhered modified bituminous membrane (ice-and-water shield) beneath roofing material.</p>	<ul style="list-style-type: none"> This requirement would result in application of ice-and-water shield over the entire roof, offering enhanced protection to the building from water damage in the event of roofing failure (e.g., when shingles are blown off during wind events). 	<ul style="list-style-type: none"> OBC 9.26.6 stipulates material and installation for underlay beneath shingles. A-9.26.6.1(1) states that some shingle manufactures require use of underlay beneath their products. Ice-and-water shield is commonly used to protect residential buildings from damage associated with ice damming. The recommendation presented here would result in extending the ice and water shield over the entire roof. Much of the damage caused to residential buildings during extreme wind events results from water penetration into the building.¹¹⁰ An additional advantage of this approach is added protection against water penetration associated with hail damage, and protection from the impacts of ice damming. Note that CWC 2014 includes provisions for 2-3 mm gaps between roof sheathing panel edges and end joints.¹¹¹

Wall sheathing and fastening			
#	Recommendation	Purpose	Notes
5.	Continuously sheath all walls with structural sheathing (OSB or plywood). ¹¹²	<ul style="list-style-type: none"> Continuous structural sheathing provides improved bracing. 	<ul style="list-style-type: none"> OBC 9.23.16.1. Required Sheathing “(1) Exterior walls and gable ends shall be sheathed when the <i>exterior cladding</i> requires intermediate fastening between supports or if the <i>exterior cladding</i> requires solid backing.” Continuous sheathing with OSB, plywood typically depends on cladding requirement. To comply with this provision, walls must be continuously sheathed with structural sheathing.
6.	Minimum thickness of wall sheathing should be 12.7 mm (½”) nailed with 8d ring shank nails spaced 150 mm (6”) along edges and intermediate supports.	<ul style="list-style-type: none"> 12.7 mm (½”) sheathing used for both roof and wall sheathing provides improved bracing. 	<ul style="list-style-type: none"> OBC 9.23.10.2 provides bracing and lateral support requirements. This OBC article is referred to in OBC A-94.1.1.(3) Structural Design for Lateral Wind and Earthquake Loads.¹¹³ A requirement of 12.7 mm (1/2”) thickness for OSB or plywood exceeds requirements provided in OBC Table 9.23.16.2.A. OBC Table 9.23.3.5 indicates that plywood and OSB between 10 and 20 mm in thickness must have fasteners spaced 150 mm (o.c.) along edges and 300 mm (o.c.) along intermediate supports. See also OBC Table 9.23.10.1 and related appendices, which provide specifications for stud spacing. For walls not listed in 9.23.10.1, minimum exterior sheathing required is 9.5 mm (3/8”). OBC table 9.23.10.1 – exterior wall supporting roof with or without attic storage plus 1 floor – with 38 mm x 89 mm (2x4s) spacing max is 406 mm (16”), with 38 mm x 140 mm (2x6s), spacing max is 610 mm (24”). This recommendation (#6) applies to both walls with stud spacing of 406 mm o.c. (16”) and 610 mm o.c. (24”) with 150 mm (6”) o.c. fastener spacing along edges and intermediate supports.¹¹⁴
7.	<p>a) Upper and lower storey structural wall sheathing should be nailed to common rim joist.¹¹⁵</p> <p><i>And</i></p> <p>b) Wall sheathing should be fastened to common rim joist with 8d ring shank nails using a 100 mm (4”) o.c. spacing along both the top and bottom edges of the rim joist.</p>	<ul style="list-style-type: none"> Applies to multi-storey construction. Assists in achieving continuous load path. Nailing pattern reduces risk of nail pull-through. 	<ul style="list-style-type: none"> Nailing pattern exceeds OBC requirements (OBC 9.23.3.5 indicates that plywood and OSB between 10 and 20 mm in thickness must have fasteners spaced 150 mm [o.c.] along edges and 300 mm [o.c.] along intermediate supports). Note: CWC 2014 includes provisions for spacing between sheathing panels to accommodate shrinkage of floor framing.¹¹⁶

#	Recommendation	Purpose	Notes
8.	<p>a) Structural wall sheathing should be extended to lap the sill plate.¹¹⁷</p> <p><i>And</i></p> <p>b) Sheathing should be fastened to sill plate with 8d ring shank nails using 100 mm (4") o.c. fastener spacing.</p> <p><i>And</i></p> <p>c) Fasten wall sheathing to rim joist (if present) with 8d ring shank nails using 100 mm (4") o.c. spacing along both top and bottom edges of the rim joist.¹¹⁸</p>	<ul style="list-style-type: none"> Helps tie structure to the foundation, assists in achieving continuous load path. 	<ul style="list-style-type: none"> Nailing pattern exceeds OBC requirements (OBC 9.23.3.5 indicates that plywood and OSB between 10 and 20 mm in thickness must have fasteners spaced 150 mm [o.c.] along edges and 300 mm [o.c.] along intermediate supports).

Figure B5: Upper and lower storey sheathing fastened to common rim joist, and lapping of sill plate with wall sheathing

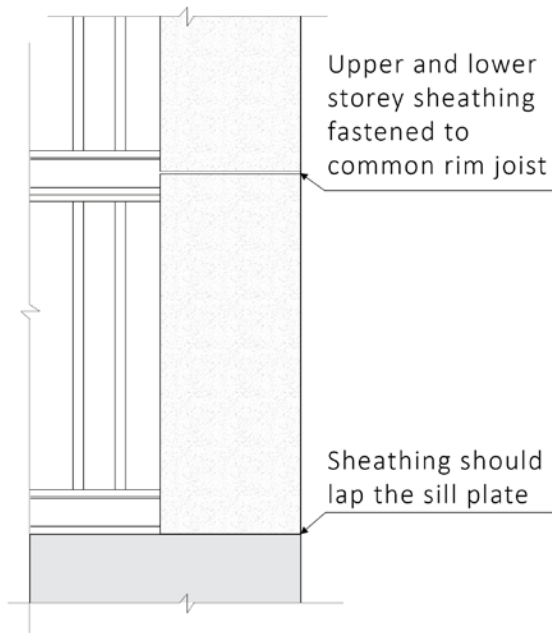

Post base and cap connections			
#	Recommendation	Purpose	Notes
9.	<p>a) Hot-dipped galvanized or stainless steel post cap and base connections rated for at least 6.8 kN (1,536 lbs) allowable uplift loads should be used for post base and post cap connections.</p> <p><i>And</i></p> <p>b) Post base connections should be embedded in, or fastened to concrete slabs for front and rear porch applications.</p> <p><i>And</i></p> <p>c) Fasteners used for post base connectors should be hot-dipped galvanized or stainless steel.</p> <p><i>And</i></p> <p>d) Post and cap connections must be visible for the purposes of inspection.</p>	<ul style="list-style-type: none"> • By adequately attaching porch roof support beams to their posts, and posts to their foundation, the resistance of the posts to uplift forces during windstorms is increased, decreasing the risk of structural damage. • Currently porch columns are often toe-nailed to foundations, which provides insufficient uplift capacity. • Use of visible connectors (i.e. connections that extend above the base of posts) increases the ability to inspect post base and cap connections. 	<ul style="list-style-type: none"> • See OBC 9.23.6.2 for post base and post cap connections for attached structures.¹¹⁹ Uplift capacity is not provided for in this Article. This additional requirement provides consistent guidance for post base and cap connections. • OBC 9.35.4.3 (1) contains provisions for anchorage of garage and carport walls and columns. An uplift capacity for anchorage is not specified.¹²⁰ • The 6.8 kN figure is based on the following assumptions:¹²¹ <ul style="list-style-type: none"> ○ 2.44 m (8') wide porch, ○ 2.44 m (8') between posts, ○ Porch weight of 0.48 kPa (10 psf), ○ Open terrain wind exposure, and ○ 1/50 year wind exposure of 0.8 kPa. • See manufacturers' catalogues for uplift ratings of post base and cap connectors. • Install connectors according to manufacturers' instructions.

Garage doors			
#	Recommendation	Purpose	Notes
10.	Garage doors should be rated to 217 km/h (135 mph) wind or above. ¹²²	<ul style="list-style-type: none"> • Garage door failures result in increased internal pressure during tornadoes, resulting in roof failure and increasing wind-borne debris. 	<ul style="list-style-type: none"> • Garage doors are a weak point in the building envelope and breaches of garage doors have been observed to result in roof failure in post-tornado damage assessments in Ontario.

Appendix B1: Gable End Wall Support and Bracing Options

Lateral Support at Gable End Walls¹²³

The Canadian Wood Council's *Engineering Guide for Wood Frame Construction* (2014 Edition) provides the following guideline for lateral support at gable end walls:

Lateral Support at Gable End Walls

These guidelines are additional to the Part 9 prescriptive requirements of the NBC

These guidelines for lateral support of gable end wall apply in high wind areas where $0.8 \leq q_{1/50} \leq 1.2$.

Gable end walls are braced as shown in [below figure] by:

- 38 x 89 mm continuous lateral bracing spaced 1.6 m o.c. nailed with two – 76 mm common nails into each truss bottom chord or each ceiling joist.
- 38 x 89 mm blocks between the first truss or ceiling joist and the gable end truss nailed to the continuous lateral bracing with four 76 mm common nails.
- 20 gauge strapping nailed to the continuous lateral bracing and endwall studs using ten 64 mm common nails at each end.

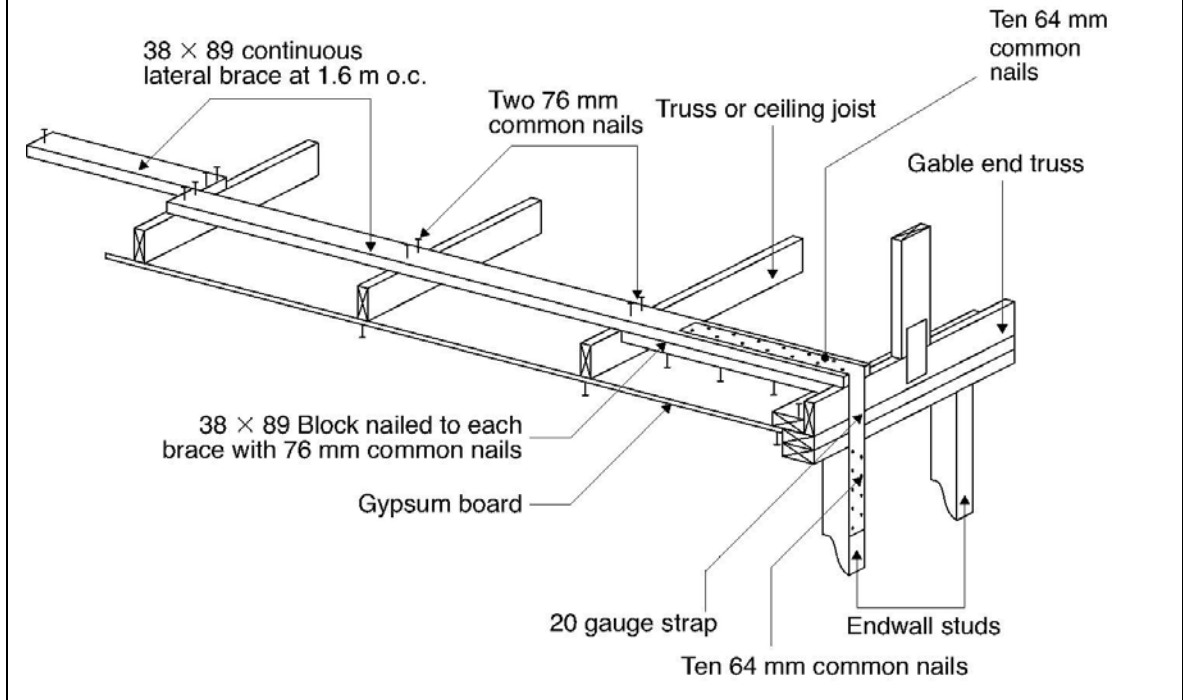

The following excerpts of images and text are from Building Component Safety Information (BCSI) Canada. 2014. **Guide to Good Practice for Handling, Installing, Restraining and Bracing of Metal Plate Connected Wood Trusses.** Produced by Structural Building Components Association (SBCA), Truss Plate Institute (TPI), and Truss Plate Institute of Canada (TPIC). For more information, visit sbcindustry.com. Used with permission.

Building Designer Responsibilities for Gable End Frame Bracing¹²⁴

The building designer, knowing the intended flow of Loads for the entire building, is responsible for taking the resultant Loads that exist within the Gable End Frame and safely transferring the Loads through additional Bracing from the Gable End Frame to the roof and Ceiling Diaphragms.

Gable End Frame Bracing is designed by considering a number of factors including:

- The length, spacing, species and size of the Gable End Frame studs
- Gravity Loads
- Lateral Loads (wind and seismic)

The Building Designer, through detailing in the Construction Documents, is responsible for all Gable End Frame Bracing, including the Bracing member size and locations, attachment to Trusses, gable end sheathing, and fastener size and locations including any mechanical Connectors required.

Other factors the Building Designer shall consider include:

- Thickness and type of roof, wall and ceiling sheathing
- Transfer of Load between the Gable End Frame Bottom Chord and wall below
- Attachment of Structure Sheathing to the wall/Gable End Frame interface and attachment of wall to foundation to resist uplift and lateral Loads

In service, Gable End Frames also experience lateral Loads parallel and perpendicular to their plane. The Gable End Frame shall be incorporated into the wall design by the Building Designer.

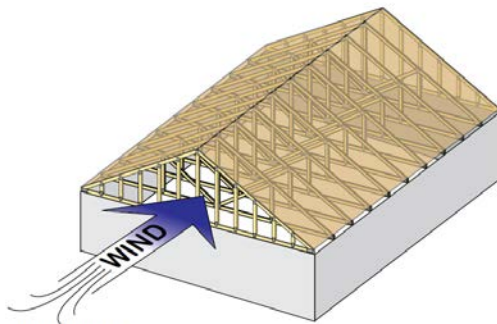

FIGURE B3-25

Truss Designer Responsibilities for Gable End Frame Reinforcement

The Truss Designer must note on the [Truss Design Drawing] for the Gable End Frame the type and location of Permanent Individual Truss Restraint (PITMR) required to resist the vertical Loads assumed in the design of the frame. Examples include single or double L, T, U, Scab, horizontal L or any other means of reinforcement deemed appropriate to restrain the out-of-plane buckling on the vertical “studs.”

The Truss Designer is responsible for indicating the loading and environmental design assumptions used in the design of the Gable End Frame to conform to the Loads specified in the Construction Documents.

Contractor Responsibilities for Gable End Frame Bracing

The Contractor is responsible for properly installing the Gable End Frame as detailed in the Construction Documents and within the Truss Submittal Package.

Gable End Frame Bracing/Reinforcement Requirements

If the lateral Load is large enough, and the vertical studs are long enough, the Gable End Frame may require Bracing to prevent it from rotating at the Gable End Frame/end wall interface, along with Diagonal Bracing and/or Web Reinforcement to prevent the vertical Webs from bending excessively. Serviceability failures often occur if the Gable End Frame is not properly braced.

Gable End Frame Bracing/reinforcement helps prevent these types of serviceability failures and safely transfers forces from the Gable End Frame into the associated Diaphragms.

Typical Gable End Frame Bracing/reinforcement details include Blocking at the ceiling and roof level Diaphragms, gable stud reinforcement, horizontal reinforcement and/or Diagonal Bracing, mechanical Connectors/straps and specific fastener size and frequency schedules.

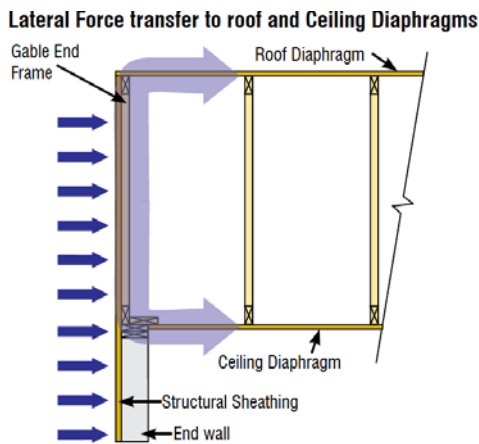

FIGURE B3-27

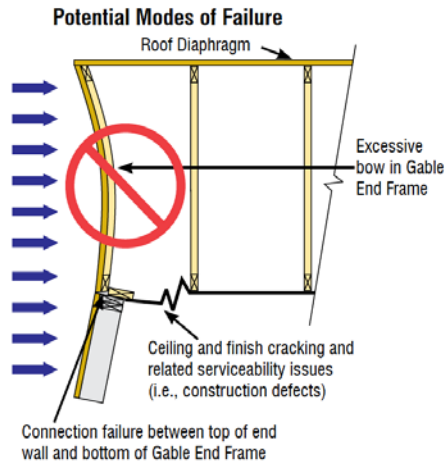

FIGURE B3-28

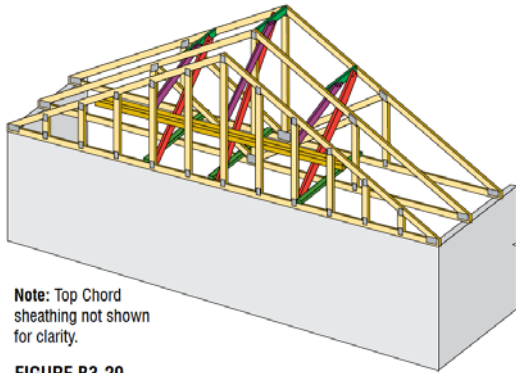

FIGURE B3-29

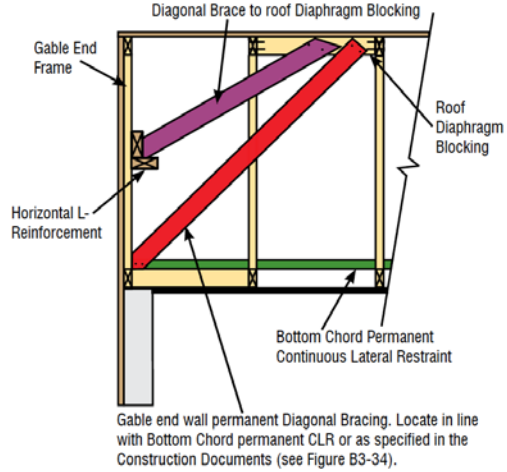

FIGURE B3-30

Note: The Diagonal Brace from the top of the end wall to the top chord of the Truss will impart a vertical force to the Truss Top Chord. This is in addition to any uplift forces the roof sheathing will impart to the Truss from wind. The Loads from this brace must be considered in the design and attachment of the supporting Truss.

✓ Examples of Gable End Frame Web Reinforcement.

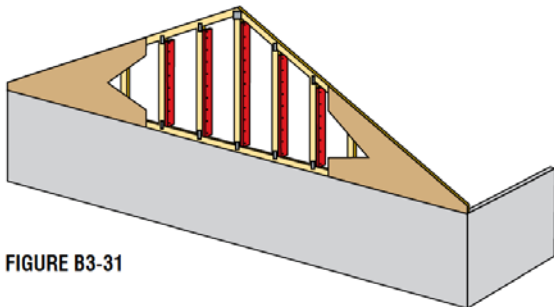

FIGURE B3-31

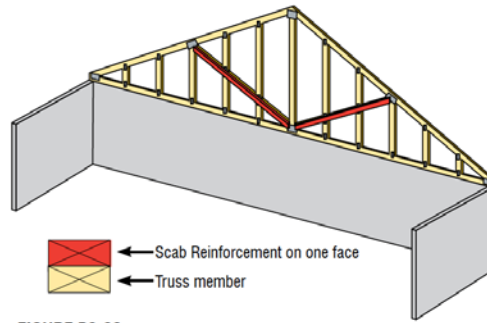

FIGURE B3-32

Part C: Extreme Heat Protection

North America is expected to experience more frequent, more intense, and longer lasting extreme heat events under changing climate conditions.¹²⁵ By 2049, the number of extreme heat events per year—defined as at least three consecutive days with temperatures greater than 32°C—in the Greater Toronto Area (GTA) is expected to rise from 0.57 to 2.53.¹²⁶ These events will strain the region’s power supply and increase risk of overheated buildings. Vulnerable groups such as older adults, young children, and the isolated are at a heightened risk of heat related morbidity and mortality. Historically, heat waves have caused more mortality than any other natural hazard in Canada. The impact of individual heat wave events can be catastrophic. For example, heat waves resulted in the death of 1,180 people in Canada¹²⁷ in 1936, 739 people in Chicago in 1995, 70,000 in Europe in 2003, and 280 people in Quebec in 2010.¹²⁸ Toronto’s annual average heat related mortality could more than double by the 2050s.¹²⁹

Between 2005 and 2015 the two largest increases in population in Durham Region were in the 90+ and 85-89 age cohorts.¹³⁰ In 2015, it was estimated that there were over 91,000 Durham residents aged 65 years and older. This senior age cohort is projected to grow and will soon become the largest demographic group in Durham Region. With the expected increase in extreme heat events, as well as an increasingly vulnerable aging population, measures to reduce the impacts of heat are needed in Durham Region. Other considerations such as automobile dependent development and accessibility of houses also need to be considered in an effective approach to heat adaptation, but are beyond the scope of this Standard.

Overheating in ground-oriented homes is generally caused by external and internal heat gains. External heat gains (Figure C1) can be caused by solar radiation on windows and walls, transmission of heat through the building envelope when exterior temperature is higher than interior temperature, and warm outside air entering the building through open windows, doors, or openings in the building envelope.¹³¹ Appliances, lights, and people cause internal heat gains in homes.

Figure C1: Example sources of external heat gains to houses.

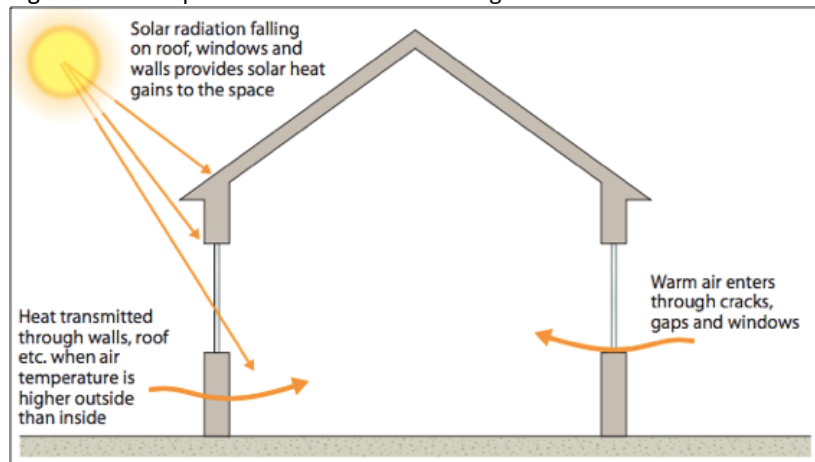

Chartered institution of building services engineers London. How to Manage Overheating in Buildings. 2010.

Mechanical cooling techniques including air conditioning are expensive, energy intensive, and are vulnerable to power outages.¹³² Passive cooling measures may be applied to reduce reliance on mechanical cooling techniques and to add a factor of safety for vulnerable residents during heat waves and during power outages. Municipalities, builders, and homeowners have explored and adopted multiple strategies for becoming more resilient to extreme heat events. For example, Toronto and Montreal have implemented green and cool roof incentive programs, Geneva, Switzerland has a window retrofit requirement, and Stuttgart, Germany uses pale building surfaces and pavement in an effort to reduce solar radiation absorption.

Heat Resilience in Canada

Passive Design, climate adaptation design, or climate responsive design are defined as approaches to building design that use “...the building architecture to minimize energy consumption and improve thermal comfort.”¹³³ Recent proposed changes to the OBC (Specifically, proposed change 2-CC-B-12-02-04) relate to increasing energy efficiency in new buildings for 2020 and 2022.¹³⁴ Proposed changes that relate to heat adaptation in new homes

include lower U-value windows, air tightness testing, and continuous insulation. Victoriaville, Quebec rewards homeowners and builders for adopting energy efficiency and heat resiliency measures in both existing and new buildings. Many of these practices promote passive cooling and thermal comfort. Examples of heat resiliency measures promoted by Victoriaville include greater R-value insulation in foundations, walls and roofs, windows with lower U-values, and exterior window shading to minimize heat gains.

The Province of British Columbia also encourages energy efficient and heat resilient construction. The Province recently began implementation of the BC Energy Step Code, a section of the provincial building code that governs energy efficiency and greenhouse gas emissions for Part 9 buildings. The Step Code provides the necessary resources and guidelines for different levels (or steps) of energy efficiency, and municipal governments can choose which step to implement. The purpose of the step code is to streamline energy efficiency standards, provide incentives and resources for innovative municipalities, and create a framework for higher overall sustainability through the BC Building Code. The City of North Vancouver has worked with developers to achieve high steps in the Step Code in exchange for added density in the planning process.

Current initiatives in Ontario, Quebec and British Columbia show that new construction offers an opportunity for increasing the stock of heat resilient homes. Buildings that are designed to promote passive cooling and higher levels of thermal comfort are more likely to keep cool during summer power outages and extreme heat events, thereby reducing the risk of morbidity and mortality. Recommendations presented here for reducing overheating of low-rise residential structures include building design, building materials, and landscaping approaches. While most of these measures can be implemented in both new and existing homes, passive cooling and thermal comfort is optimized when measures are integrated early in the design process of a building.

Design Strategies for Passive Cooling

Passive cooling design optimizes a house’s orientation, shape, glazing, and placement of glazing to limit overheating during heat waves and power outages. Decisions regarding the placement and size of windows can make houses more resilient towards extreme heat by both influencing the amount of glazing that is exposed to the sun, and promoting cross-ventilation inside the building (Figure C2). Placing windows on opposite sides and at different heights of the building promotes the flow of air through the building.

Figure C2: Example Passive Cooling Techniques: Cross-Ventilation¹³⁵

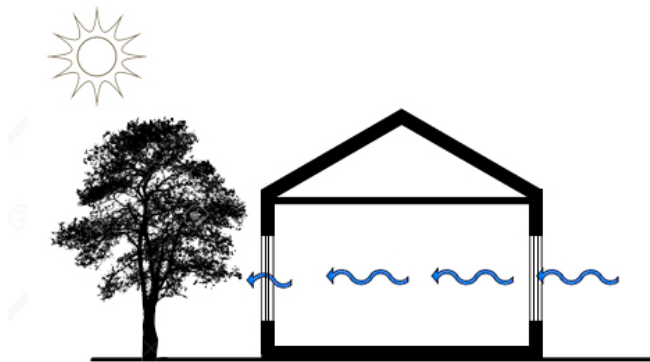

Materials used in new home construction can also affect passive cooling. For example, double or triple glazed windows with low U-values, insulation in walls and roofs with higher R-values, and light or solar reflective building exteriors reduce risk of overheating and serve to reduce energy use. Reflective building exteriors may also help to reduce local urban heat island (UHI) effects.

Landscaping and exterior shading (e.g. exterior window shutters or shading trees near west-facing windows) are additional measures that serve to minimize solar heat gains through windows. Various approaches can be used to

shade windows, with higher shading coefficients usually associated with exterior shading devices (window shutters, solar shelves, trees, *brise-soleils*, etc.) rather than internal blinds.¹³⁶ Examples of these external shading measures are provided in Figure C3.

Figure C3: Example External Shading Options¹³⁷

Covered porches



Insulated exterior roll shutters



Vertical or horizontal louvers



Exterior screen



Urban Planning Approaches for Heat Resilience

While this document focuses on low-rise, residential (OBC Part 9) buildings and measures that can be applied to reduce heat wave risk on the private-side of the property line, it is important to note that wider, regional-scale planning efforts are required to mitigate risk and manage impacts of heat waves and UHI. Notably, objective HH3 in the Durham Community Climate Adaptation Plan is to reduce ambient summer temperatures in urban areas in order to reduce heat stress.¹³⁸ Urban planning and design strategies can be implemented at the block, town, or city level to optimize passive cooling. For instance, streets in new subdivisions can be planned in a grid layout with longer blocks along the east and west axis, allowing for most homes to face north or south, and have neighbouring homes shade east and west exposures. Streets, open spaces, and buildings can be planned in a manner that promotes radial ventilation. Wide roads with vegetated shoulders and medians, and open linear parks of 100m or more in width can increase urban cooling during summer nights. This strategy is particularly effective when these open spaces are parallel to prevailing summer winds. In addition to open space considerations, planning for compact buildings and density should be promoted. For example, buildings can benefit from shared shade (i.e. placement of buildings in a manner that allows them to shade each other).

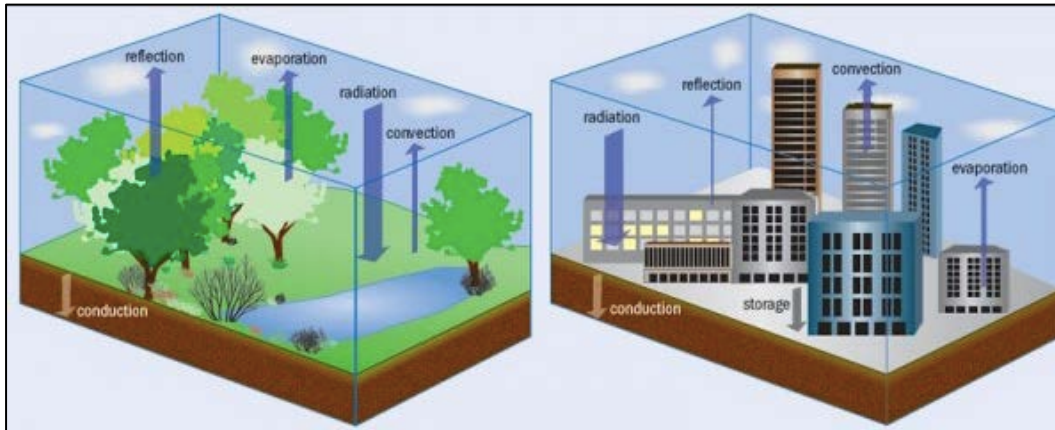
Figure C4: Urban Heat Island Effect.¹³⁹

These wider-scale urban planning strategies are beyond the scope of this project; however, many of the building and site-scale recommendations presented here contribute to reduction of the UHI effect. Green and cool roofs, tree planting, increased vegetation and solar reflective cover not only provide shading and cooling for individual buildings, they can also reduce local air temperature. Suburbs with mature trees have been found to be 2-3°C cooler than suburbs without mature trees.¹⁴⁰ Planting of new trees is vital to building healthy communities, but it is noted that preserving existing trees and natural heritage features is also important. These strategies work best when considered in the urban planning and design phase of new subdivisions.

Developing a Strong Basis for Prescriptive Building Envelope Performance Requirements

Implementing strong levels of envelope performance is critical to maintaining indoor thermal comfort and managing overheating risk. When developing building envelope requirements, the interdependency between overheating and energy efficiency should be properly considered. Development of appropriate envelope performance requirements necessitates an understanding of the relationship between building form, orientation, insulation levels and airtightness, window placement and treatment, and shading. Technical Committee participants argued that presentation of prescriptive requirements for insulation and airtightness in the absence of a suitable evidence base (informed using full-building energy modelling studies) is not typically considered an effective method of addressing building envelope performance for new home construction. As such, Technical Committee members encouraged the development of energy modelling studies for the purposes of establishing reliable, effective and responsible envelope performance requirements.

Several measures related to envelope insulation and air tightness obtained from best practice programs and initiatives (including LEED, OBC SB-12 proposed changes, ENERGY STAR, the Sustainable Housing Program in Victoriaville, Quebec and the City of Vancouver's Energy Efficiency Updates to Vancouver's Building By-law, etc.) are presented in Appendix C1. These measures are presented as "example measures" based on existing prescriptive recommendations, and are not considered requirements of this standard. Whole-building energy modelling would be required to help answer several key questions:

- Assessing and understanding trade-offs associated with R-values (for attics, walls, basement floor slabs, foundation walls, exterior walls), U-values for windows, and continuous insulation and air tightness values,
- Assessing and understanding potential trade-offs between keeping buildings cool in the summer and reducing energy consumption in the winter,
- Understanding the role of HVAC/mechanical equipment, and
- Assessing and understanding diminishing return on investment associated with higher insulation values.

A cost-effective approach to understanding envelope performance in Durham Region could focus on developing modelling results for a number of typical "archetype" house designs. The result of such an approach would be

reliable prescriptive envelope and airtightness recommendations without requiring energy modelling studies for each building constructed in the Region. A similar approach was recently applied to develop prescriptive envelope and air tightness requirements for Part 9 buildings in the City of Vancouver. This study focused on understanding the performance of a number of archetype structures (e.g., 1 and 2 family residences), and development of prescriptive requirements based on this work. Table C1a in Appendix C1 provides envelope requirements associated with these archetypes, and Table C1b in Appendix C1 includes a further example of archetype housing types developed for the purposes of the BC Step Code costing study.

Overview of Extreme Heat Protection Measures

Multiple municipal, provincial and national initiatives are underway that aim to increase the energy efficiency of low-rise residential buildings. Many of the measures that promote energy efficiency in buildings also have the potential to affect overheating risk. Appendix C2 outlines several of these initiatives. It is further noted that the Region of Durham Community Climate Change Local Action Plan—a plan focused on climate change mitigation—includes a proposed initiative aimed at developing a green building guideline to promote more energy efficient construction—a project that would have implications for building overheating risk reduction.¹⁴¹

Measures presented in this document are meant to complement the above-noted body of work by filling key “gaps” identified by Durham Region climate change adaptation staff and members of the Heat Technical Committee involved in the development of this document. This document is meant to both identify readily available prescriptive measures, as well as opportunities for further development and exploration of heat-mitigation measures for the Durham Region context.

The risk that high energy efficiency building initiatives, including Vancouver’s Zero Emissions Building Plan, the BC Step Code and Net Zero Energy Homes, will increase dwelling overheating risk has been discussed elsewhere.¹⁴² Measures that have been proposed to offset overheating risk in these instances have included operable windows allowing for adequate natural ventilation, reduced solar heat gain coefficients for windows, and window shading provisions, all of which are included in the recommendations presented here.

Measures presented in this document, while focused on management of heat-related impacts, have additional benefits related to energy efficiency. These co-benefits are noted below. Further, conflicts between measures presented in Part C of the Standard and those presented in Parts A (Basement Flood Protection) and B (Extreme Wind Protection) are noted and mitigated to the extent possible. For example, awnings provide shading for windows. While beneficial for heat impacts, these measures could increase the risk of wind damage and thus may be considered as conflicting with the intent of Part B. Technical Committee members further highlighted the need to ensure that landscaping should comply with FireSmart landscaping guidelines and should not increase risk of wildland urban interface fire, where appropriate in Durham Region.¹⁴³

Finally, it was recognized during development of Part C that many key decisions that affect heat vulnerability and energy consumption must be made during the early subdivision design and planning stages. As measures presented in this document are focused on the private-side of the property line, these early-planning related strategies are considered outside of the scope of this document.

Extreme heat protection measures presented here are considered as either “primary” or “enhanced” measures. Measures identified as “primary” by the Technical Committee were considered to have significant risk reduction benefits and are generally available for implementation for new homes in Durham Region. Enhanced protection measures include measures that would assist in reducing overheating risk, but may not necessarily be appropriate in all circumstances (e.g. may be considered redundant, may limit choice in home design, or may be technically complex, and/or expensive).

Several of the recommendations contain multiple sub-recommendations (e.g., Recommendation 3. a and b). Use of the word “and” indicates that multiple sub-parts should be adopted to satisfy the recommendation.

Extreme Heat Protection Measures (Primary)

Shading, Glazing, and Window Operability			
#	Recommendation	Purpose	Notes
1.	Shading overhangs should be provided for all south-facing windows.	<ul style="list-style-type: none"> Reduction in summer-time solar heat gains through south facing windows. The value (P) is adjusted to Durham Region’s climate and sun angle to ensure shading only occurs in the summer allows for passive heating in winter (Figure C5). 	<ul style="list-style-type: none"> Currently no shading requirements are incorporated into the OBC. The angle of sun during the summer solstice in southern Ontario (43° latitude) requires the length (P) in the formula $P=H/X$ for solar shading for south facing windows and doors (see Figure C5). Projection or horizontal length from exterior wall to outer most point of overhang = window height/X (X may vary between 2.0 and 2.5).¹⁴⁴ Can be substituted to use a different shading measure from #2, depending on site factors. Roller shutters are effective, but require active operation (closing during extreme heat events). Because awnings/overhangs do not require operation they are preferred over shutters. Alternatives to awnings/overhangs should be applied for the purposes of wind damage mitigation. External shading is more effective than internal blinds for reducing heat transfer through windows.¹⁴⁵
2.	East and west facing windows should be shaded.	<ul style="list-style-type: none"> Reduction in solar heat gains through west and east facing windows. 	<ul style="list-style-type: none"> West and east facing windows are the most difficult to shade in the summer. Limiting glazed exposure is ideal, but if it is not possible, exterior shading to block solar radiation is recommended. Shading options may include shading by neighbouring buildings, opaque fences, tall and dense hedgerows, operable shutters, overhangs, etc. Recommended by Florida Solar Energy Centre¹⁴⁶ and City of Vancouver Passive Design Toolkit.¹⁴⁷ External shading is more effective than internal blinds for reducing heat transfer through windows.¹⁴⁸
3.	<p>a) Operable windows should be placed on opposite sides of building, or at different heights to allow for cross or stacked ventilation.¹⁴⁹</p> <p>And</p> <p>b) Each habitable room of the house should have at least one operable window. The window opening area should be at least 5% of the floor area of the room.</p>	<ul style="list-style-type: none"> Windows should be operable to allow for ventilation. In order to allow each occupant of the building to adapt and optimize their thermal comfort, each habitable room should have operable windows.¹⁵⁰ 	<ul style="list-style-type: none"> Table 9.7.2.3.(1) of the OBC specifies minimum glass areas for rooms of residential occupancy. Recommended by the Chartered Institution of Building Services Engineers (CIBSE).¹⁵¹

#	Recommendation	Purpose	Notes
4.	Solar heat gain coefficient (SHGC) on all glazing should be maximum 0.4.	<ul style="list-style-type: none"> Reduces solar heat gains through windows. 	<ul style="list-style-type: none"> OBC covers only glazing U-values, currently there are no requirements for solar heat gain. OBC 9.7.3.3. (3) “Windows, doors and skylights, with or without storm doors or sash, that are installed in <i>buildings</i> where the intended use of the interior space will not result in high moisture generation shall have a maximum thermal transmittance (U-value) or minimum temperature index (I) in accordance with Table 9.7.3.3.” Currently maximum U-value for Durham Region is 2.0 for windows and doors and 3.0 for skylights. This recommendation may be achieved with solar films, low e coating, etc. This option does not require manual operation of shutters or awnings, and effectively reduces heat transfer. Proposed OBC changes for all windows include 1.4 maximum U-value by 2020, and maximum 1.2 U-value by 2022.¹⁵² Recommended by the Efficient Window Collaborative for areas with moderate air conditioning requirements.¹⁵³ ENERGY STAR window SHGCs vary between 0.25 and 0.80. ENERGY STAR recommends a SHGC ≤ 0.40 for North-Central regions.¹⁵⁴ Commentary related to net-zero energy homes has suggested that Super windows with triple or quadruple glazing and low-e coatings with U-Factors around 0.6 W/m²C or lower may be required to realize net-zero-energy houses.¹⁵⁵

Figure C5: The diagram below illustrates various shading options for south facing windows. Options may include awnings, overhangs, and *brise-soleils*. The formula $P=H/X$ may be used to size shading devices, where P represents the depth of the shading device, and H represents the distance between the window sill and the bottom of the shading device. The value X may vary between 2.0 and 2.5, depending on architectural preferences, site conditions, etc. Deciduous trees (Illustrations C and D) also provide shading alternatives for south facing windows.¹⁵⁶

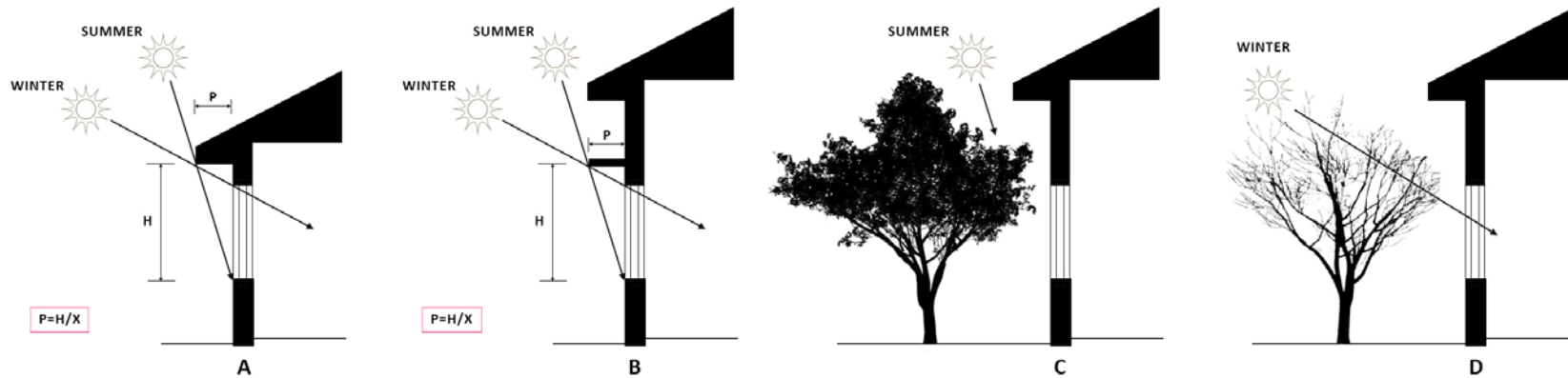

Roofs			
#	Recommendation	Purpose	Notes
5.	<p>Cool roofs should be installed, and should adhere to the following criteria:¹⁵⁷</p> <p>a) Minimum (3-year aged) solar reflectance (SR):</p> <ul style="list-style-type: none"> i) 0.55 for low-slope (1:6 or less) roofs ii) 0.20 for steep slope (1:6 or more) roofs <p>And</p> <p>b.) Maximum 0.75 thermal emittance (aged or new) for low and steep slope roofs</p>	<ul style="list-style-type: none"> • Reduction in solar transmission through roof. • Reduction in energy consumption. • Reduces UHI. 	<ul style="list-style-type: none"> • Cool roofs can serve to reduce reliance on air conditioning systems, improve thermal comfort for indoor spaces, reduce local air temperatures, among additional temperature and energy related benefits.¹⁵⁸ • Note that cool roofs may serve to increase energy requirements for heating, and may require maintenance to remain effective (e.g., dirtying of roof can reduce solar reflectance).¹⁵⁹ • The solar reflectance of roofs is not currently regulated by the OBC. • OBC proposed change 2-CC-B-05-10-01 would add Div. B, 5.10.4 and SB-14 and include cool-roof related provisions (“where a high-reflectance roof is installed, the roof is permitted to have a minimum 3 year aged solar reflectance index (SRI) of (a) 64 where the roof slope is 1 in 6 or less, or (b) 15 where the roof slope is greater than 1 in 6”). • Victoriaville, Quebec offers incentives for cool or reflective roofs. • LEED: 2 points for using ENERGY STAR qualified roof products in appropriately sloped applications. • Reflectance values for ENERGY STAR: low slope initial solar reflectance 0.65, 3-year aged 0.50; steep slope initial solar reflectance 0.25, 3-year aged 0.15.¹⁶⁰ • If different roofing materials are to be used, the average reflectance and emittance values of all materials should equal or exceed the prescriptive values identified in Recommendation #5. The average should be calculated based on the surface area for each material used.¹⁶¹

Figure C6: Solar Reflectance and Thermal Emittance of Roofs¹⁶²

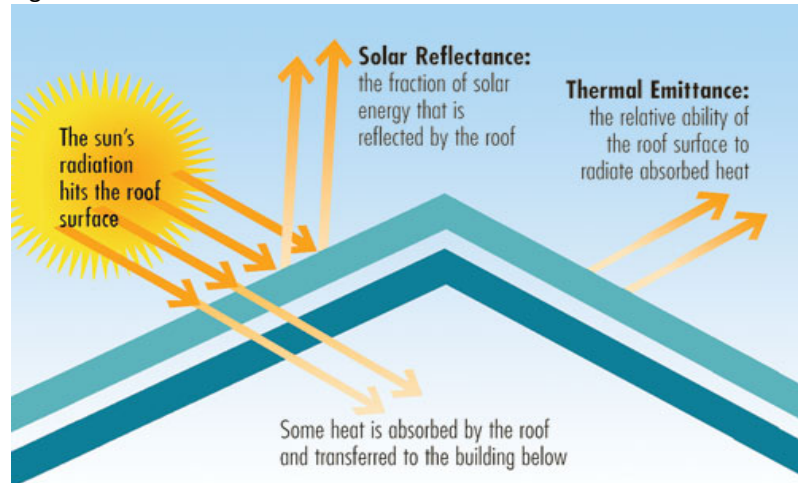

Landscaping			
#	Recommendation	Purpose	Notes
6.	Deciduous trees should be planted to provide shading for south, west and east facing windows.	<ul style="list-style-type: none"> • Shade reduces solar heat gains. • Reduces UHI in summer. • Creates “cooling off” space during extreme heat event. • Allows passive heating in winter (when leaves fall). 	<ul style="list-style-type: none"> • Recommended by City of Vancouver Passive Design Toolkit¹⁶³, and the US EPA for reducing UHI.¹⁶⁴
7.	Minimum 25% vegetation cover should be maintained on property (excludes property area covered by roofs).	<ul style="list-style-type: none"> • Reduces UHI. • Promotes evapotranspiration. • Regulates property microclimate. 	<ul style="list-style-type: none"> • LEED: 2 points for >75% of hardscape area (including roofs, but not common areas/roads) with shading (trees/plantings, calculated for noon at summer solstice, and at 10 years growth) or non-absorptive material (light-coloured, high albedo, or vegetation covered hardscapes – SR 0.28).¹⁶⁵ • Calculations should include all ground covering aside from building footprint (excluding roof area, but including patios, decks, paved surfaces, etc.). • Recommended by EPA for reducing UHI.¹⁶⁶ • This measure may also provide benefits related to stormwater flow attenuation. • Note: Should comply with FireSmart landscaping guidelines if property is at risk of wildland urban interface fire (where appropriate in Durham Region).¹⁶⁷

#	Recommendation	Purpose	Notes
8.	50% of all property hardscaping should have a minimum 0.3 solar reflectivity value (excludes property area covered by roofs).	<ul style="list-style-type: none"> Manages UHI and regulates property microclimate. 	<ul style="list-style-type: none"> 0.3 SR hardscaping required by Toronto Green Standard.¹⁶⁸ LEED: 2 points for >75% of hardscape area (including roofs, but not common areas/roads) with shading (trees/plantings, calculated for noon at summer solstice, and at 10 years growth) or non-absorptive material (light-coloured, high albedo, or vegetation covered hardscapes – SR 0.28).¹⁶⁹ This recommendation refers to yard surface only. In accordance with the Toronto Green Standard, 50% of all hardscaping surfaces must have a minimum of 0.3 solar reflectivity. Calculating an average reflectivity of all surfaces will not be considered adequate if less than 50% of hardscaping has a minimum of 0.3 solar reflectivity.¹⁷⁰

Extreme Heat Protection Measures (Enhanced)

Building Form and Orientation			
#	Recommendation	Purpose	Notes
9.	Compact building shape and open floor plan should be achieved by form factor <3 (form factor = floor area/total exposed surface). ¹⁷¹	<ul style="list-style-type: none"> Improves energy performance for cooling/heating Promotes cross ventilation (passive cooling strategy) 	<ul style="list-style-type: none"> Recommended by City of Vancouver Passive Cooling Design Toolkit,¹⁷² Passive House Institute.¹⁷³ LEED provides credit for decreased floor area to promote more compact residential buildings.¹⁷⁴

Landscaping			
#	Recommendation	Purpose	Notes
10.	Where possible, existing trees should be preserved on property before construction.	<ul style="list-style-type: none"> Newly planted trees take time to establish before they provide shading. 	<ul style="list-style-type: none"> Suburbs with mature trees have been found to be 2-3° cooler than suburbs without mature trees.¹⁷⁵

Appendix C1: Envelope Insulation and Airtightness Performance Examples

NOTE TO READER: It is recommended that Durham Region conduct energy modelling for a number of typical “archetype” house designs (see *Developing a Strong Basis for Prescriptive Building Envelope Performance Requirements* on Page 40 of this document). This section presents example prescriptive envelope and air tightness provisions that have been adopted or recommended in Ontario and in other jurisdictions.

Windows and Doors			
Practice #	Practice	Purpose	Notes
C1.1.	Total U-Values of 1.4 W/m ² K or below for all glazing (windows and doors). ¹⁷⁶	<ul style="list-style-type: none"> Improves heating and cooling energy efficiency. 	<ul style="list-style-type: none"> The City of Vancouver’s Energy Efficiency Updates to Vancouver’s Building By-law requires a total glazing U-Value of 1.4 W/m²K for single-family homes.¹⁷⁷ OBC 9.7.3.2. Heat Transfer Performance, “ Windows doors and skylights...shall be designed, constructed and installed to (a) minimize surface condensation on the warm side of the component and (b) ensure comfortable conditions for the occupants” OBC 9.7.3.3. (3) “Windows, doors and skylights, with or without storm doors or sash, that are installed in <i>buildings</i> where the intended use of the interior space will not result in high moisture generation shall have a maximum thermal transmittance (U-value) or minimum temperature index (I) in accordance with Table 9.7.3.3.” Currently maximum U-value for Durham is 2.0 for windows and doors. Proposed OBC changes for all windows include 1.4 maximum U-value by 2020, and maximum 1.2 U-value by 2022.¹⁷⁸
C1.2.	Maximum air leakage value of 1.65 L/s/m ² for glazing.	<ul style="list-style-type: none"> Reduces air leakage in cracks in fenestration. Improves energy efficiency. 	<ul style="list-style-type: none"> OBC 9.7.3.1 requires “windows, doors and skylights separating conditioned space from unconditioned space or the exterior shall be designed, constructed and installed so that, when in the closed position, they, ... (c) control air leakage”¹⁷⁹ Maximum 1.65 L/s/m² required for ENERGY STAR rating windows and doors.¹⁸⁰

Roofs			
#	Practice	Purpose	Notes
C1.3.	Minimum roof insulation values of R50 for ceilings with attic space; R31 for ceilings without attic space.	<ul style="list-style-type: none"> Reduction in solar transmission through roof. Reduction in reliance on mechanical cooling in summer. Reduction in energy costs for heating and cooling. 	<ul style="list-style-type: none"> SB-12 Table 2.1.1.2 A includes R50 for roofs with attic and R31 for roofs without attic. The City of Vancouver's Energy Efficiency Updates to Vancouver's Building By-law requires a R48 for ceilings with attic space and R28 for ceilings without attic space.¹⁸¹ Victoriaville, Quebec, requires a minimum insulation value of R51 for roofs.¹⁸² Nominal R-values are presented here.

Exterior Walls and Foundation			
#	Practice	Purpose	Notes
C1.4.	Minimum R22 insulation for above grade external walls.	<ul style="list-style-type: none"> Reduction in solar transmission through walls. Reduction in heating and cooling energy costs. 	<ul style="list-style-type: none"> OBC SB-12 Table 2.1.1.2 A includes minimum R22 for above grade external walls. Victoriaville requires a minimum insulation for exterior walls of R29.¹⁸³ The City of Vancouver's Energy Efficiency Updates to Vancouver's Building By-law requires R22 for both below and above grade walls.¹⁸⁴ Addressing thermal bridges may also be considered important when developing appropriate R-values for the Durham Region context. Nominal R-values are presented here.
C1.5.	Minimum R22 for foundation/basement walls.	<ul style="list-style-type: none"> Reduction in heat transfer through foundation. Reduction in heating and cooling energy costs. 	<ul style="list-style-type: none"> OBC SB-12 Table 2.1.1.2 A includes minimum R12 for basement walls. Victoriaville incentivizes R35 insulation for basement walls (highest level of incentives).¹⁸⁵ The City of Vancouver's Energy Efficiency Updates to Vancouver's Building By-law requires R22 for both below and above grade walls.¹⁸⁶ Nominal R-values are presented here.
C1.6.	Minimum value of R34 for concrete slab insulation.	<ul style="list-style-type: none"> Reduction in heat transmission through slab (energy efficiency benefits). 	<ul style="list-style-type: none"> Victoriaville incentivizes R34 (highest level of incentives).¹⁸⁷ The City of Vancouver's Energy Efficiency Updates to Vancouver's Building By-law requires R14 for concrete slab insulation.¹⁸⁸ Nominal R-values are presented here.
C1.7.	Minimum total building airtightness value of 3.50 ACH tested at 50 Pascals pressure.	<ul style="list-style-type: none"> Can prevent warm outdoor air from entering the building. Contributes to maintain thermal comfort for occupants. 	<ul style="list-style-type: none"> The City of Vancouver's Energy Efficiency Updates to Vancouver's Building By-law requires a value for total building airtightness of 3.50 ACH tested at 50 Pascals pressure.¹⁸⁹ Air tightness requires attention both in the initial design of a building and also through the construction phase. Particular attention is required to ensure air tightness associated with installation of doors, windows, parapets and envelope penetrations associated with mechanical, electrical and plumbing services.¹⁹⁰ For detail about ensuring building air tightness, see <i>Illustrated Guide: Achieving Air Tightness</i>.¹⁹¹

Table C1a: Prescriptive Envelope Requirements based on Archetype Housing Types Developed for the City of Vancouver¹⁹²

Components Metric (Imperial)	1&2 Family [Existing/Required]
Walls (above and below grade) RSI	3.85 (R22)
Flat or cathedral Roof RSI	4.3 (R28)
Full Attic RSI	8.5 (R48)
Under slab RSI	2.5 (R14)
Windows + sliding glass doors	U 1.4 (.25)
Airtightness (not converted M/l)	Testing + 3.5ACH ₅₀

Table C1b: Archetype Part 9 Homes Developed for the BC Step Code Costing Study¹⁹³

Archetype	Details
Multi-Unit Residential Building (10 units)	Market, 1,654 m ² /unit, 3 storey over underground parkade
Row House (6 units)	Market, 957 m ² /unit, 3 storey over underground parkade
Quadplex	Market, 513 m ² /unit, 3 storey over underground parkade
Large Single Family Dwelling	Market, 511 m ² , 2 storey with basement
Medium Single Family Dwelling	Market, 237 m ² , 2 storey with basement
Small Single Family Dwelling	Market, 102 m ² , single storey on heated crawlspace

Appendix C2: Overview of Energy Efficiency/Building Envelope Initiatives

Changes to OBC SB-12: SB-12 of the Ontario Building Code includes provisions related to energy efficiency. SB-12 offers selection between prescriptive compliance packages for envelope components including insulation (walls, windows, roofs, and basements) and airtightness, or performance requirements determined from energy modelling.

Prescriptive compliance packages currently offer tradeoffs between envelope and mechanical components. By 2020 these tradeoffs will be limited to envelope elements, and by 2022 all tradeoffs will be removed (during the transition to performance compliance). Over the next 15 years, SB-12 is proposed to require more stringent prescriptive values, eventually leading to mandatory performance requirements and net-zero energy homes. Generally, changes made to this OBC supplementary standard will result in homes that will be more air tight with a better-insulated envelope and glazing.

ENERGY STAR, R-2000, Energuide: ENERGY STAR requires either a prescriptive path or performance path (performance values based on Energuide rating) for envelope, appliances, and mechanical components of new homes, leading to homes that are 20% more efficient than code. The R-2000 voluntary standard provides both performance and prescriptive provisions in the form of a voluntary standard.¹⁹⁴ R-2000 (50% more efficient than code) also references Energuide ratings for energy efficiency requirements, and includes components related to clean air and the environment. All R-2000 homes and Performance Path ENERGY STAR homes receive an Energuide rating from 0-100 (100 being the most efficient/net-zero). NRCan certified energy advisors are trained in energy modelling related to Energuide ratings.

Specific envelope and air change related provisions included in the R-2000 standard:

- Insulation:
 - Thermal insulation must meet or exceed provincial or local requirements,
 - Basement wall insulation must be applied to a substantial portion of basement walls (without any reduction in the RSI value),
- Air change rates:
 - Air change rates at 50 Pa no greater than 1.5 ACH (or Normalized Leakage Area at 10 Pa does not exceed 0.7 cm²/m² when measured in accordance with CAN/CGSB-149.10-86),
- Window performance:
 - Minimum requirements are for double-glazed window with a low-emissivity coating, inert gas fill, and an insulated spacer with a wood, vinyl or fiberglass frame.

Table C2a: Energuide Rating System¹⁹⁵

House Characteristics	Typical ERS Rating
Existing house, not upgraded	0-50
Upgraded existing house	51-65
Energy-efficient upgraded existing house	66-74
New house built to building code standards without energy requirements	70-76
New house built to building code standards containing energy requirements	77-80
Energy efficient new house	81-85
High-performance, energy efficient new house	86-99
Net-zero house (energy purchased and energy generated, through renewable resources, is equal)	100

BC Energy Step Code: The BC Step Code provides a “...performance based path intended to support a market transformation from current energy efficiency requirements to net-zero energy ready buildings by 2032.” The Step Code was developed in part to ensure a consistent approach to energy efficient building in British Columbia, and beginning on December 15, 2017, “...local governments regulated by the BC Building Act and Community Charter (i.e. all but Vancouver) that wish to require higher energy efficiency standards may only reference the Step Code.” The Step Code is a “...performance-based framework, which by definition is a flexible approach to compliance.” There are a “...vast number of potential solutions to compliance,”¹⁹⁶ and performance requirements vary based on

climate zone. Builders may comply with the Step Code in place of NBC 9.36 or the National Energy Code for Buildings.

An example of performance goals for a specific BC climate zone is presented in Table C2b. The step code includes progressive performance requirements related to airtightness, equipment and systems, and building envelope. Discussions that led to the development of the Step Code emphasized the importance of focussing on passive measures for energy use reduction (specifically, measures related to the building envelope).¹⁹⁷ Energy modelling is required to assess performance for each of the steps. Examples of energy conservation measures (ECMs) that may be used to achieve performance targets are provided in Table C2c.

Table C2b: Step Structure and Requirements for Part 9 – Climate Zone 4 Step Level¹⁹⁸

	Energy Modelling	Airtightness	Equipment and Systems	Envelope
Step 1 Enhanced Compliance (BC Building Code Performance)	Required	No target	BCBC is using 9.36.5 OR ERS v15 ref. house (MEUI of 80 kWh/m2/yr is likely, but not required)	Report on TEDI and PTL (TEDI 50 kWh/ m2/yr is likely, but not required)
Step 2 10% Beyond Code	Required	3.0 ACH ₅₀	10% better than ERS v15 ref. house OR MEUI – 60 kWh/m2/yr	TEDI – 45 kWh/m2/yr OR PTL – 35 W/m2
Step 3 20% Beyond Code	Required	2.5 ACH ₅₀	20% better than ERS v15 ref. house OR MEUI – 45 kWh/m2/yr	TEDI – 40 kWh/m2/yr OR PTL – 30 W/m2
Step 4 40% Beyond Code	Required	1.5 ACH ₅₀	40% better than ERS v15 ref. house OR MEUI – 35 kWh/ m2/yr	TEDI – 25 kWh/m2/yr OR PTL – 25 W/m2
Step 5: 50%+ Beyond Code	Required	1.0 ACH ₅₀	MEUI – 25 kWh/m2/yr (no ERS option)	TEDI – 15 kWh/m2/yr OR PTL – 10 W/m2

MEUI: Mechanical Energy Use Intensity
 TEDI: Thermal Energy Demand Intensity
 PTL: Peak Thermal Load

A recent costing study prepared as part of the implementation process for the Energy Step Code reported that, generally, capital cost increments associated with meeting the majority of the Steps were modest for Part 9 buildings. For example, it was estimated that large single-family dwellings (SFD) could reach Step 4 with under 2% increase in capital costs (in BC climate zones 4 through 6). For medium sized SFDs, the incremental cost to reach Step 4 in BC climate zones 4 through 6 was estimated to be under 2%; however, for smaller SFDs, the estimated capital cost increase reached nearly 8% under the same conditions. In colder climate zones, the incremental capital costs associated with meeting Steps 4 and 5 ranged from ~10 to ~30%. The significant increase in capital costs for smaller homes to reach higher Steps led to a recommendation that targets be adjusted based on size of dwelling, and municipalities may even choose to exempt smaller homes from Step Code requirements.¹⁹⁹

Concern was expressed that stringent energy efficiency requirements associated with the Step Code, specifically provisions related to building envelopes and solar gain glazing, may increase the risk of building overheating—an issue that had been assessed as part of the City of Vancouver’s Zero Emissions Building Plan, which included envelope requirements similar to Step 3 in the BC Step Code. Overheating was notably a concern for southwest facing buildings. For Part 3 buildings with no active cooling, it was stated that overheating could be mitigated by a number of passive measures, including:²⁰⁰

- Larger operable windows, allowing adequate natural ventilation,
- Reduced solar heat gain coefficient on windows, and
- External overhangs to provide window shading.

It was further discussed that existing energy modelling tools (specifically HOT2000) are not well suited to assessing the risk of overheating, and that new methodologies should be developed to assess overheating risk.

Table C2c: Energy Conservation Measure (ECM) Options for Meeting Part 9 Step Code Performance Targets²⁰¹

	Options	# of choices
Airtightness ACH	3.5 ACH, 2.5 ACH, 1.5 ACH, 1.0 ACH, 0.6 ACH	5
Wall R-value	R16, R18, R22, R24, R30, R40, R50, R60	6
Under-slab R-value	R0, R11, R15, R20	4
Foundation Wall R-value	R11.3, R17, R20, R25	4
Exposed Floor R-value	R26.5, R29, R35, R40	4
Ceiling/Roof R-value	R40, R50, R60, R70, R80, R100	6
Window Option & U-Value	3 double, 4 triple (U-1.8 to U-0.8)	7
Domestic Hot Water (DHW) System	Electric & gas tank, 2 x tankless, heat pump	5
Drain Water Heat Recovery	None, 30%, 42%, 55%	4
Space Heating	92% & 95% AFUE, combo, CCASHP	4
Ventilation Heat Recovery	None, 60%, 70%, 75% & 84% SRE	5
Total Number of Possible Combinations		129,024,000

Net Zero Energy: A Net Zero Energy (NZE) home produces at least as much energy as it consumes every year.²⁰² In a NZE home, the energy produced is generated on-site and is renewable. Over the course of a year, the energy supplied to the grid balances the energy taken from the grid, which results in net-zero annual energy consumption. Before becoming a NZE home, a house can be considered NZEr (NZE ready). NZEr homes comply with NZE principles, but without having installed the renewables.²⁰³ In 2006, CMHC initiated the Equilibrium program to “...demonstrate the net-zero annual energy target using modelling principles.”²⁰⁴ Designs involved in the program were required to achieve an Energuide Rating System target of 82, with renewable power generating equipment required to reach an Energuide rating system target of 90 (approaching net-zero), and a final goal of Energuide Ratings System 100, considered to be fully net-zero.²⁰⁵

While there is a clear focus on energy efficiency and renewable energy generation in NZE homes, buildings with technologies and building methods related to NZE may experience enhanced thermal comfort and indoor air quality benefits.²⁰⁶ However, as outlined above, discussion related to implementation of high efficiency homes, including NZE, have included consideration for increased risk of overheating.

Habitation Durable program, City of Victoriaville: The City of Victoriaville implemented its Sustainable Housing Grant and Certification Program in 2011. The program offers financial incentives to both homeowners and builders for measures that increase sustainability of homes, including measures related to water and energy consumption, and measures related to providing improved thermal comfort. The program offers different levels of subsidies for both renovations and new construction.

Subsidy levels depend on the number of prescriptive provisions achieved and can lead to three different levels of certification: Bronze (300-395 points), silver (400-495 points), and gold (more than 500 points). Bonus points are awarded to homeowners who also obtain additional certifications for their projects, such as LEED and Novoclimat 2.0. In Victoriaville, each level of certification is associated with a financial assistance grant provided by the City, which ranges between \$3,000 for bronze certification to \$8,000 for gold certification. Once a project is completed, supporting documents detailing each measure included in the home construction or renovation must be presented to the City to prove compliance. When a financial assistance grant is approved, 10% of the amount is given to the builder or contractor who helped prepare the compliance file for the City.

Several building components are accounted for in the *Habitation Durable* program. These components include insulation levels, airtightness, hurricane ties, and reflective roofs. Each category of intervention (e.g. heating, ventilation, foundation, roofing, etc.) provides different options to the homeowners and builders, each associated with a specific amount of points. Examples of prescriptive measures included in the Victoriaville program are presented in Table C2d.

While the program counts 144 optional requirements, thirteen requirements have recently been made mandatory by City Council and need to be included in all new construction. Examples of mandatory measures include:

- Minimum roof insulation value of R-51,

- Minimum exterior wall insulation value of R-29, and
- Windows and doors certified for ENERGY STAR climate zone 2.

Table C2d: Example of Prescriptive Measures presented in the Victoriaville *Habitation Durable* Program

Category	Provision	Points	Supporting document
Foundation	Slab insulation value of RSI 5.98 (R-34)	15	Plans and specifications, or copies or receipt
Foundation	Foundation walls with an insulation value or RSI 6.16 (R-35)	15	Plans and specifications, or copies or receipt
Frame	Exterior walls with an insulation value or RSI 7.92 (R-45) including RSI 0.7 (R-4) minimum continuous insulation to avoid thermal bridges	15	Plans and specifications, or copies or receipt
Roofing	White roof	10	Copies of receipt
Windows and doors	90% of windows must be certified ENERGY STAR for climate zone 3	20	Copy of contract or copy of receipts
Climate Change Adaptation	Roller shutters are installed outside of windows. These shutters protect windows from extreme weather and overheating. Exterior blinds and shutters have been shown to be more effective at reducing energy loss/gains through windows than interior blinds and related measures, and also serve to reduce likelihood of window condensation.	15	Copies of receipt

Building and sustainability experts from the City of Victoriaville are available to assist homeowners interested in participating in the program by recommending measures that are aligned with the scope of their projects. The program was initially developed by committees of technical experts and has been expanded to seven other municipalities. In Victoriaville alone, the program has resulted in the construction of 376 certified new homes and 838 certified renovation projects.

LEED: Leadership in Energy and Environmental Design (LEED) is a rating program for green buildings. It is a voluntary program that assists building industry professionals with the design, construction, and operation of green buildings and neighbourhoods. The LEED program for New Construction and Major Renovations of commercial buildings was first implemented by the U.S. Green Building Council (USGBC) in 1998 and has since been updated on several occasions. Since the program was initially launched, the USGBC has created LEED programs for other building types, including single-family homes. LEED certified homes are intended to provide several benefits, including reduction in green house gas emissions, energy and water conservation, and more healthful and productive environments for occupants.

Under the LEED system, four different certifications can be reached depending on the amount of points collected: Certified (40-49 points), Bronze (50-59 points), Gold (60-79 points), and Platinum (80 points and above). While the LEED system offers the flexibility to choose which requirements a homeowner or homebuilder will pursue, mandatory measures must be achieved to reach any LEED certification level.

The LEED system awards points under nine categories, including water efficiency, energy and atmosphere, location and transportation, and indoor environmental quality. For three of these categories (water efficiency, energy and atmosphere, and location and transportation), builders have the option to follow either a prescriptive or performance path. For instance, when it comes to envelope performance, the performance path requires that builders prepare an energy model for insulation and air tightness, known as HERS (Home Energy Rating System). Under this system, a HERS reference home would score 100, and a net zero-energy home would score 0. In order to comply with the LEED performance requirements, the HERS ratings of homes must reach ENERGY STAR HERS index targets, which vary depending on the size of the home and number of bedrooms. If builders decide to follow the prescriptive path instead of the performance path, they must follow a single set of measures that will ultimately result in the construction of an ENERGY STAR-certified home. Energy modelling is not required under this approach and contrary to the performance path, builders are not allowed to make any trade-offs under the prescriptive path.

Builders interested in following the prescriptive path must adhere to insulation levels beyond the ones promoted by the IECC (International Energy Conservation Code) 2012. For instance, in order to receive two points, the insulation values provided in Table C2e must be reached.

Table C2e: Increased Insulation Requirements Beyond IECC 2012²⁰⁷

IECC + 20%: 2 Points							
Climate Zone	Ceiling R-value	Wood Frame Wall R-value	Mass Wall R-value	Floor R-value	Basement Wall R-value	Slab R-value and Depth	Crawl Space Wall R-value
1	36	16	4/5**	16	0	0	0
2	46	16	5/7	16	0	0	0
3	46	24 or 16 + 6*	10/16	23	6 cont 16 cavity	0	6 cont 16 cavity
4 except marine	59	24 or 16 + 6	10/16	23	12 cont 16 cavity	12,2 ft (600 mm)	12 cont 16 cavity
5 and marine 4	59	24 or 16 + 6	16/20	36 (3)	18 cont 23 cavity	12,2 ft (600 mm)	18 cont 23 cavity
6	59	24 + 6 or 16 + 12	18/24	36 (3)	18 cont 23 cavity	12,4 ft (1200 mm)	18 cont 23 cavity
7 and 8	59	24 + 6 or 16 + 12	23/25	46 (3)	18 cont 23 cavity	12,4 ft (1200 mm)	18 cont 23 cavity

*For wood frame wall R-value, the first value is cavity insulation, the second is continuous insulation.

**For wood framed wall R-value and mass wall R-value, the second R-value applies when more than half this insulation is on the interior of the mass wall.

Passive House: The Passive House certification aims to reduce energy demand of residential buildings. It is a voluntary certification program managed by the PassivHaus Institute in Germany. Passive homes follow a design and building standard for building envelopes and heating and cooling systems. Passive homes have the potential to achieve 80-90% energy savings.²⁰⁸ While Passive House buildings are held up to higher performance standards than traditional construction, the concept itself is flexible and can be adapted to several types of buildings. To date, more than 40,000 homes worldwide have been built to the passive house standard. Table C2f outlines requirements for Passive House certification.

Table C2f: Criteria to follow to receive the Passive House certification²⁰⁹

Space Heating Demand	Not to exceed 15kWh annually OR 10W (peak demand) per square metre of usable living space.
Space Cooling Demand	Roughly matches the heat demand with an additional, climate-dependent allowance for dehumidification.
Primary Energy Demand	Not to exceed 120kWh annually for all domestic applications (heating, cooling, hot water and domestic electricity) per square meter of usable living space.
Air Tightness	Maximum of 0.6 air changes per hour at 50 Pascals pressure (as verified with an onsite pressure test in both pressurised and depressurised states).
Thermal Comfort	Thermal comfort must be met for all living areas year-round with not more than 10% of the hours in any given year over 25°C*.

NRCC Study on Building Overheating Risk: In late 2017, the National Research Council of Canada (NRCC) was developing a project entitled “Assessing Effect of Overheating of Buildings Arising from Changing Climate Loads.” A collaborative research project between Ottawa Health Science, Health Canada, NRCC and *Institut national de santé publique du Québec*, the project was being designed to provide new information related to overheating risk of a variety of building types under changing climate conditions. Study components are outlined in Table C2g. At the time of writing, the NRCC was seeking local case study participants.

Table C2g: NRCC Building Overheating Study Components

Hazards evaluation	<ul style="list-style-type: none"> • Modelling to determine urban microclimate for specific locations. • Use of model to understand changes in air and surface temperatures, wind and shading associated with different configurations of greenspace. • Understanding influence of urban landscape under different climate scenarios. • Understanding hazard given location of specific buildings.
Degree of exposure to overheating	<ul style="list-style-type: none"> • Understanding factors related to type of building, urban location, construction, orientation, size and configuration. • Measurement campaigns of indoor conditions combined with thermal modelling of whole buildings.
Vulnerability assessment	<ul style="list-style-type: none"> • Development of vulnerability index based on human physiological response to effects of overheating resulting from changing climate conditions. • Establishment of a comfort acceptability range. • Potential consideration of behavioural adaptation of building occupants to risk of overheated building (including closing blinds, reducing movement).
Decision support tool for overheating assessment	<ul style="list-style-type: none"> • Development of GIS decision support system (DSS). • GIS DSS to provide capability for assessing future urban climate and response of building occupants to adaptation measures at the building, neighbourhood and city scales. • Development of case studies to determine effectiveness of measures for reducing overheating effects for given building construction, orientation, glazing type and coverage. • Development of simulations to assess effectiveness of a variety of risk reduction measures, including wall and roof insulation, dynamic windows, internal and external shading devices, cool and/or green roofs.

Definitions

Backfill: Material used to refill an excavated area (e.g., pipe trench, foundation excavation).

Backwater valve: Check valve installed in gravity drainage system for the purposes of reducing risk of sewer backflow entering buildings or drainage systems.²¹⁰

Building sewer: Underground storm or sanitary sewer drainage pipe that conducts sewage from the building to a public storm or sanitary sewer or private sewage disposal system (e.g., septic system).²¹¹ Commonly referred to as storm lateral or sanitary lateral.

Dampproofing: Typically a coating that serves to isolate water absorbing materials.²¹²

Drainage Layer: An initial surface that drains water along the soil/wall interface, combined with airspace between the soil and foundation wall (typically created using dimpled, semi-rigid membrane or fibrous/granular material). These systems direct subsurface water to foundation drainage systems, while airspaces reduce risk that water will be forced into the building envelope as a result of build up of hydrostatic pressure.²¹³

Foundation Drain: Underground drainage system designed to intercept and convey subsurface water.²¹⁴

Foundation Drain Collector (FDC): An underground public sewer system that is designed to collect discharge from foundation drainage systems only.

Impervious: Resistant to the penetration or infiltration of water.

Inflow/infiltration (I/I): Inflow includes sources of direct flow of excess water into sanitary sewer systems, including downspout connections, leakage through manhole covers. Infiltration includes indirect sources of excess water entering sanitary sewer systems, including pipe defects, loose joints, cracks, etc. and is influenced by the height of the groundwater table.

Low Impact Development (LID) Feature: A system that mimics natural processes that result in infiltration, evapotranspiration or use of stormwater.²¹⁵

Roof-to-Wall Connection (RTWC): Connection point between roof rafters, joists and/or trusses and wall framing.

Sewage Ejector: An electric, automatic pump designed to discharge sanitary sewage from fixtures that do not drain by gravity to a public sanitary sewer or private sewage disposal system.

Solar Reflectance Index: A measure of the constructed surface's ability to reflect solar radiation and emit thermal radiation. Note that a standard black surface (initial solar reflectance 0.05, initial thermal emittance 0.90) has an initial SRI of 0, and a standard white surface (initial solar reflectance 0.80, initial thermal emittance 0.90) has an initial SRI of 100. To calculate the SRI for a given material, obtain its solar reflectance and thermal emittance values from the Cool Roof Rating Council Standard (CRRC-1). Calculation of the aged SRI is based on the aged tested values of solar reflectance and thermal emittance. SRI is calculated according to ASTM E 1980.²¹⁶

Solar Reflectance: The ratio of reflected light to incident light.

Solar Emittance: A material's ability to release heat through radiation.

Solar Heat Gain Coefficient (SHGC): Defined as the "...fraction of incident solar radiation admitted through a window, both directly transmitted and absorbed and subsequently released inward." The SHGC is expressed as a number between 0 and 1. A lower SHGC indicates that the window transmits less solar heat.²¹⁷

Utility Penetration: A penetration made in foundation wall/building envelope for utility connections (e.g., hydro, gas).

Waterproofing: A full, continuous barrier to water penetration.²¹⁸

References and End Notes

- ¹ Region of Durham. 2015. Durham Regional Official Plan. Whitby: Durham Region.
- Statistics Canada. 2016. Community Profiles: Durham Region. Ottawa: Statistics Canada.
- ² Sandink, D., Kovacs, P., Oulahan, G., and Shrubsole, D. 2016. Public Relief and Insurance for Residential Flood Losses in Canada: Current Status and Commentary. *Canadian Water Resources Journal*. 41(1-2), 220-237. DOI: 10.1080/07011784.2015.1040458
- ³ For examples of significant loss events, see Insurance Bureau of Canada. 2017. Facts of the Property and Casualty Insurance Industry in Canada. Toronto: Insurance Bureau of Canada.
- ⁴ Insurance Bureau of Canada. 2017. Facts of the Property and Casualty Insurance Industry in Canada. Toronto: Insurance Bureau of Canada.
- ⁵ Insurance Bureau of Canada. 2017. Facts of the Property and Casualty Insurance Industry in Canada. Toronto: Insurance Bureau of Canada.
- ⁶ Personal property sewer backup losses. Source: CatIQ, 2017.
- ⁷ Ahern, M., Kovacs, S., Wilkinson, P., Few, R., and Matthies, F. 2005. Global health impacts of floods: Epidemiologic evidence. *Epidemiologic Reviews*, 27, 36-46.
- Kesik, T., and Seymour, K. 2004. Research Highlight: Practical Measures for the Prevention of Basement Flooding Due to Municipal Sewer Surcharge. Technical Series 04-104. Ottawa: Canada Mortgage and Housing Corporation.
- Taylor, J., man Lai, K., Davies, M., Clifton, D., Ridley, I., and Biddulph, P. 2011. Flood management: Prediction of microbial contamination in large-scale floods in urban environments. *Environment International*, 37, 1019-1029.
- Water Environment Research Foundation (WERF). 2006. Methods for Cost-Effective Rehabilitation of Private Sewer Laterals. WERF: Alexandria, VA.
- Health risks associated with sewer backup are further outlined by these public health authorities:
- The City of Toronto
(<http://www1.toronto.ca/wps/portal/contentonly?vgnextoid=d20b7c6a9967f310VgnVCM1000071d60f89RCRD&vgnnextchannel=f041ffa6ee33f310VgnVCM1000071d60f89RCRD>)
 - Region of Peel (<http://www.peelregion.ca/pw/water/sewage-trtmt/basement-flooding.htm>)
 - Colorado Department of Public Health and Environment (https://www.colorado.gov/pacific/sites/default/files/OEPR_Cleanup-after-residential-sanitary-sewer-backups.pdf)
 - City of Vancouver (<http://vancouver.ca/home-property-development/problems-with-leaks-floods-and-sewage.aspx>)
 - City of Ottawa (<http://ottawa.ca/en/residents/water-and-environment/sewers-and-septic-systems/what-do-if-your-sewer-backs-or-your>)
 - Niagara County Health Department (<http://www.niagaracounty.com/health/Press-Releases/ArtMID/1867/ArticleID/235/Public-Health-Director-Advises-of-Flooding-Health-Risks-and-Prevention>)
 - Saanich Engineering and Public Works (<http://www.saanich.ca/services/utilities/documents/EmergencyAssistanceBrochure--FloodingDrainageandSewerBackupBrochure2012.pdf>)
 - US Environmental Protection Agency (<http://water.epa.gov/polwaste/npdes/sso/>)
 - Government of Manitoba (http://www.gov.mb.ca/asset_library/en/spring_outlook/floodwater_and_your_health.pdf)
 - City of London (<https://www.london.ca/residents/Sewers-Flooding/PDC/Documents/Sewer-Backup.pdf>)
 - Public Health Agency of Canada (<http://www.phac-aspc.gc.ca/hp-ps/eph-esp/fs-fi-d-eng.php>)
- ⁸ Nimmrichter, P., Tariq, A., and Zimmer, C. 2017. Infrastructure Buildings Adaptation State of Play. Prepared for Canada's Adaptation Platform Infrastructure and Buildings Working Group, Co-Chaired by the Institute for Catastrophic Loss Reduction and Engineers Canada.
- Sandink, D. 2015. Urban Flooding and Ground-Related Homes in Canada: An Overview. *Journal of Flood Risk Management*, 9(3), 208-223. DOI: 10.1111/jfr3.12168
- ⁹ Kesik, T. 2015. Best Practices Guide: Management of Inflow and Infiltration in New Urban Developments. Toronto: Institute for Catastrophic Loss Reduction.
- Robinson, B., D'Amico, R., Motala, I., Sandink, D., and Hill, C. 2016. We Need to Address I/I in New Subdivisions Immediately! WEAO 2016 Technical Conference, Niagara Falls, Ontario.
- ¹⁰ Inflow includes sources of direct flow of excess water into sanitary sewer systems, including downspout connections, leakage through manhole covers. Infiltration includes indirect sources of excess water entering sanitary sewer systems, including pipe defects, loose joints, cracks, etc. and is influenced by the height of the groundwater table. During SDHI rainfall events, inflow/infiltration may result in overloading and surcharge of sanitary sewer systems, causing sanitary sewer backup.
- ¹¹ In the context of riverine and coastal flooding, where building may be expected to experience relatively deep floodwaters: "Dry floodproofing is...not recommended for structures with a basement. These types of structures can be susceptible to significant lateral and uplift (buoyancy) forces. Dry floodproofing may not be appropriate for a wood-frame superstructure.... Weaker construction materials, such as wood-frame superstructure with siding, will often fail at much lower water depths from hydrostatic forces." Source: Federal Emergency Management Agency. (2012). Engineering Principles and Practices for Retrofitting Flood-Prone Residential Structures. Washington, D.C.: Federal Emergency Management Agency. Also, see CIRIA. 2005. Standards for the repair of buildings following flooding. London, UK: CIRIA.
- ¹² Exceptions include sealing of utility penetrations, close-to-grade overland flood entry points, and sealing foundation/basement floor cracks.
- ¹³ See Federal Emergency Management Agency. 2012. Engineering Principles and Practices for Retrofitting Flood-Prone Residential Structures. Washington, D.C.: Federal Emergency Management Agency; CIRIA. 2005. Standards for the repair of buildings following flooding. London, UK: CIRIA.
- ¹⁴ See OBC 7.4.6.1. Separate Systems (1) No vertical soil or waste pipe shall conduct both sanitary sewage and storm sewage; and 7.1.5.1. Sanitary Drainage Systems (2) A combined building drain or combined building sewer shall not be installed.
- ¹⁵ 7.4.5.3. Connection of Subsoil Drainage Pipe to a Sanitary Drainage System
- (1) Except as permitted in Sentence (2), no foundation drain or subsoil drainage pipe shall connect to a sanitary drainage system.
- (2) Where a storm drainage system is not available or soil conditions prevent drainage to a culvert or dry well, a foundation drain or subsoil drainage pipe may connect to a sanitary drainage system.

(3) Where a subsoil drainage pipe may be connected to a sanitary drainage system, the connection shall be made on the upstream side of a trap with a cleanout or a trapped sump.

¹⁶ Region of Durham. By-Law #55-2013. Page 5.

¹⁷ Region of Durham. By-law 41 (2009), referenced in the Sewer Use Bylaw.

¹⁸ See OBC 9.13.2 Dampproofing and 9.13.3 Waterproofing

¹⁹ Swinton, M., and Kesik, T. 2005. Performance Guidelines for Basement Envelope Systems and Materials: Final Research Report. Ottawa: Institute for Research in Construction, National Research Council Canada.

²⁰ OBC 9.14.6.1. Surface Drainage (1) The *building* shall be located or the *building* site graded so that water will not accumulate at or near the *building* and will not adversely affect adjacent properties.

²¹ Township of Scugog By-law 16-15 sentence 2.05(2) states “Water from roof runoff or a sump shall not be discharged or allowed to migrate onto sidewalks, stairs, highways or onto any adjacent Property except where approved by the Township of Scugog.”

Town of Whitby Design Criteria Subsection D5.02 sentence (d) states that grading consultants are required to “...show the location of downspouts, splash pads, area drains, and discharge from sump pumps, window wells, walkouts, etc. for both the infill and houses on adjacent lots”

City of Oshawa Engineering Design Criteria Manual 5.5.2 states “Rainfall leaders shall not discharge directly on a driveway.”

²² OBC 9.14.6.4. (1) Where runoff water from a driveway is likely to accumulate or enter a garage, a catch basin shall be installed to provide adequate drainage.

²³ See for example:

<http://www2.markham.ca/markham/ccbs/indexfile/Agendas/2012/Planning%20Public/ds120327/Reverse%20Slope%20Presentation.PDF>

²⁴ City of Pickering. Engineering Design Criteria: Lot–Grading Plans. Sentence 22 states “...reverse driveways sloping towards the garage are not permitted.”

Township of Uxbridge. 2016. Design Criteria. Sentence B.02 states “...the use of negative grade driveways is actively discouraged. Negative sloping driveways will only be considered in estate residential developments under special circumstances. Where negative sloping driveways are used, a positive slope of at least 2.5 percent must be maintained from the garage over a minimum distance of 10.0 metres.”

²⁵ OBC 9.12.3.2. Grading of Backfill states “backfill shall be graded to prevent drainage towards the *foundation* after settling.”

²⁶ Swinton, M., and Kesik, T. 2008. Site Grading and Drainage to Achieve High-Performance Basements. Construction Technology Update No. 69. Ottawa: National Research Council.

²⁷ Local authorities (e.g. municipalities) may need to ensure that they have appropriate jurisdiction to secure easements for rear-yard catch basins, which may require reviewing historical municipal council decisions related to this topic.

²⁸ See OBC 9.14.2 Foundation Drainage

²⁹ See 9.26.18.2. Downspouts, which states “where downspouts are provided and are not connected to a sewer, extensions shall be provided to carry rainwater away from the *building* in a manner that will prevent *soil* erosion.”

³⁰ City of Moncton. n.d. The Homeowner’s Guide to Flood Protection. City of Moncton.

³¹ City of Winnipeg. 2001. Sump Pits & Pumps. The Winnipeg Building By-Law no. 4555/87. Winnipeg: City of Winnipeg.

³² City of Lethbridge. Sump design criteria. <http://www.lethbridge.ca/living-here/water-wastewater/Documents/SumpDesignCriteria.pdf>

³³ City of Winnipeg. 2001. Sump Pits & Pumps. The Winnipeg Building By-Law no. 4555/87. Winnipeg: City of Winnipeg.

³⁴ Personal Communication, Peter Marra, Director of Public Works, Town of LaSalle, October 26, 2017.

See also: OBC 7.3.4.6. Support for Underground Horizontal Piping (1) Except as provided in Sentence (2), nominally horizontal piping that is underground shall be supported on a base that is firm and continuous under the whole of the pipe. (2) Nominally horizontal piping installed underground that is not supported as described in Sentence (1) may be installed using hangers fixed to a foundation or structural slab provided that the hangers are capable of, (a) keeping the pipe in alignment, and (b) supporting the weight, (i) of the pipe, (ii) its contents, and (iii) the fill over the pipe.

³⁵ City of Hamilton. 2013. Binbrook Sanitary and Stormwater Systems Performance. City of Hamilton.

³⁶ City of Toronto. 2008. Update on the Engineering Review Addressing Basement Flooding. Staff Report to Council. August 18, 2008.

Genivar & Clarifica. 2008. Investigation of chronic basement flooding: Sewershed Area 28. Toronto: City of Toronto.

Stantec. 2008. Sewershed area 29 chronic basement flooding class EA. Toronto: City of Toronto.

XCG Consultants Ltd. 2008. Flood remediation plan, environmental assessment project file report: Sewershed study area 30. Toronto: City of Toronto

³⁷ City of Mississauga. 2012. Cooksville Creek Flooding Information.

³⁸ Sandink, D. 2013. Urban flooding in Canada: Lot-side risk reduction through voluntary retrofit programs, code interpretation and by-laws. Toronto: Institute for Catastrophic Loss Reduction.

³⁹ City of Toronto. 2008. Update on the Engineering Review Addressing Basement Flooding. Staff Report to Council. August 18, 2008. Page 5.

⁴⁰ Flow monitoring data was attained for 35 new subdivisions in southern Ontario. Thirty-four of these subdivisions were displaying unacceptably high rates of I/I. Robinson, B. et al. 2017. Project to Address Unacceptable Inflow and Infiltration (I/I) in New Subdivisions. Phase 1 final report (2015-2017). Norton Engineering Inc., York Region, City of London, City of Windsor, Institute for Catastrophic Loss Reduction and Region of Peel; Robinson, B., D’Amico, R., Motala, I., Sandink, D., Hill, C. 2016. We Need to Address I/I in New Subdivisions Immediately! WEAO 2016 Technical Conference, Niagara Falls, Ontario.

⁴¹ Robinson, B., D’Amico, R., Motala, I., Sandink, D., Hill, C. 2016. We Need to Address I/I in New Subdivisions Immediately! WEAO 2016 Technical Conference, Niagara Falls, Ontario.

Robinson, B. et al. 2017. Project to Address Unacceptable Inflow and Infiltration (I/I) in New Subdivisions. Phase 1 final report (2015-2017). Norton Engineering Inc., York Region, City of London, City of Windsor, Institute for Catastrophic Loss Reduction and Region of Peel.

⁴² Robinson, B. et al. 2017. Project to Address Unacceptable Inflow and Infiltration (I/I) in New Subdivisions. Phase 1 final report (2015-2017). Norton Engineering Inc., York Region, City of London, City of Windsor, Institute for Catastrophic Loss Reduction and Region of Peel.

⁴³ Instances of severed connections underneath basement floor slabs, which are very expensive to fix and can lead to poor foundation drainage issues. Further, downpipes that connect sump pumps to municipal storm systems may become disconnected, cracked or may have been unglued, causing water saturation under the basement floor slab. It was noted that downspout connections to storm PDCs are often not inspected. Personal Communication, 2017, Claudio Zicarelli, Flood Prevention Advisor, Edmonton.

⁴⁴ Adapted from Robinson, B. et al. 2017. Project to Address Unacceptable Inflow and Infiltration (I/I) in New Subdivisions. Phase 1 final report (2015-2017). Norton Engineering Inc., York Region, City of London, City of Windsor, Institute for Catastrophic Loss Reduction and Region of Peel.

⁴⁵ Swinton, M., & Kesik, T. 2008. Site grading and drainage to achieve high-performance basements. Construction Technology Update No. 69. Ottawa: National Research Council.

⁴⁶ Swinton, M., & Kesik, T. 2008. Site grading and drainage to achieve high-performance basements. Construction Technology Update No. 69. Ottawa: National Research Council.

⁴⁷ Sandink, D. 2009. Urban flooding, homeowner hazard perceptions and climate change. *Public Sector Digest*, Winter 2009.

⁴⁸ Kovacs, P., Guilbault, S., & Sandink, D. 2014. *Cities Adapt to Extreme Rainfall*. Toronto: Institute for Catastrophic Loss Reduction.

City of Hamilton. 2011. Lot grading policy, criteria and standards for single and semi detached dwelling units created through development applications. Hamilton: City of Hamilton.

⁴⁹ Sentence 10.5.80.40(2) of the City of Toronto Zoning By-Law 569-2013 states: “In the Residential Zone category, for a detached house or semi-detached house, and for an individual townhouse dwelling unit where an individual private driveway leads directly to the dwelling unit, the elevation of the lowest point of a vehicle entrance in a main wall of the building must be higher than the elevation of the centreline of the driveway at the point where it intersects a lot line abutting a street.”

Sentence 4.1.4.(g)(i) of the City of Vaughan’s Zoning By-Law 1-88 (Comprehensive Zoning By-Law) (2012) states that “all driveways shall have a positive slope away from all parts of the building or structure to the street for all single family detached dwellings, semi-detached dwellings townhouse dwelling, and street townhouse dwellings.” Also see City of Vaughan. (2016). City of Vaughan Urban Design Guidelines for Infill Development in Established Low-Rise Residential Neighbourhoods (Draft). Vaughan: City of Vaughan.

⁵⁰ Source: Swinton, M., & Kesik, T. 2008. Site grading and drainage to achieve high-performance basements. Construction Technology Update No. 69. Ottawa: National Research Council.

⁵¹ It should be noted that even well drained window wells can lead to overloading of drainage systems, for example, when window wells are drained via a home’s foundation drainage system (source: Swinton and Kesik, 2008).

⁵² Swinton, M., and Kesik, T. 2005. Performance Guidelines for Basement Envelope Systems and Materials: Final Research Report. Ottawa: Institute for Research in Construction, National Research Council Canada.

⁵³ Swinton, M., & Kesik, T. 2008. Site grading and drainage to achieve high-performance basements. Construction Technology Update No. 69. Ottawa: National Research Council.

⁵⁴ 9.9.10.1. Egress Windows or Doors for Bedrooms (7) Where a protective enclosure is installed over the window well referred to in Sentence (5), such enclosure shall be openable from the inside without the use of keys, tools or special knowledge of the opening mechanism.

⁵⁵ For more detail see: Alberta Safety Codes Council. 2013. STANDATA Building Code Bulletin 06-BCB-010: Disaster Recovery Program – Flood Mitigation Measures for Homes Being Rebuilt. Government of Alberta.

and Swinton, M., and Kesik, T. 2005. Performance Guidelines for Basement Envelope Systems and Materials: Final Research Report. Ottawa: Institute for Research in Construction, National Research Council Canada.

⁵⁶ Note that BNQ 3661-500/2012 largely addresses concerns related to iron ochre. Regardless of the cause of foundation drainage blockage, it is the intent of the standard presented here to increase access to foundation drainage systems for the purposes of inspection and maintenance. BNQ 3661-500/2012 provides options to meet this provision.

In reference to external access chimneys, BNQ 3661-500/2012 further states (Annex A, page 19):

“In spite of all the precautions and the methods applied, the installation of a drainage system in a soil favorable to the clogging of drains always carries a certain risk. In order to prevent this risk, the installation of access or cleaning chimneys connected to the foundation drain is essential.”

“A pressurized water wash will ensure the durability of the building’s storm drainage system. These chimneys consist of two series of 100 mm [4 "] diameter PVC unperforated vertical hoses connected to the drain with elbows and installed at the opposite sides of the building. They terminate at the surface of the ground, where their extremity is provided with a screw-cap. These [chimneys] provide two functions:

- Insert a camera to see the inside of the drain to determine if periodic maintenance is required.
- allow access to the drain for cleaning with pressurized water.

So that runoff water does not provide additional water to the foundation drain, it is preferable that the top layer of the soil be made of impermeable backfill material (such as clay) and set with a slope of 2% , in order to remove the water from the foundation wall. In addition, the downspouts of the gutters can not be connected to or oriented towards the foundation drain; they will end as far as possible from the foundation wall.”

⁵⁷ BNQ 3661-500/2012 further states that (page 18):

“According to the most recent studies carried out on construction sites and in laboratories, ringed flexible drains should be avoided when the land to be constructed presents a risk of clogging by ochre deposits. Although this type of product has experienced recent improvements, particularly with respect to the dimensions of its openings, its annelings and its slit-shaped orifices, favor the accumulation of ferruginous water and restrict the flow of water . Thus, the development of bacteria which occurs inside the drain and which results in the accumulation of consistent deposits (clogging) reduces the hydraulic capacity of the drain (flow).”

“The rigid drain with a smooth wall prevents clogging by other deposits. Its smooth inner wall favors a free flow of ferruginous water and, unlike the ringed drain, does not allow bacteria to proliferate there. Its circular openings allow groundwater to be captured from the water table and effectively routed to the municipal storm sewer system.”

Article 5.2.3.1 of BNQ 3661-500/2012 provides specifications for smooth-walled foundation drainage pipe:

5.2.3 Perforated pipes

Where perforated pipes are used in the works described in this Part, they shall comply with the following requirements.

5.2.3.1 Prior to perforation, the hoses shall meet the following requirements:

- they must comply with the requirements of NQ 3624-130 or CSA B182.1;
- they must have smooth inner and outer walls;
- they must be solid-walled, the pipes with hollow walls not being accepted for the works described in this part;
- they must have a nominal diameter of 100 mm.

5.2.3.2 The hoses shall be perforated and shall have round holes with a diameter of 15 mm ± 2 mm as required in Figure 1. The holes shall be free of burrs which may restrict the flow of liquid.

The sockets must not be drilled. The marking line illustrated in FIG. 1 corresponds to the marking line of the pipe.

NOTE - At the time of publication of this Part, the requirements of NQ 3624-130 do not permit the manufacture of perforated pipes. CSA B182.1 does not permit the manufacture of pipes having an area of opening per meter as large as that required in Figure 1. Fittings must not be drilled.

“Mounting with 45 ° elbows makes inspection and cleaning devices easier to run through the pipe.”

BNQ 3661-500/2012 contains further provisions related to aggregates, backfill composition and drainage membranes suitable for foundation drainage systems exposed to risk associated with iron ochre.

⁵⁸ Specifically, the Ontario Ministry of Municipal Affairs is considering adding a sentence to 7.4.6.4. that states “A *backwater valve* shall be installed either on a *storm drainage pipe*, a *storm building drain* or a *storm building sewer* to protect *fixtures* located within a *building* that are subject to *backflow*.” (Ministry of Municipal Affairs. 2016. Index: Potential Changes to Ontario’s Building Code. CC-B-07-04-01. Toronto: Ministry of Municipal Affairs).

⁵⁹ City of Oshawa. Design Requirements for the Construction of Storm Sewer and Foundation Drain Collector Systems. Section 4.2.1.

⁶⁰ <http://ottawa.ca/en/residents/water-and-environment/wastewater-and-sewers/sewer-backups-and-flooding>

⁶¹ American Society of Mechanical Engineers. 2003. Backwater Valves: An American National Standard. ASME A112.14.1-2003. Reaffirmed 2017.

⁶² UL/ULC Standards. 2016. Standard for Safety. ANSI/CAN/UL/ULC 1201:2016 – Sensor Operated Backwater Prevention Systems.

⁶³ CAN/CSA-1800-15 National Standard of Canada – Thermoplastic non-pressure piping compendium.

⁶⁴ Technical Committee members recommended that water-powered backup sump pumps not be used due to concerns related to water consumption and the potential for installation errors that result in increased risk of backflow into potable water systems.

Note that the City of London’s basement flood protection subsidy program specifically excludes funding for water-powered backup sump pumps (<https://www.london.ca/residents/Sewers-Flooding/Basement-Flooding-Prevention/Pages/Sump-Pump-Grant-Program.aspx>).

⁶⁵ City of Moncton. n.d. The Homeowner’s Guide to Flood Protection. City of Moncton.

⁶⁶ For example, the City of Moncton. (n.d.) and City of Edmonton (2016) state that downspout extensions must end at least 15 cm inside of property lines.

⁶⁷ Considerations for downspout drainage into rain barrels:

- It may be appropriate to discharge downspouts to rain barrels or other receptacles as a means of water conservation,
- It should be noted that rain barrels are not designed to capture large volumes of water, and are not flood risk reduction devices,
- Homeowners must be notified of rain barrel maintenance requirements, including ensuring that rain barrels emptied between storms (on average, once every three days),
- Rain barrels must also be supplied with an overflow pipe of sufficient capacity to ensure that rain barrels do not overflow directly beside foundation walls,
- Rain barrel overflow pipes should be made to discharge at least 1.8 m away from foundation walls, and should be directed to appropriate drainage infrastructure (e.g. drainage swales). Where site/drainage conditions do not permit 1.8 m extensions, at minimum ensure that discharge points beyond the line of excavation and backfill,
- Ensure that rain barrel overflow pipes will not negatively affect neighbouring properties, and
- Overflow discharge pipes should not result in build-up of ice on impermeable surfaces, including public and private walkways, driveways, pedestrian paths, etc.

⁶⁸ At the time of writing, these materials under review. Materials will be available from the following webpage in 2018: https://wiki.sustainabletechnologies.ca/index.php?title=Special:CiteThisPage&page=Main_Page&id=5893

2010 versions of the guidance documents are available from <https://www.creditvalleyca.ca/low-impact-development/low-impact-development-stormwater-management-planning-design-guide/>

- ⁶⁹ American Society of Mechanical Engineers. 2003. Backwater Valves: An American National Standard. ASME A112.14.1-2003. Reaffirmed 2017.
- ⁷⁰ UL/ULC Standards. 2016. Standard for Safety. ANSI/CAN/UL/ULC 1201:2016 – Sensor Operated Backwater Prevention Systems.
- ⁷¹ CAN/CSA-1800-15 National Standard of Canada – Thermoplastic non-pressure piping compendium.
- ⁷² See Ministry of Environment. 2003. Stormwater Planning and Design Manual. Toronto: Ministry of Environment.
- ⁷³ Ministry of Environment. 2003. Stormwater Planning and Design Manual. Toronto: Ministry of Environment. See: <https://www.ontario.ca/document/stormwater-management-planning-and-design-manual/stormwater-management-plan-and-swmp-design>
- ⁷⁴ City of Oshawa Engineering Design Criteria Manual Section 5: Lot Grading, subsection 5.7 states “roof water leaders discharged to the surface shall be directed to front and rear yard permeable areas only and not to the side yard swale.”
- ⁷⁵ At the time of writing, these materials under review. Materials will be available from the following webpage in 2018: https://wiki.sustainabletechnologies.ca/index.php?title=Special:CiteThisPage&page=Main_Page&id=5893

2010 versions of the guidance documents are available from <https://www.creditvalleyca.ca/low-impact-development/low-impact-development-stormwater-management-planning-design-guide/>

- ⁷⁶ Alberta Safety Codes Council. 2013. STANDATA Building Code Bulletin 06-BCB-010: Disaster Recovery Program – Flood Mitigation Measures for Homes Being Rebuilt. Government of Alberta.
- ⁷⁷ Robinson, B. et al. 2017. Project to Address Unacceptable Inflow and Infiltration (I/I) in New Subdivisions. Phase 1 final report (2015-2017). Norton Engineering Inc., York Region, City of London, City of Windsor, Institute for Catastrophic Loss Reduction and Region of Peel.

Further:

“The main culprit of infiltration is mortared or mastic joints and non-gasketed coupler or banded connections. All of these types of joints do not provide a watertight seal or control infiltration. The mortared or mastic joints may initially be watertight, but they cannot accommodate pipe-to-pipe or pipe-to-structure settlement resulting in cracking of this filler material and subsequent leaking. The bands or couplers are or eventually become plastic-to-plastic or metal-to-metal, which prevents creating a watertight seal. The structural integrity of a system can, therefore, only be assured by preventing infiltration, which requires a silt-tight or watertight system.” Source: Kurdziel, J.M. 2002. The evolution of watertight storm drainage systems. American Society of Civil Engineers, Pipelines 2002, Beneath our Feet, Challenges and Solutions.

- ⁷⁸ Tarion. 2013. Construction Performance Guidelines for the Ontario Home Building Industry. Toronto: Tarion.
- ⁷⁹ For measurement methods and additional information, see: Tarion. 2013. Construction Performance Guidelines for the Ontario Home Building Industry. Toronto: Tarion.
- ⁸⁰ Sills, D., Cheng, V., McCarthy, P., Rousseau, B., Waller, J., Elliott, L., Klassen, J., and Auld, H. 2012. Using tornado, lightning and population data to identify tornado prone areas in Canada. 26th Conference on Severe Local Storms, Nashville, TN., American Meteorological Society, Pg. 59.
- ⁸¹ Sills, D., Cheng, V., McCarthy, P., Rousseau, B., Waller, J., Elliott, L., Klassen, J., and Auld, H. 2012. Using tornado, lightning and population data to identify tornado prone areas in Canada. 26th Conference on Severe Local Storms, Nashville, TN., American Meteorological Society, Pg. 59.
- ⁸² Newark, M.J. 1991. A design basis tornado. Canadian Journal of Civil Engineering, 18(3): 521–524. doi:10.1139/I91-063.
- ⁸³ Newark, M.J. 1991. A design basis tornado. Canadian Journal of Civil Engineering, 18(3): 521–524. doi:10.1139/I91-063.
- ⁸⁴ Based on confirmed and probable tornado occurrence between 1980 and 2009 in Canada. Sills, D., Cheng, V., McCarthy, P., Rousseau, B., Waller, J., Elliott, L., Klassen, J., and Auld, H. 2012. Using tornado, lightning and population data to identify tornado prone areas in Canada. 26th Conference on Severe Local Storms, Nashville, TN., American Meteorological Society, Pg. 59.
- ⁸⁵ Oklahoma Uniform Building Code Commission. 748 - Uniform Building Code Commission. Adopted Codes International Residential Code®, 2015 Edition (IRC®, 2015) 748:20-5-1 through 748:20-5-28. Appendix Y. Recommendations made in this section of the building requirements align closely with requirements currently in force in the City of Moore, Oklahoma.
- ⁸⁶ Ramseyer, C., and Holliday, L. 2014. City of Moore: New Building Code for Tornado Resistance. Presentation made to Moore City Council Meeting, February 18, 2014.
- ⁸⁷ Morrison, M.J., Kopp, G., Gavanski, E., Miller, C., and Ashton, A. 2014. Assessment of damage to residential construction from the tornadoes in Vaughan, Ontario, on 20 August 2009. *Canadian Journal of Civil Engineering*, 41, 550-558.
- ⁸⁸ Kopp, G., Hong, E., Gavanski, E., Stedman, D., and Sills, D. 2017. Assessment of wind speeds based on damage observations from the August (Ontario) tornado of 17 June 2014. *Canadian Journal of Civil Engineering*, 44, 37-47.
- ⁸⁹ Morrison, M.J., Kopp, G., Gavanski, E., Miller, C., and Ashton, A. 2014. Assessment of damage to residential construction from the tornadoes in Vaughan, Ontario, on 20 August 2009. *Canadian Journal of Civil Engineering*, 41, 550-558.
- ⁹⁰ Kopp, G., Hong, E., Gavanski, E., Stedman, D., and Sills, D. 2017. Assessment of wind speeds based on damage observations from the August (Ontario) tornado of 17 June 2014. *Canadian Journal of Civil Engineering*, 44, 37-47.
- ⁹¹ <http://www.citynews.ca/2010/08/20/one-year-ago-tornado-touches-down-in-vaughan/>
https://www.thestar.com/news/gta/2009/08/22/residents_pick_up_the_pieces_after_storm.html
- ⁹² Morrison, M.J., Kopp, G., Gavanski, E., Miller, C., and Ashton, A. 2014. Assessment of damage to residential construction from the tornadoes in Vaughan, Ontario, on 20 August 2009. *Canadian Journal of Civil Engineering*, 41, 550-558.
- ⁹³ Morrison, M.J., Kopp, G., Gavanski, E., Miller, C., and Ashton, A. 2014. Assessment of damage to residential construction from the tornadoes in Vaughan, Ontario, on 20 August 2009. *Canadian Journal of Civil Engineering*, 41, 550-558.
- ⁹⁴ Morrison, M., and Kopp, G. 2011. Performance of toe-nail connections under realistic wind loading. *Engineering Structures*, 33(1), 69-76.
- ⁹⁵ Nateghi, A.F. 1996. Assessment of wind speeds that damage buildings. *Natural Hazards*, 14, 73-84.
- ⁹⁶ Kopp, G., Hong, E., Gavanski, E., Stedman, D., and Sills, D. 2017. Assessment of wind speeds based on damage observations from the August (Ontario) tornado of 17 June 2014. *Canadian Journal of Civil Engineering*, 44, 37-47. pg. 39

⁹⁶ Morrison, M.J., Kopp, G., Gavanski, E., Miller, C., and Ashton, A. 2014. Assessment of damage to residential construction from the tornadoes in Vaughan, Ontario, on 20 August 2009. *Canadian Journal of Civil Engineering*, 41, 550-558.

⁹⁷ Kopp, G. 2009. Damage observations from the Vaughan tornadoes of August, 20 2009. Presentation to Institute for Catastrophic Loss Reduction. September, 2009.

Kopp, G. 2008. Full-scale testing at the insurance research lab for better homes. Presentation to Institute for Catastrophic Loss Reduction. September, 2008.

⁹⁸ Allen 1992, 1986, 1984; Carter et al. 1989 cited in Cheng, V. Y., Arhonditsis, G. B., Sills, D. M., Auld, H., Shephard, M. W., Gough, W. A., & Klaassen, J. (2013). Probability of tornado occurrence across Canada. *Journal of Climate*, 26(23), 9415-9428. Pg. 9415.

⁹⁹ See OBC 9.23.6.1. Anchorage of Building Frames.

¹⁰⁰ Higher wind speeds (i.e. degree-of-damage upper bound limits for degree-of-damage 4 and 6) are required to result in uplift of hip roof deck and removal of sections of hip roofs. Kopp et al. 2017 also observed that hip roofs require median 50 km/h faster wind speeds for failure, when compared to gable roofs – the equivalent of moving up one category in the EF scale.

¹⁰¹ For more information, see:

Institute for Catastrophic Loss Reduction. (2016). Protect your home from earthquakes. Toronto: ICLR.

Institute for Catastrophic Loss Reduction. (2012). Protect your home from severe wind. Toronto: ICLR.

Institute for Catastrophic Loss Reduction. (2012). Protect your home from snow and ice storms. Toronto: ICLR.

¹⁰² See City of Moore, OK. 2014. High wind resistance residential construction requirements. Moore, OK: City of Moore.

¹⁰³ Adapted from City of Moore, OK. 2014. High wind resistance residential construction requirements. Moore, OK: City of Moore. Ramseyer, C., and Holliday, L. 2014. City of Moore: New Building Code for Tornado Resistance. Presentation made to Moore City Council Meeting, February 18, 2014.

¹⁰⁴ Higher wind speeds (i.e. degree-of-damage upper bound limits for degree-of-damage 4 and 6) are required to result in uplift of hip roof deck and removal of sections of hip roofs. Kopp et al. 2017 also observed that hip roofs require median 50 km/h faster wind speeds for failure, when compared to gable roofs – the equivalent of moving up one category in the EF scale.

¹⁰⁵ Available from: <https://www.floridadisaster.org/hrg/content/roofs/bracing.asp>

¹⁰⁶ Adapted from PROPOSED CHANGE TO THE 2012 BUILDING CODE O. Reg. 332/12 as Amended. Code Change number 2-CC-B-09-23-01. Code reference: Div. B, 9.23.3.4.

¹⁰⁷ Morrison, M., and Kopp, G. 2011. Performance of toe-nail connections under realistic wind loading. *Engineering Structures*, 33(1), 69-76.

¹⁰⁸ The code change request noted above specifically stated that:

Roof rafter, roof truss or roof joist shall be tied to *loadbearing* walls framing with engineered connectors that will resist a factored uplift load of 3 kN...

...Galvanized-steel straps are deemed to comply with [above sentence], provided they are:

- (a) 50 mm wide,
- (b) not less than 0.91 mm thick, and
- (c) fastened at each end with at least four 63 mm nails.

A-9.23.3.4.(3) Establishing uplift resistance: The factored uplift resistance shall be established using general guidance laid out in Section 12.10 “Joist Hangers” of CSA O86 “Engineering Design in Wood”, as applicable to engineered roof-to-wall tie-down engineered connectors in lieu of specific procedures for those products.

¹⁰⁹ Henderson, D., Williams, C., Gavanski, E., and Kopp, G. 2013. Failure mechanisms of roof sheathing under fluctuating wind loads. *Journal of Wind Engineering and Industrial Aerodynamics*, 114, 27-37.

¹¹⁰ Sparks, P.R., Schiff, S.D., and Reinhold, T.A. 1994. Wind damage to envelopes of houses and consequent insurance losses. *Journal of Wind Engineering and Industrial Aerodynamics*, 53(1-2), 145-155.

¹¹¹ Canadian Wood Council. 2014. Engineering Guide for Wood Frame Construction. 2014 Edition. Ottawa: Canadian Wood Council. page B-19: “Note: A 2-3 mm gap (the same size as a typical sheathing nail diameter) between all panel edge and end joints is required to minimize the potential for panel buckling due to wood sheathing’s moisture related expansion and shrinkage. This gap can be sealed appropriately to form an air barrier.”

¹¹² Adapted from City of Moore, OK. 2014. High wind resistance residential construction requirements. Moore, OK: City of Moore.

¹¹³ Specifically, 9.23.10.2. Bracing and Lateral Support, sentence 2 states: Bracing is not required where the walls (a) have an interior finish conforming to the requirements of Section 9.29, or (b) where the walls are, (i) clad with panel-type siding, (ii) diagonally sheathed with lumber, or (iii) sheathed with plywood, OSB, waferboard, gypsum or fibreboard sheathing. Thus, a requirement for OSB or plywood sheathing exceeds current OBC requirements.

OBC 9.23.10.2. Bracing and Lateral Support

(1) Except as provided in Sentence (2), each exterior wall in each storey shall be braced with at least one diagonal brace conforming to Sentence (3).

(2) Bracing is not required where the walls,

- (a) have an interior finish conforming to the requirements of Section 9.29., or
- (b) where the walls are,
 - (i) clad with panel-type siding,
 - (ii) diagonally sheathed with lumber, or
 - (iii) sheathed with plywood, OSB, waferboard, gypsum or fibreboard sheathing.

(3) Where bracing is required, it shall,

- (a) consist of not less than 19 mm by 89 mm wood members,
- (b) be applied to the studs at an angle of approximately 45° to the horizontal, and
- (c) extend the full height of the wall on each storey.

(4) Bracing described in Sentence (3) shall be nailed to each stud and wall plate by at least two 63 mm nails.

(5) Where *loadbearing* interior walls are not finished in accordance with Sentence (2), blocking or strapping shall be fastened to the studs at mid-height to prevent sideways buckling.

¹¹⁴ Henderson ,D., Williams, C., Gavanski, E., and Kopp, G. 2013. Failure mechanisms of roof sheathing under fluctuating wind loads. *Journal of Wind Engineering and Industrial Aerodynamics*, 114, 27-37.

¹¹⁵ Adapted from City of Moore, OK. 2014. High wind resistance residential construction requirements. Moore, OK: City of Moore.

¹¹⁶ See 10.4.2.(c), and detail in Figure for gap width (3 mm) recommendation in Canadian Wood Council. 2014. Engineering Guide for Wood Frame Construction. 2014 Edition. Ottawa: Canadian Wood Council.

¹¹⁷ Adapted from City of Moore, OK. 2014. High wind resistance residential construction requirements. Moore, OK: City of Moore.

¹¹⁸ Adapted from City of Moore, OK. 2014. High wind resistance residential construction requirements. Moore, OK: City of Moore.

¹¹⁹ 9.23.6.2. Anchorage of Columns and Posts

(1) Except as provided in Sentences (2) and (3), exterior columns and posts shall be anchored to resist uplift and lateral movement.

(2) Except as provided in Sentence (3), where columns or posts support balconies, decks, verandas and other exterior platforms, and the columns or posts extend not more than 600 mm above finished ground level, the supported joists or beams shall be,

(a) anchored to a *foundation* to resist uplift and lateral movement, or

(b) directly anchored to the ground to resist uplift.

(3) Anchorage is not required for platforms described in Sentence (2) that,

(a) are not more than 1 *storey*,

(b) are not more than 55 m² in area,

(c) do not support a roof, and

(d) are not attached to another structure, unless it can be demonstrated that differential movement will not adversely affect the performance of that structure.

¹²⁰ OBC reference: 9.35.4.3. Anchorage (1) Garage or carport walls and columns shall be anchored to the *foundation* to resist wind uplift in conformance with Subsection 9.23.6., except that where a garage is supported on the surface of the ground, ground anchors shall be provided to resist wind uplift.

¹²¹ Additional justification and detail for this recommendation:

Uplift forces applied to porch roofs and raised decks during design winds conditions can cause support posts to be lifted off of their supports causing structural damage to the building. The anchoring requirements are not currently provided in a prescriptive format leading to inadequately anchored installations in the field.

By adequately attaching porch roof support beams to their posts, and posts to their foundation, the resistance of the posts to uplift forces during windstorms is increased, decreasing the risk of structural damage.

The design uplift force on trusses can be calculated using the Static Procedure defined in Commentary I of the code as follows:

Assuming a house with the following characteristics;

- located in lowest 1 in 50 wind exposure locations of 0.3 kPa (Dryden ON),
- 2.44 m (8') wide porch,
- 2.44 m (8') between posts,
- porch weighs 0.48 kPa (10 psf), and
- open terrain wind exposure,

results in an external uplift force of 1.8 kN per column. Hence, relying on the weight of the porch roof is inadequate and a fastener is needed to anchor the bottom and top of the column to resist uplift forces for all locations in Canada. The design wind pressure for low and medium exposure is 0.8 kPa which would result in a 6.8 kN (1536 lb) uplift load. For the highest wind load of 1.05 (Cape Race, NFLD) 9.3 kN (2099 lb) per column would be required.

Currently porch columns are often toe nailed to foundations which provides insufficient uplift capacity.

Note that some of the highest wind load values currently referenced in the OBC are for the east shore of Lake Huron (for example, Port Elgin, 1/50 year hourly wind pressure of 0.55 kPa). This provision would result in application of standards that exceed these values.

¹²² Adapted from City of Moore, OK. 2014. High wind resistance residential construction requirements. Moore, OK: City of Moore.

¹²³ Image and text from Canadian Wood Council. 2014. Engineering Guide for Wood Frame Construction, 2014 ed. Ottawa: CWC. Used with permission.

¹²⁴ Excerpts of images and text from Building Component Safety Information (BCSI) Canada. 2014. Guide to Good Practice for Handling, Installing, Restraining and Bracing of Metal Plate Connected Wood Trusses. Produced by Structural Building Components Association (SBCA), Truss Plate Institute (TPI), and Truss Plate Institute of Canada (TPIC). For more information, visit sbcindustry.com. Used with permission.

¹²⁵ Meel, G, and C. Tebaldi. 2004. More Intense, More Frequent, and Longer Lasting Heat Eaves in the 21st Century. *Science* 305(5686): 994-7.

¹²⁶ ICLEI Canada. 2015. Options for Reducing Risk from Extreme Heat to vulnerable populations living in multi-family residential buildings. Toronto: ICLEI Canada.

¹²⁷ Spacing Toronto. 2016. 40 in the shade: Toronto's worst heatwave. Available from <http://spacing.ca/toronto/2016/07/09/80th-anniversary-torontos-worst-heatwave/>

- ¹²⁸ TVO. 2017. The Silent Threat of Heatwaves. Available from <http://tvo.org/article/current-affairs/climate-watch/the-silent-threat-of-heat-waves>
- ¹²⁹ City of Toronto. 2017. Reducing Vulnerability to Extreme Heat in the Community and at Home. Available from <http://www.toronto.ca/legdocs/mmis/2017/hl/bgrd/backgroundfile-103572.pdf>
- ¹³⁰ Durham Region Health Department. 2016. Population at a Glance. Whitby: Region of Durham. Available from https://www.durham.ca/departments/health/health_statistics/popAtAGlance.pdf
- ¹³¹ Chartered Institution of Building Services Engineers London. 2010. How to Manage Overheating in Buildings. London: CIBSE.
- ¹³² Salagnac, J. 2007. Lessons from the 2003 heat wave: A French perspective. *Building Research & Information*, 35(4), 450-457.
- ¹³³ City of Vancouver. 2008. City of Vancouver Passive Design Toolkit. Prepared by Cobalt Engineering. Vancouver: City of Vancouver.
- ¹³⁴ MMA. 2017. Proposed Change to the 2012 Building Code. Toronto: Ministry of Municipal Affairs. Available from <http://www.mah.gov.on.ca/Page16516.aspx>
- ¹³⁵ Image: Institute for Catastrophic Loss Reduction. Adapted from Gruen Eco Design: The difference between air-leakage and ventilation. <http://gruenecodesign.com.au/the-difference-between-air-leakage-ventilation/>
- ¹³⁶ Brown, G. and DeKay, M. 2001. *Sun, Wind & Light: Architectural Design Strategies* (2nd Ed). John Wiley and Sons. Inc.
- ¹³⁷ Institute for Catastrophic Loss Reduction. Adapted from: Innovative openings: <https://www.innovativeopenings.com/window-security/exterior-rolling-shutters/>; Renson sun protection: <http://www.renson-sunprotection.com/en/product/brise-soleil-and-solar-shading>; Tampa Blinds and shutters: <http://www.tampablindsandshutters.com/exterior-solar-screens-tampa-fl.php>; and JAG Construction Corp. <https://www.jagconstructioncorp.com/porch/>
- ¹³⁸ Durham Region. 2016. Towards Resilience – Durham Community Climate Adaptation Plan. Whitby: Region of Durham. Page 56.
- ¹³⁹ Green Salute. 2016. Cools Buildings. Available from <http://greensulate.com/benefits/save-energy/>
- ¹⁴⁰ U.S. Environmental Protection Agency. 2008. Reducing urban heat islands: Compendium of strategies. Draft. Available from <https://www.epa.gov/heat-islands/heat-island-compendium> (trees and vegetation page 3).
- ¹⁴¹ Durham Region. 2012. From Vision to Action: Region of Durham Community Climate Change Local Action Plan 2012. Whitby: Region of Durham. Page 20.
- ¹⁴² BC Housing et al. 2017. Energy Step Code: Building Beyond the Standard. 2017 Metrics Research Full Report. BC Housing.
- ¹⁴³ See FireSmart Canada. <https://www.firesmartcanada.ca>
- ¹⁴⁴ Brown, N. 2015. Net Zero Nest. Shading Windows & Passive Solar Design. Available from <http://netzeronest.com/shading-windows-passive-solar-design/>
- ¹⁴⁵ Laouadi, A. 2010. Guidelines for effective residential solar shading devices. Ottawa: Indoor Environment Research Program, Institute for Research in Construction, National Research Council
- ¹⁴⁶ McCluney, R. and Jindra, P. n.d. Industry Guide to Selecting the Best Residential Window Options for the Florida Climate. Florida Solar Energy Centre.
- ¹⁴⁷ City of Vancouver. 2008. City of Vancouver Passive Design Toolkit. Prepared by Cobalt Engineering. Vancouver: City of Vancouver.
- ¹⁴⁸ Laouadi, A. 2010. Guidelines for effective residential solar shading devices. Ottawa: Indoor Environment Research Program, Institute for Research in Construction, National Research Council.
- ¹⁴⁹ Brown, G. and DeKay, M. 2001. *Sun, Wind & Light: Architectural Design Strategies* (2nd Ed). John Wiley and Sons. Inc. p. 146-147.
- ¹⁵⁰ CIBSE. 2017. Design Methodology for the Assessment of Overheating Risk in Homes. Londong : CIBSE. Pg. 5. Available from <https://www.cibse.org/knowledge/knowledge-items/detail?id=a0q000000CQ83EQAT>
- ¹⁵¹ CIBSE. 2017. Design Methodology for the Assessment of Overheating Risk in Homes. Londong : CIBSE. Pg. 5. Available from <https://www.cibse.org/knowledge/knowledge-items/detail?id=a0q000000CQ83EQAT>
- ¹⁵² Proposed changes for 2020: “Windows included in SB-12’s prescriptive packages would require a U-value at or below 1.4, the value for a common triple-pane window...currently, the Building Code does not require triple-pane windows and sliding doors as a standard component in new house construction...the Ministry of Municipal Affairs is proposing to require that all new houses be constructed using triple-pane windows and sliding doors.”
- “Adding to the previous round of proposed 2020 improvements, proposed requirements for 2022 include more energy efficient triple-pane windows and sliding doors with a U-value at or below 1.2.”
- MMA. 2017. Potential Changes to Ontario’s Building Code. Toronto: Ministry of Municipal Affairs. Available from: <http://www.mah.gov.on.ca/Page16489.aspx>
- ¹⁵³ Windows Collaborative. 2017. Measuring Performance: Energy Star Windows. Available from <http://www.efficientwindows.org/energystar.php>
- ¹⁵⁴ ENERGY STAR. ENERGY STAR product Specification Residential Windows, Doors, and Skylights. Available from https://www.energystar.gov/sites/default/files/ES_Final_V6_Residential_WDS_Spec.pdfhttps://www.energystar.gov/sites/default/files/ES_Final_V6_Residential_WDS_Spec.pdf
- ¹⁵⁵ Arasteh et al., 2006. Zero Energy Windows. Lawrence Berkeley National Laboratory. Available from <https://escholarship.org/content/qt2zp5m6x8/qt2zp5m6x8.pdf>
- ¹⁵⁶ Image: Institute for Catastrophic Loss Reduction. Input from Technical Committee. Adapted from Your Home: Australia’s guide to environmentally sustainable homes. Passive solar heating. <http://www.yourhome.gov.au/passive-design/passive-solar-heating> and Stock Photo <https://www.dreamstime.com/stock-photos-collection-vector-trees-image8174843>
- ¹⁵⁷ See California Energy Commission. 2008. 2008 Building energy efficiency standards for residential and nonresidential buildings; Urban, B., and Roth, K. 2010. Guidelines for selecting cool roofs. V. 1.2. US Department of Energy.
- ¹⁵⁸ Urban, B., and Roth, K. 2010. Guidelines for selecting cool roofs. V. 1.2. US Department of Energy.
- ¹⁵⁹ Urban, B., and Roth, K. 2010. Guidelines for selecting cool roofs. V. 1.2. US Department of Energy.

- ¹⁶⁰ ENERGY STAR. Roof Products Key Product Criteria. Available from https://www.energystar.gov/products/building_products/roof_products/key_product_criteria
- ¹⁶¹ Personal Communication, December, 2017, Lisa King, Senior Policy Planner, City Planning Division (City of Toronto). This approach is applied for enforcement of the Toronto Green Standard.
- ¹⁶² Image source: Continuing Education Centre Architecture + Construction. Cool Roofs for Hot Projects. Available from <https://continuingeducation.bnppmedia.com/courses/cool-roof-rating-council/cool-roofs-for-hot-projects/2/>
- ¹⁶³ City of Vancouver. 2008. City of Vancouver Passive Design Toolkit. Prepared by Cobalt Engineering. Vancouver: City of Vancouver.
- ¹⁶⁴ U.S. Environmental Protection Agency. 2008. Reducing urban heat islands: Compendium of strategies. Draft. Available from <https://www.epa.gov/heat-islands/heat-island-compendium> (trees and vegetation page 3).
- ¹⁶⁵ U.S. Green Building Council. 2013. LEED Reference Guide for Homes Design and Construction. p.97.
- ¹⁶⁶ U.S. Environmental Protection Agency. 2008. Reducing urban heat islands: Compendium of strategies. Draft. Available from <https://www.epa.gov/heat-islands/heat-island-compendium> (trees and vegetation page 3).
- ¹⁶⁷ See Fire Smart Canada. <https://www.firesmartcanada.ca>
- ¹⁶⁸ City of Toronto. Toronto Green Standard: Making a Sustainable City Happen for New Low-Rise Residential Development Version 2.1. 2017. Available from https://www1.toronto.ca/City%20of%20Toronto/City%20Planning/Developing%20Toronto/Files/pdf/TGS/2017TGS_LowRise_Standard.pdf
- ¹⁶⁹ U.S. Green Building Council, 2013. LEED Reference Guide for Homes Design and Construction. p.97.
- ¹⁷⁰ Personal Communication, December, 2017, Lisa King, Senior Policy Planner, City Planning Division (City of Toronto). This approach is applied for enforcement of the Toronto Green Standard.
- ¹⁷¹ Chandra, S., Fairey, P., and Houston, M. 1986. Cooling with Ventilation. Florida Solar Energy Centre.
- ¹⁷² City of Vancouver. 2008. City of Vancouver Passive Design Toolkit. Prepared by Cobalt Engineering. Vancouver: City of Vancouver.
- U.S. Environmental Protection Agency. 2008. Reducing urban heat islands: Compendium of strategies. Draft. <https://www.epa.gov/heat-islands/heat-island-compendium> (trees and vegetation page 3).
- ¹⁷³ Passive House Institute - see https://passipedia.org/basics/passive_house_checklist
- ¹⁷⁴ U.S. Green Building Council, 2013. LEED Reference Guide for Homes Design and Construction. Page 247.
- ¹⁷⁵ U.S. Environmental Protection Agency. 2008. Reducing urban heat islands: Compendium of strategies. Draft. <https://www.epa.gov/heat-islands/heat-island-compendium> (trees and vegetation page 3).
- ¹⁷⁶ City of Vancouver. 2017. Energy Efficiency Updates to Vancouver’s Building By-law and Related Additional Changes Report. Vancouver: City of Vancouver. Available from <http://council.vancouver.ca/20170207/documents/rr3.pdf>
- ¹⁷⁷ City of Vancouver. 2017. Energy Efficiency Updates to Vancouver’s Building By-law and Related Additional Changes Report. Vancouver: City of Vancouver. Available from <http://council.vancouver.ca/20170207/documents/rr3.pdf>
- ¹⁷⁸ Proposed changes for 2020: “Windows included in SB-12’s prescriptive packages would require a U-value at or below 1.4, the value for a common triple-pane window...currently, the Building Code does not require triple-pane windows and sliding doors as a standard component in new house construction...the Ministry of Municipal Affairs is proposing to require that all new houses be constructed using triple-pane windows and sliding doors.”
- “Adding to the previous round of proposed 2020 improvements, proposed requirements for 2022 include more energy efficient triple-pane windows and sliding doors with a U-value at or below 1.2.”
- MMA. 2017. Potential Changes to Ontario’s Building Code. Toronto: MMA. Available from: <http://www.mah.gov.on.ca/Page16489.aspx>
- ¹⁷⁹ OBC SB-12 2.1.2.1. (5) Except as provided in Sentence (6), for the purpose of Clauses (3)(a) and (3)(b), the air leakage rate of a dwelling unit may be assumed to be (a) 2.5 air changes per hour at an air pressure differential of 50 Pa for detached homes, and (b) 3.0 air changes per hour at an air pressure differential of 50 Pa for attached homes.
- ¹⁸⁰ Natural Resources Canada. 2010. Energy Star Qualifying Criteria for Residential Windows, Doors, and Skylights. Available from <https://www.nrcan.gc.ca/sites/www.nrcan.gc.ca/files/energy/pdf/energystar/Fenestration-Spec-E-Residential-October-2010.pdf>
- ¹⁸¹ City of Vancouver. 2017. Energy Efficiency Updates to Vancouver’s Building By-law and Related Additional Changes Report. Vancouver: City of Vancouver. Available from <http://council.vancouver.ca/20170207/documents/rr3.pdf>
- ¹⁸² Ville de Victoriaville, Programme Habitation Durable – Nouvelle Constructions <http://www.habitationdurable.com/victoriaville/nouvelle-construction/construire-durable>
- ¹⁸³ Ville de Victoriaville, Programme Habitation Durable – Nouvelle Constructions <http://www.habitationdurable.com/victoriaville/nouvelle-construction/construire-durable>
- ¹⁸⁴ City of Vancouver. 2017. Energy Efficiency Updates to Vancouver’s Building By-law and Related Additional Changes Report. Vancouver: City of Vancouver. Available from <http://council.vancouver.ca/20170207/documents/rr3.pdf>
- ¹⁸⁵ Ville de Victoriaville. Programme habitation Durable – Grille de pointage pour nouvelles constructions: http://www.habitationdurable.com/victoriaville/images/pdf/41669_Grille%20de%20pointage%202017.pdf
- ¹⁸⁶ City of Vancouver. 2017. Energy Efficiency Updates to Vancouver’s Building By-law and Related Additional Changes Report. Vancouver: City of Vancouver. Available from <http://council.vancouver.ca/20170207/documents/rr3.pdf>
- ¹⁸⁷ Ville de Victoriaville. Programme habitation Durable – Grille de pointage pour nouvelles constructions: http://www.habitationdurable.com/victoriaville/images/pdf/41669_Grille%20de%20pointage%202017.pdf
- ¹⁸⁸ City of Vancouver. 2017. Energy Efficiency Updates to Vancouver’s Building By-law and Related Additional Changes Report. Vancouver: City of Vancouver. Available from <http://council.vancouver.ca/20170207/documents/rr3.pdf>
- ¹⁸⁹ City of Vancouver. 2017. Energy Efficiency Updates to Vancouver’s Building By-law and Related Additional Changes Report. Vancouver: City of Vancouver. Available from <http://council.vancouver.ca/20170207/documents/rr3.pdf>

- ¹⁹⁰ BC Housing. 2017. Illustrated Guide Achieving Airtight Buildings. Victoria: BC Housing. p.6-7. Available from <https://www.bchousing.org/research-centre/library/residential-design-construction/achieving-airtight-buildings>
- ¹⁹¹ BC Housing. 2017. Illustrated Guide Achieving Airtight Buildings. Victoria: BC Housing. p.8. Available from <https://www.bchousing.org/research-centre/library/residential-design-construction/achieving-airtight-buildings>
- ¹⁹² City of Vancouver. 2017. Energy Efficiency Updates to Vancouver’s Building By-law and Related Additional Changes Report. Vancouver: City of Vancouver. Available from <http://council.vancouver.ca/20170207/documents/rr3.pdf>
- ¹⁹³ BC Housing et al. 2017. Energy Step Code: Building Beyond the Standard. 2017 Metrics Research Full Report. Victoria: BC Housing; Ramslie, D. 2017. Costing Preview. Victoria: BC Housing.
- ¹⁹⁴ NRCan. 2012. 2012 R-2000 Standard. Ottawa: NRCan Office of Energy Efficiency.
- ¹⁹⁵ NRCan. 2016. EnerGuide rating 0-100 scale - New Homes. Available from <http://www.nrcan.gc.ca/energy/efficiency/housing/new-homes/18702>
- ¹⁹⁶ BC Housing et al. 2017. Energy Step Code: Building Beyond the Standard. 2017 Metrics Research Full Report. BC Housing.
- ¹⁹⁷ BC Housing et al. 2017. Energy Step Code: Building Beyond the Standard. 2017 Metrics Research Full Report. BC Housing.
- ¹⁹⁸ BC Housing et al. 2017. Energy Step Code: Building Beyond the Standard. 2017 Metrics Research Full Report. BC Housing; BC Housing. 2017. Energy Step Code Convenience Copy. Available from <https://www2.gov.bc.ca/assets/gov/farming-natural-resources-and-industry/construction-industry/building-codes-and-standards/revisions-and-mo/esc-convenienceweb-april2017.pdf>
- ¹⁹⁹ BC Housing et al. 2017. Energy Step Code: Building Beyond the Standard. 2017 Metrics Research Full Report. Victoria: BC Housing.
- ²⁰⁰ BC Housing et al. 2017. Energy Step Code: Building Beyond the Standard. 2017 Metrics Research Full Report. Victoria: BC Housing.
- ²⁰¹ See BC Housing et al. 2017. Energy Step Code: Building Beyond the Standard. 2017 Metrics Research Full Report. Victoria: BC Housing; Ramslie, D. 2017. Costing Preview. Victoria: BC Housing.
- ²⁰² Natural Resources Canada. Net Zero Energy (NZE) Housing. Available from <http://www.nrcan.gc.ca/energy/efficiency/housing/research/5131>
- ²⁰³ CHBA. 2015. Introduction to the CHBA Net Zero Energy (NZE) Labelling Program PILOT. Available from: http://www.chba.ca/CHBADocs/CHBA/NZE/2015-Nov-24_Introduction_to_the_CHBA%20_NZE_Labelling_Program_PILOT.pdf
- ²⁰⁴ Tardiff ing, M., Pope, S., Lubun, M. 2011. From high performance toward Net-zero Energy building in Canada: Overview and long-term perspective. ASHRAE Transactions.
- ²⁰⁵ Tardiff ing, M., Pope, S., Lubun, M. 2011. From high performance toward Net-zero Energy building in Canada: Overview and long-term perspective. ASHRAE Transactions. Assumptions included standard operating conditions, standard equipment performance and a high efficiency gas space heating system.
- ²⁰⁶ Canadian Mortgage and Housing Corporation. Net-Zero energy Housing. Available from https://www.cmhc-schl.gc.ca/en/co/grho/grho_020.cfm
- ²⁰⁷ U.S. Green Building Council. 2013. LEED Reference Guide for Homes Design and Construction. U.S. Green Building Council
- ²⁰⁸ Stephan, A., Crawford, R.H. and de Myttanaere, K. 2013. A comprehensive assessment of the life cycle energy demand of passive houses. *Applied Energy*, 112. 23-34.
- ²⁰⁹ International Passive House Association. https://www.passivehouse-international.org/index.php?page_id=150
- ²¹⁰ Adapted from MMA. 2017. Ontario Building Code. Toronto: Ministry of Municipal Affairs.
- ²¹¹ Adapted from MMA. 2017. Ontario Building Code. Toronto: Ministry of Municipal Affairs.
- ²¹² Adapted from Swinton, M., and Kesik, T. 2005. Performance Guidelines for Basement Envelope Systems and Materials: Final Research Report. Ottawa: Institute for Research in Construction, National Research Council Canada.
- ²¹³ Adapted from Swinton, M., and Kesik, T. 2005. Performance Guidelines for Basement Envelope Systems and Materials: Final Research Report. Ottawa: Institute for Research in Construction, National Research Council Canada.
- ²¹⁴ Adapted from MMA. 2017. Ontario Building Code. Toronto: Ministry of Municipal Affairs.
- ²¹⁵ Adapted from EPA: Urban Runoff, Low Impact Development. <https://www.epa.gov/nps/urban-runoff-low-impact-development>
- ²¹⁶ U.S. Green Building Council, Solar Reflectance Index. <https://www.usgbc.org/glossary/term/5590>
- ²¹⁷ Efficient Windows Collaborative. 2017. Measuring Performance: Solar Heat Gain Coefficient (SHGC). Available from <http://www.efficientwindows.org/shgc.php>
- ²¹⁸ Adapted from Swinton, M., and Kesik, T. 2005. Performance Guidelines for Basement Envelope Systems and Materials: Final Research Report. Ottawa: Institute for Research in Construction, National Research Council Canada.