

**POWER SMART**  
FOR **BUSINESS**



# Energy Efficiency Guide for Municipal Recreation Facilities



\*Manitoba Hydro is a licensee of the Trademark and Official Mark.

## **ACKNOWLEDGEMENTS**

Manitoba Hydro and Recreation Connections Manitoba are grateful to the Saskatchewan Parks and Recreation Association, Saskatchewan Recreation Facility Association, SaskPower, and Associated Engineering (Sask) Ltd. for their permission to copy and update the original version of this publication which was developed in 1991 for Saskatchewan's curling rinks and arenas.

## **DISCLAIMER**

The information contained in this guide is published as a convenient reference for Manitoba Hydro's customers and is distributed without charge. While every effort has been made to provide accurate and complete information, Manitoba Hydro does not warrant the accuracy or efficacy of this information. Manitoba Hydro will not be liable for any loss, costs, damage, or injury whatsoever, resulting from the use of this material.

## Save the watts!

Manitoba Hydro is pleased to sponsor the publication of these guidelines which are designed to help operators of Manitoba's rinks and arenas save money through energy efficiency and lead to an even greater enjoyment of our recreational facilities across the province.

The guidelines present practical ideas for saving money on energy in ice arenas, curling rinks, and similar recreational complexes. They cover a broad range of topics, from funding projects to details of specific components, and apply to new facilities, renovations, and day-to-day maintenance. Each suggestion was carefully researched and reviewed to ensure accuracy and practicality.

It is important to look at your energy efficiency projects carefully. A system that saves you energy dollars but restricts the use of the building and creates a number of uncomfortable situations is an inappropriate choice.

A former rink operator who applied some of the basic ideas covered in this publication was able to cut his energy bills in half after a single season. Such dramatic results are not always possible, but they do show that when you know where to look and what to do, you can achieve substantial benefits.

Our hope is that through the energy efficiency programs and instructions presented here, communities across the province will be able to achieve energy efficiencies, and in doing so, extend their skating and curling seasons.

These guidelines are based on the "Energy Conservation/Management Manual" produced by the Saskatchewan Parks and Recreation Association in cooperation with the Saskatchewan Recreation Facility Association and sponsored by SaskPower. They represent an update of the manual to reflect improvements in technology, Manitoba Hydro's utility rates, and the requirements of Manitoba operators.

We hope these guidelines are helpful.

# Energy Efficiency Guide for Municipal Recreation Facilities

## Table of Contents

<b>1. Electrical and natural gas rates and structures.....</b>	<b>7</b>
Electrical rates .....	7
Terminology .....	7
Rate charges .....	7
Electrical demand .....	8
Season start-up and shutdown .....	8
Natural gas rates.....	8
Natural gas bill components.....	9
Reading your Manitoba Hydro combined energy bill.....	9
Details of electricity, natural gas and other services.....	10
Electrical energy.....	10
Electrical demand.....	10
Natural gas consumption.....	10
Natural gas purchasing options.....	11
What is a natural gas marketer or broker?.....	11
How does signing with a natural gas marketer affect your natural gas bill?.....	11
<b>2. Energy estimating methods.....</b>	<b>12</b>
Reading meters.....	12
Electrical energy reading.....	12
Demand meters.....	13
Natural gas reading .....	15
Keeping your own records.....	15
Inventory of electrical loads.....	15
Estimating your natural gas consumption .....	17
Ordering your Recreation Facility Survey.....	17
<b>3. Making a financial analysis .....</b>	<b>18</b>
Consider your options.....	18
Cost/benefit analysis .....	18
Simple payback.....	18
Net Present Value (NPV) .....	19
Constant dollar value .....	19
<b>4. The building envelope .....</b>	<b>21</b>
Components and systems .....	21
Air barrier .....	21
Materials to use.....	23
Where to seal.....	23
Mistakes to avoid.....	24
Ventilation.....	24
Insulation.....	24
How much is enough?.....	24
Installation.....	25
Cladding.....	26
Roofing.....	26
Vapour retarders.....	26
Moisture problems .....	27
Energy.....	27
Deterioration.....	27
How moisture accumulates in buildings.....	27
Handling moisture.....	27
Wall types .....	28
Studs and drywall or plywood.....	28
Precast concrete .....	28
Metal buildings.....	28
Masonry – reinforced membranes.....	28
Energy efficiency.....	29
Saving with parking lot controllers.....	29
<b>5. Heating and ventilation .....</b>	<b>30</b>
Furnaces.....	30
Electric .....	30
Natural gas/propane .....	30
Oil .....	31
Radiant heaters.....	31
Unit heaters.....	31
Air conditioners.....	32
Rooftop heaters.....	32
Heat pumps.....	33
Hot water/steam systems .....	33
Ventilation .....	35
Natural ventilation.....	35
Health issues.....	35
Carbon monoxide safety .....	36
Mechanical ventilation .....	37
Heat recovery ventilators (HRVs) .....	37
Heat reclaim.....	37
Energy efficiency.....	37
Energy management.....	39
If you don't need it, shut it off .....	39
Domestic hot water.....	39
Demand limiting.....	39

<b>6. Refrigeration.....</b>	<b>40</b>	<b>7. Lighting .....</b>	<b>54</b>
Ice making.....	40	Common sources .....	55
Slab.....	40	Lighting levels.....	55
Slab preparation .....	41	Lighting systems.....	56
Water purity.....	41	Incandescent.....	56
Painting the ice.....	42	T8 fluorescent.....	56
Water purification.....	42	Metal Halide (Standard Technology or	
Ice thickness.....	42	Probe-Start).....	57
Ice melting.....	42	Metal Halide (Pulse-Start).....	57
Ice temperature .....	42	High pressure sodium (HPS).....	58
Mechanical refrigeration.....	43	Low pressure sodium.....	58
The refrigeration cycle in rinks.....	43	Lighting ballasts.....	58
Brine.....	44	Lighting application.....	59
Variable brine temperature.....	44	Converting your fixtures .....	59
Night shutdown.....	45	Daylighting.....	60
Variable speed pumping.....	45	Energy efficiency.....	60
Brine line dehumidifier .....	47	Lighting efficiency.....	60
Refrigeration dehumidifier.....	47	Lighting control.....	60
Controls.....	47	Planning an automatic lighting control system.....	60
Switches .....	47	<b>8. Heating effects of electrical</b>	
Time clocks.....	47	<b>equipment .....</b>	<b>62</b>
Automatic controllers.....	47	Indoor lighting.....	63
Computerized energy management		Outdoor lighting or indoor lighting in unheated	
systems.....	48	areas.....	64
Integrated systems.....	48	Ice plants.....	64
Alternate heat sources/sinks .....	49		
Heat recovery.....	49		
Flood water heating.....	49		
Domestic water heating.....	49		
Space heating.....	50		
Under slab heating .....	50		
Ice melting.....	50		
Electrical.....	51		
Power factor correction .....	51		
Lighting loads.....	51		
Motor selection .....	51		
Demand limiting.....	52		
Low emissivity ceilings.....	52		
Section summary.....	53		

## 9. Operation and maintenance ..... 65

Building envelope.....	65
Symptoms.....	65
Air barrier system.....	66
Insulation.....	66
Cladding – rain penetration.....	66
Vapour retarder.....	66
Heating and ventilation.....	67
Heating equipment.....	67
Ventilation equipment.....	68
Fans.....	68
Filters.....	68
Controls.....	68
Air conditioners.....	68
Heat recovery.....	69
Planned maintenance.....	69
Operation of mechanical systems.....	70
Ice maintenance.....	70
User satisfaction.....	70
Reduced operating costs.....	70
FastICE.....	70
Flooding.....	71
Flooding tips.....	71
Curling rinks.....	71
The pebble – its size and amount.....	72
Water temperature for pebbling.....	72
Maintaining the ice.....	72
Ice edgers.....	73
Uses.....	73
Operating Tips.....	73
Problem areas and solutions.....	73
Goal creases and other wear areas.....	73
Corners.....	73
Boards (edges).....	74
Cracks/chips.....	74
Repairing shell ice.....	74
Ice shaving.....	75
Refrigeration.....	77
Start-up of refrigeration systems.....	77
Pre-start-up.....	77
Actual start-up – single compressor.....	77
Actual start-up – two or more compressors, including mop drum on evaporator; follow the pre-start procedures for a single compressor, then:.....	78

Daily checks after start-up.....	78
Periodic maintenance.....	78
Annual shutdown – general.....	79
Preventive maintenance.....	79
After shutdown.....	80
Leak detection.....	80
Ammonia.....	80
Freon.....	80
Charging oil to a system (adding oil).....	80
Draining oil (ammonia system only).....	80
Charging brine.....	80
Trouble analysis for refrigeration systems.....	81
Trouble shooting.....	83
Safety practices.....	84
First Aid.....	84

## 10. Project planning ..... 85

Project concept.....	85
Demand forces.....	85
Economic base analysis.....	85
Market needs.....	87
Planning process.....	87
Planning for energy efficiency.....	88
Cost avoidance.....	88
Inflation.....	88
Financial analysis.....	89
Planning check list.....	90

## APPENDICES..... 91

1: Glossary of terms.....	92
2: Reference publications.....	95
3: Energy calculations.....	96
4: Power factor correction.....	98
5: Power Smart programs for commercial buildings.....	110

# 1. Electrical and natural gas rates and structures

In most types of recreational facilities, the largest single cost is the monthly utility bill. Here are some insights on how you are charged and how to look for potential energy savings.

## Electrical rates

Energy efficiency in rinks and arenas means saving money and the environment. It starts with an understanding of the costs associated with energy use.

## Terminology

The following are some of the key terms used to describe the electrical energy your facility consumes:

- **Kilowatt hours (kWh).** Electrical energy is measured in kilowatt-hours. For example, a 2-kilowatt appliance operating for five hours consumes 10 kWh of electrical energy.
- **Kilovolt ampere (kVA).** Electrical demand is measured in kilovolt-amperes. It is voltage multiplied by current divided by 1,000. In most facilities and applications the total power measured in kilowatts is the same or close to the kVA demand.
- **Basic rate.** The fixed monthly amount that is charged for each service. There is a charge for single-phase service and a slightly higher charge for three-phase service.
- **Runoff rate.** The amount charged for the last block of the kWh consumed each month. When you turn on a light switch or start a piece of equipment you begin to consume energy. You are charged for every kilowatt hour (kWh) that you consume.
- **Electrical demand** is the peak amount of power drawn through a meter during a specific billing period, usually one month. It is expressed in kilovolt-amperes (kVA). The electrical service must be sized and have the capacity to supply the maximum amount of energy that may be required. Manitoba Hydro must ensure that it has the capacity to supply the maximum amount of energy “demanded.” As a result, it charges for demand as well as energy consumed.

- **Energy charge.** The amount you are charged for energy varies with how much you use each month.
- **Demand charge.** The amount you are charged for the peak electrical power or demand you required over the last month.

## Rate charges

Energy rates can change often, so no attempt has been made to indicate the actual charges in this booklet. For the current energy rates, check our website at [hydro.mb.ca/regulatory\\_affairs/energy\\_rates/index.shtml](http://hydro.mb.ca/regulatory_affairs/energy_rates/index.shtml)

There are four electrical rates that can be used to calculate the monthly electrical costs charged to a recreation facility:

- **General Service Small Non-Demand** for small recreation facilities with no demand.
- **General Service Small Demand** for small to medium recreation facilities with demands up to 199 kVA.
- **Medium Service** for medium to large recreation facilities with demands of 200 kVA and over per month.
- **Large General Service** for large commercial customers who own their transformers. This rate has different demand and energy charges, based on the voltage supplied by Manitoba Hydro to the site.

## Notes:

Minimum monthly bill for all rates is the Basic Charge plus any minimum demand charge.

For General Service Medium and General Service Large, the demand charge is applied to the Monthly Billing Demand. Monthly Billing Demand is defined as the greater of the following, expressed in kVA:

- Measured demand;
- 25 per cent of contract demand;
- 25 per cent of the highest demand in any of the previous 12 months.

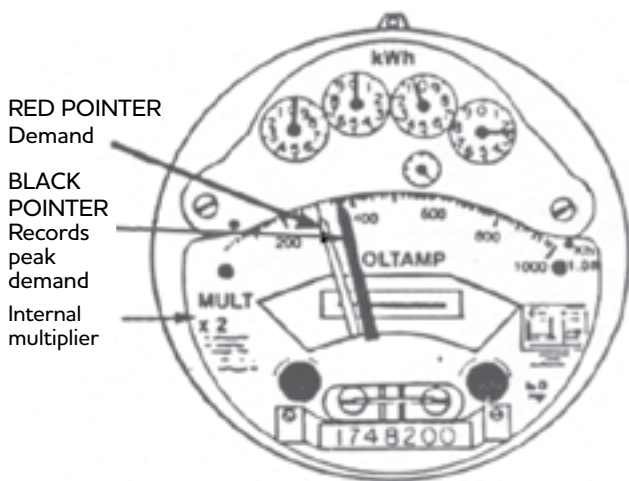

Typical electrical demand meter. The red pointer tracks demand, while the black pointer tracks peak demand.

## Electrical demand

Demand is the peak amount of power drawn through a meter during a specific billing period, usually one month. It is expressed in kilovolt-amperes (kVA). Rinks and arenas with ice plants require large supplies of electricity. The electrical service must be sized and have the capacity to supply the maximum amount of energy that may be required. Manitoba Hydro must ensure that it has the capacity to supply the maximum amount of energy “demanded.” As a result, it charges for demand as well as energy consumed.

For customers who own their transformers, demand rates vary, based on the voltage supplied by Manitoba Hydro to the site.

The demand meters in most ice plants are thermal, with the rest being electronic. Electronic demand meters are discussed in Section 2. Here is an example to give you some idea of how demand charges are determined and how to avoid paying them unnecessarily. Lets say that you need to start an ice plant that draws about 100 kVA. The demand meter registers that a large load has been activated but it does so gradually because it uses a thermal element to measure demand. After one minute, the demand reading is 25 per cent of actual; after four and a half minutes, 50 per cent; after 15 minutes, 90 per cent; and after half an hour, 99 per cent. In this example, the demand meter will reach 50 kVA after four and a half minutes, and 99 kVA in 30 minutes. If you run your compressor for only 30 minutes, you will be charged the full demand charge of over \$800 for the month.

## Season start-up and shutdown

Knowing when your meter is read can save you the demand charges for an entire month.

For example, if you start your ice plant on September 15 and your meter is read on September 17, you will be charged the full demand charge for the billing period ending September 17, even though you only used the ice plant for 2 days.

If you waited until after the meter was read on September 17, then started the ice plant, you would save one full month’s demand charge.

For example, if you were operating a 60 hp ice plant, you could save over \$400 in demand charges including taxes by waiting two days to start the compressor.

The same is true of the end of the season. If you suspect that the meter will be read on April 17 and can shut the ice making equipment off on April 16, try to do so. You’ll save over \$400 in demand charges. If the plant runs until April 20, you’d be charged the full demand charge for the next period.

Find out when your meter will be read by contacting your local Manitoba Hydro district office.

## Natural gas rates

The natural gas industry in Canada was deregulated in 1985 and now gives customers more choices when they purchase natural gas. Knowing exactly what you pay can help you make informed decisions about your natural gas supply and encourage the development of a competitive marketplace.



## Natural gas bill components

Before July 1999, Manitoba Hydro billed its customers for natural gas usage through a single charge called the "Gas Charge." To give its customers more detail on what they pay for natural gas and its transportation and delivery, Manitoba Hydro split the Gas Charge into its components:

- Primary Gas;
- Supplemental Gas;
- Transportation to Manitoba Hydro;
- Distribution to the customer.

The total monthly cost of natural gas is determined by adding the charges for each of these components plus a basic monthly charge.

**Primary Gas.** This is the natural gas received from Western Canada. It can be purchased on an unregulated basis from a natural gas marketer (broker), or from Manitoba Hydro Gas at rates regulated by the PUB. The price that Manitoba Hydro pays for its Primary Gas supply is passed directly on to the customer without any mark-up. During normal weather, this typically averages about 96 per cent of a customer's annual natural gas use. The actual percentage fluctuates during warmer or colder than normal years and can vary one to two percentage points every quarter.

**Supplemental Gas.** This is natural gas that Manitoba Hydro purchases to ensure supply is available when demand is higher than normal. Supplemental gas usually represents about 4 per cent of a customer's annual natural gas use. The actual percentage fluctuates during warmer or colder than normal years and can vary one to two percentage points every quarter.

**Transportation to Manitoba Hydro.** This is the cost of transporting natural gas to Manitoba, including pipeline charges and the cost of storage facilities where Manitoba Hydro stores natural gas purchased in the summer for use in the winter.

**Distribution to Customer.** This is the cost of delivering natural gas to a customer's home or business. It includes the cost of pipe and facilities that Manitoba Hydro has installed, as well as the operation and maintenance costs of the distribution system. A portion of these costs is recovered through the Basic Monthly Charge.

**Basic Monthly Charge.** This fixed charge pays a portion of the cost of providing service and does not depend on how much natural gas a customer uses.

It helps pay for such things as the maintenance of meters and underground pipelines, the cost of meter reading, billing, and record keeping. The amount of the Basic charge depends on the type and size of gas service that is provided.

Most recreational facilities with access to natural gas use either the Small General Service (SGS) or Large General Service (LGS) rates, which are available to customers with annual volumes less than 680 000 m<sup>3</sup>. Customers who use more than 680 000 m<sup>3</sup> can be on a rate called High Volume Firm or Interruptible Service.

Check our website at [hydro.mb.ca/regulatory\\_affairs/energy\\_rates/index.shtml](http://hydro.mb.ca/regulatory_affairs/energy_rates/index.shtml) for the most current natural gas rates.

## Reading your Manitoba Hydro combined energy bill

To help streamline customer service, Manitoba Hydro has combined your electricity and natural gas account into one customer system. Since February 2006, Manitoba Hydro has been sending out a combined energy bill which includes all of your electricity and natural gas charges, and any other applicable information and charges. As a result, all accounts now have a 14-digit combined energy account number.

Here are the highlights of several key pieces of information on your energy bill to help you in your energy planning. If you still have questions about your bill after reading this, contact your local Energy Services Advisor or call the number shown in the Customer Inquiries portion of your bill.

The first page of the new bill is the summary page and indicates contact information and a summary of the bill components at a glance.

As a convenience, all of your electricity, natural gas, and any other charges for the service location are totaled on page one so one payment can be readily made. The back of page one contains payment and reading information.

## Details of electricity, natural gas and other services

Details of meter reading and of billing calculation for electricity, natural gas and other services are found on your energy bill.

### Electrical energy

The first line of the electrical section explains when your electrical meter was read and how the energy you consumed was calculated. The end of the line explains whether readings were regular, verified, or estimated. "Verified" means that reading was double-checked to ensure accuracy.

Electrical consumption is calculated by subtracting the previous meter reading from the present meter reading and multiplying the result by the multiplier. The result is the actual number of kWh consumed for the billing period.

### Electrical demand

The next line or demand portion of the bill is just as important as the energy portion. For some buildings, demand charges can be as much if not more than the energy charges.

Demand is read and reset every month so there are no previous and present readings to subtract, just the actual demand reading for the month.

Demand is read in volt-amperes and converted to kilovolt-amperes by dividing the reading by 1,000.

The resulting value is then multiplied by the meter multiplier to get the final demand reading.

The calculation section shows the basic charge, energy charge for each block and the taxes that make up the energy portion of the bill. The demand charges and applicable taxes for the demand portion are shown in detail. The sub total for each portion is then added to show the total for the bill.

## Natural gas consumption

The first line of the natural gas portion of the bill shows you when your natural gas meter was read and how the natural gas consumption was calculated. At the end of the line you are told if your natural gas meter reading was regular, verified, or estimated. "Verified" means the reading was double-checked to ensure accuracy.

Natural gas consumption is calculated by subtracting the previous meter reading in cubic feet from the present meter reading in cubic feet, then multiplying the result by two different multipliers.

The first is a pressure adjustment value for the location. The second converts the reading from cubic feet to cubic metres.

The balance of the bill shows component charges, explained earlier in this section, the monthly basic charge, applicable taxes, and the total charge for natural gas consumption. As in the case of questions about your electrical bill, contact your Energy Services Advisor or the number shown in the Customer Inquiries portion of your bill for further details.

The last page or page four of the bill has useful tables and information which will help you understand energy consumption in your building. If you subscribe to the Equal Payment Plan, a table at the top of page four provides information for each meter, showing the difference between the equal installments billed and the actual energy consumed for the month. Billing information on other services such as flat rate dusk to dawn sentinel lights or hot water tanks is shown in the next section. A very useful table called Consumption History provides a comparison between energy used during the billing period this year and energy used for the same period last year. This will allow you to see if energy management projects are still working properly month to month. A glossary of terminology that relates to your services is featured in the last section when there are new energy charges.

Energy bills are not just for the accountant. As a facility manager, you should also see the bills so that you can keep track of energy and demand use in the facility and spot any problems with consumption as they occur.

## Natural gas purchasing options

Natural gas is a commodity that is bought and sold in a highly competitive market where prices rise and fall every day. Almost all natural gas consumed in Manitoba is purchased from Alberta.

Currently, Manitoba Hydro customers have the option of purchasing their Primary Gas supply through Manitoba Hydro or through a natural gas marketer or broker.

If a customer chooses to have a marketer supply their Primary Gas, Manitoba Hydro will continue to provide and bill them for all non-Primary Gas related billing components (Supplemental Gas, Transportation to Manitoba Hydro, Distribution to Customer, and the Basic Monthly Charge).

Whether a customer purchases their Primary Gas supply from Manitoba Hydro or from a marketer, Manitoba Hydro will transport all Primary Gas supplies from Alberta through the Trans Canada Pipeline and will deliver it to their premises. Manitoba Hydro will also continue to provide all other elements of their natural gas service.

## What is a natural gas marketer or broker?

Natural gas marketers, or brokers, are independent companies that arrange alternate rates and terms of service for Primary Gas supply. Marketers offer the option of different terms of pricing than that offered by Manitoba Hydro, such as a fixed rate for a fixed period of time. Marketers only arrange a customer's Primary Gas supply, they do not deliver the natural gas or provide utility services.

## How does signing with a natural gas marketer affect your natural gas bill?

If you sign an agreement with a natural gas marketer for your Primary Gas supply, you will continue to receive a bill from Manitoba Hydro. Manitoba Hydro will continue to provide all the other components of your natural gas supply and service.

You'll see these changes on your bill:

- Your Primary Gas charge will reflect the rate you agreed to with your natural gas marketer. Your natural gas marketer's name will appear in the Primary Gas line.
- You'll find the name and telephone number of your natural gas marketer listed for your reference. Your natural gas marketer can answer all your questions about your Primary Gas supply, rate and agreement.

- The other components of your natural gas bill will be supplied and billed as usual, regardless of who provides your Primary Gas. Your total monthly bill will continue to be the sum of all of the various bill components.

Customers who choose a fixed rate contract for a long term with a natural gas broker will always know what their Primary Gas rate is over that term. Their Primary Gas rate will not increase if market prices for natural gas increase.

On the other hand, their Primary Gas rate will not decrease if market prices for natural gas go down, they will pay the rate they agreed to for the length of the contract.

Here are a few differences about the rates offered by Manitoba Hydro and brokers:

- Manitoba Hydro makes no profit from the sale of Primary Gas. This is not true of gas brokers.
- Manitoba Hydro changes its Primary Gas rate on a quarterly basis, to reflect the changing costs of natural gas in the open market. Manitoba Hydro's Primary Gas rate may go up or down every three months.
- Natural gas brokers generally offer a fixed rate for Primary Gas over a specific length of time, such as three to five years. A broker requires a customer to sign a contract that locks in the rate they pay for their Primary Gas for up to five years.
- Natural gas brokers are only offering to supply your Primary Gas; therefore the other items on your bill such as Supplemental Gas, Transportation to Manitoba Hydro and Distribution to customer will still appear on your bill at the usual regulated rates.
- The Public Utilities Board of Manitoba regulates and approves all of Manitoba Hydro's rates, including its Primary Gas Rate.
- The Public Utilities Board does not regulate natural gas brokers' Primary Gas rates. (Primary Gas is the only component of natural gas service that brokers can provide.)

## 2. Energy estimating methods

This section explains how to read your meters so that you can trace energy use to specific areas or functions. It presents a generic inventory sheet that you can adapt to keep track of your electrical loads. The three major energy users, namely the building, heating and refrigeration systems are covered in later sections.

### Reading meters

Charges for electricity and gas represent from 30 to 40 per cent of the average rink or arena's annual total expenses. Although it is as important to manage these costs as it is to manage labour costs, they often go unattended.

Most rinks and arenas have demand meters installed. Here is a brief description of these meters, which are capable of reading two distinctly different values: energy and demand.

Electricity consumed is measured in kilowatt hours (kWh).

Natural gas consumed is measured in 100 cubic feet or 1,000 cubic feet and billed in cubic metres. There are approximately 35,310 Btu (10.35 kWh) in a cubic metre of natural gas.

Demand is the rate at which electrical energy is delivered to a load. It is expressed in kilovolt amperes (kVA), and is billed based on the largest amount of power drawn through the meter during a monthly billing period.

There is no demand charge for natural gas – unless consumption exceeds 680,000 cubic metres/year.

### Electrical energy reading

By reading the dials at the top of your electrical meter, you can determine how much energy you use, in kWh.

See below for a close-up of an electrical meter with four dials. Larger energy users may have five or more dials on their meters.

Each dial rotates in the opposite direction from the one beside it. Dial 1 rotates clockwise, dial 2 counter clockwise, dial 3 clockwise, and so on.

As dial 1 completes a full revolution, dial 2 will rotate one tenth of a revolution, from 0 to 1, or 1 to 2, etc. When dial 2 completes one full revolution, dial 3 will rotate one-tenth of a revolution.

Read the dials from right to left, and write the figures in the same order—from right to left.

When the pointer on the dial is between two digits, it is read as the smaller number, just as you would read an ordinary clock. For example, the meter reading in the figure below is 7831.

Not all readings are quite as obvious as they are in this example.

*Dials on an electrical meter. Here the dials read 7831.*

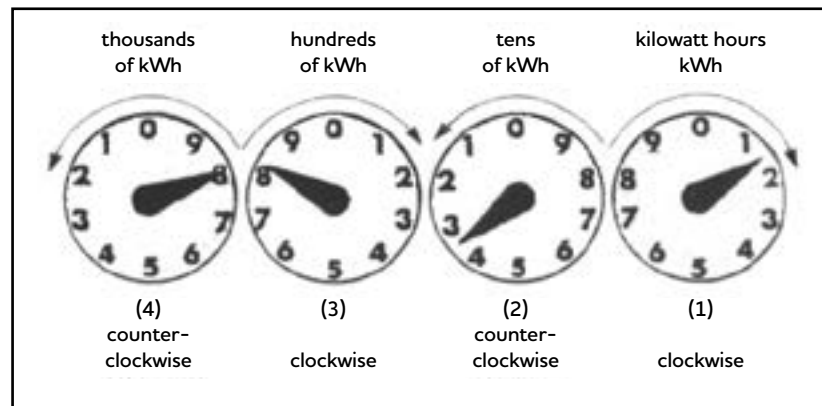

Red pointer, which tracks demand

Black pointer, which marks peak demand



Conventional electrical demand meter. The red pointer records demand. As it moves up, it pushes the black pointer with it. When the red pointer falls back, the black pointer remains behind to mark peak demand. Each month your meter reader records the reading on the black pointer.

## Demand meters

There are two types of demand meters: thermal and electronic. Most demand meters are of the thermal type.

**Reading a thermal demand meter.** A thermal demand meter has two pointers: one is red and the other black. The red pointer is controlled by a thermal coil. As energy passes through the meter, the coil heats, expands, and moves the red pointer up the scale. When the red pointer advances, it drives the black pointer forward at the same rate.

When electricity passing through the meter starts to drop, the thermal coil cools, contracts, and moves the red pointer back down the scale.

Meanwhile, the black pointer remains behind at whatever peak it was pushed to by the red needle. In this way, the black needle records the maximum demand during the billing period.

Heating and cooling of the coil does not happen instantaneously. There is a time lag. As noted earlier, after 1 minute, the demand reading is 25 per cent of the actual demand; after 4 1/2 minutes it registers 50 per cent of actual demand; after 15 minutes, 90 per cent; and after half an hour, 99 per cent.

After the meter is read, the meter reader manually resets the black pointer to the red pointer. This procedure is repeated every time the meter is read.

The actual voltage and current is often too large to be registered directly by your meter. The meter's registering capacity is only a small percent of your actual load.

By way of an analogy, the distance between two centres may be 500 miles, but on a map this would be represented by only 5 inches. The meter multiplier is similar to the map scale in that it relates the meter's scaled-down reading to actual consumption. A meter has both an internal and external multiplier. When the internal and external multipliers are multiplied by one another, the result is the overall multiplier, as in the following equation:

$$\text{overall multiplier} = \text{internal multiplier} \times \text{external multiplier}$$

For example, assume you need 600 volts and 400 amps to run your operation. The maximum capacity of your meter is 120 volts and 5 amps. The volts and amps must be reduced or stepped down by transformers before entering the meter. The factor by which they are reduced is known as the multiplier. In this example:

$$600 \text{ divided by } 120 = 5 \text{ (5 is the voltage multiplier)}$$

$$400 \text{ divided by } 5 = 80 \text{ (80 is the current multiplier)}$$

$$5 \times 80 = 400 \text{ (400 is the external multiplier)}$$

The external multiplier is not indicated on your meter but on a tag attached to it. The internal multiplier is shown on the meter face. It is a result of the mechanical workings of the meter. In the meter above, the internal multiplier is 2.

In this example the overall multiplier would be the internal multiplier (2) times the external multiplier (400) or 800. The overall multiplier is indicated on your bill and on a fibre tag wired to your meter.

Understanding the energy dials and demand register of your meter requires a little effort – but an effort worth making. Contact your local Manitoba Hydro office for additional information on your demand meter.

**Reading an electronic demand meter.** The second type of electrical demand meter is known as an electronic meter.

Values for energy and demand are read off a digital display. Here are the values that can be read off the digital display of one of the more popular electronic demand meters:

### Values displayed in a popular electronic demand meter

Code	Displayed value	Description
NONE	8's + SUB TITLES	All segment check
02	0000 kWh	kWh consumption
03	0000 VA Max	VA peak demand
04	00 RST	Number of resets

The meter comes with a tag that shows the multiplier you need to use.

Say that you want to determine the quantity of electricity in kilowatt hours that your facility has consumed over the past week. You will need to determine the difference between the two kilowatt hour register readings now and a week ago, then multiply by the external multiplier stamped on the fibre tag wired to your meter.

For example:

Current kWh register reading = 6,197 kWh  
 Reading one week ago = 6,152 kWh  
 Register difference = 45 kWh

Actual energy consumption for the week is:  
 45 kWh x 360 (external multiplier) = 16 200 kWh

To determine peak demand from the meter, you would select the proper code to display the VA Peak Demand. You would multiply the number displayed by the external multiplier, then divide the result by 1000 to obtain peak demand in kVA.

For the meter in VA mode shown below on the right, since the meter was last reset, peak demand would be determined as follows:

$$(0631 \text{ VA MAX} \times 360) / 1000 = 227 \text{ kVA}$$

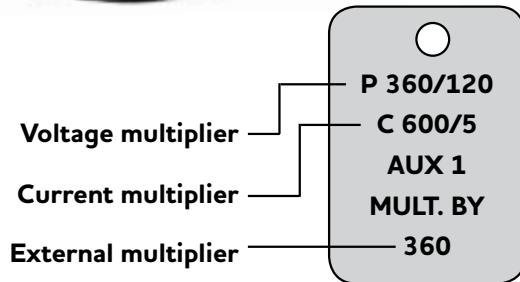

Front panel of an electronic meter for reading energy and demand. The meter is shown in energy consumed mode (left) and in demand mode (right). The tag below gives the multipliers for this meter.

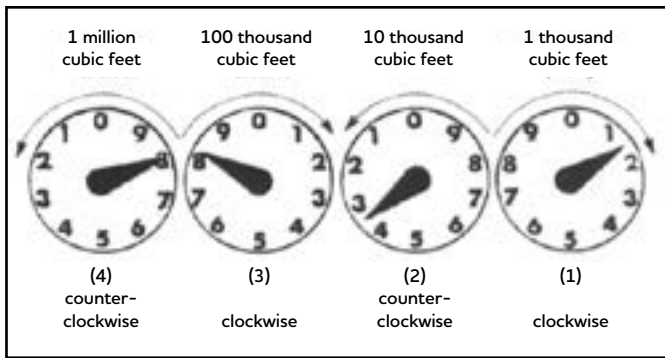

Dials on a typical natural gas meter

## Natural gas reading

The gas meter on the natural gas service to your facility measures the volume of gas supplied. Reading the dials is similar to the method for reading electrical energy dials.

Dials rotate clockwise or counter clockwise. You always read the smaller number when the pointer is between numbers and a multiplier is applied to the meter reading to determine the actual consumption.

Your local Manitoba Hydro Energy Services Advisor will be pleased to answer any questions you have about your gas meter.

## Keeping your own records

By reading your own meters you will be able to keep track of total energy consumed and avoid surprises.

Pick a schedule that suits your purposes and read your meters regularly. Record the date, time, and energy readings, as well as the demand reading.

You will need to subtract the previous energy reading from the current reading and multiply the difference by the appropriate billing multipliers.

The product is the total kilowatt hours of energy used or the cubic metres of gas burned.

It is a good idea to record average temperatures to relate energy consumption to weather conditions.

By keeping good records you will immediately know about any major shifts in energy use and be able to investigate them as soon as possible.

If gas usage increases significantly, it may be an equipment problem, something running too long, or a gas leak. If electrical consumption increases significantly, look for something being left on, or something broken. If demand increases, check for new loads being added or increases in the size of loads.

## Inventory of electrical loads

Electric energy consumed by the various connected pieces of equipment (loads) can be estimated by reviewing the name plate on each unit. By keeping an accurate inventory of the loads, you will begin to understand how the power is being used in your facility.

The following table lists the major loads for a rink with an all-electric kitchen.

## MAJOR ELECTRICAL LOADS – Rink with an all-electric kitchen

	Load [kW]	Average run time per week [h]	Energy per week [kWh]
Compressor (ice plant)	75	100	7,500
Evaporative condenser	10	75	750
Brine circulation pump	15	168	2,520
Arena lights	25	112	2,800
Public area lights	10	112	1,120
Fryer	15	30	450
Range	25	30	750
<b>TOTALS</b>	<b>175</b>		<b>15,890</b>

In this example, the single largest energy user is the compressor, then the lights and the brine pump – just as you might expect. Kitchen consumption, totalling 40 kW, is near or at the bottom of the energy list.

The demand side of this equation presents a different picture. Based on \$9.45/kVA over 50 kVA, an additional 40 kVA from the kitchen actually costs \$378/month despite only being operated for 30 h/week (120 hours/month). The corresponding energy cost in the kitchen for the same period would be \$44.30 at the \$0.03692/kWh runoff rate.

This is a very simplified example but it does point out the discrepancies that can occur when demand charges are not recognized. If this is occurring in your facility, try to reduce the combined loading by limiting the demand, either manually or with demand limiting controls as discussed further in a later section.

Use the following sheet to create your own electrical inventory and calculate energy costs. By adjusting the run times or connected load you can recalculate the impact of changes to scheduling or equipment modification/replacement.

## Taking your electrical inventory

LOAD	SIZE		OPERATING TIME		ENERGY CONSUMPTION
<b>Refrigeration</b> (to get approximate kW, multiply name plate horsepower of motor (hp) x 0.746)					
Compressor	_____ kW	x	_____ hrs	=	_____ kWh
Brine pump	_____ kW	x	_____ hrs	=	_____ kWh
Condenser fan	_____ kW	x	_____ hrs	=	_____ kWh
Condenser pump	_____ kW	x	_____ hrs	=	_____ kWh
Other refrigeration	_____ kW	x	_____ hrs	=	_____ kWh
<b>Lighting</b>					
Arena lights	_____ kW	x	_____ hrs	=	_____ kWh
Other lights	_____ kW	x	_____ hrs	=	_____ kWh
<b>Electrical</b>					
Other electrical loads	_____ kW	x	_____ hrs	=	_____ kWh
Kitchen equipment					
Range	_____ kW	x	_____ hrs	=	_____ kWh
Fryer	_____ kW	x	_____ hrs	=	_____ kWh
Fan	_____ kW	x	_____ hrs	=	_____ kWh
Other	_____ kW	x	_____ hrs	=	_____ kWh
<b>HVAC equipment</b>					
Water heaters	_____ kW	x	_____ hrs	=	_____ kWh
Furnace motors	_____ kW	x	_____ hrs	=	_____ kWh
Electric space heaters	_____ kW	x	_____ hrs	=	_____ kWh
Ventilation units	_____ kW	x	_____ hrs	=	_____ kWh
Air conditioning	_____ kW	x	_____ hrs	=	_____ kWh
Other	_____ kW	x	_____ hrs	=	_____ kWh
Other	_____ kW	x	_____ hrs	=	_____ kWh
<b>TOTALS</b>	_____ kW				_____ kWh
	<b>DEMAND ②</b>				<b>ENERGY ①</b>

## Energy calculations

Total energy consumption from ① = \_\_\_\_\_ kWh

1st 11,090 kWh x \$0.08058/kWh = \$ \_\_\_\_\_

Next 8,500 kWh x \$0.05594/kWh = \$ \_\_\_\_\_

(Total - 19,500 kWh) x \$0.03692/kWh = \$ \_\_\_\_\_

**Total energy costs** = \$ \_\_\_\_\_ ③

Demand calculation from line ② (assuming a high power factor) = \_\_\_\_\_ kW = kVA

First 50 kVA \_\_\_\_\_ FREE \_\_\_\_\_

Total kVA-50 kVA \_\_\_\_\_ (Billed kVA)

Billed demand \_\_\_\_\_ kVA x \$9.45 if greater than zero = \$ \_\_\_\_\_ ④

Basic monthly charge (single phase \$20.51; three phase \$28.92) = \$ \_\_\_\_\_ ⑤

Total of ③ + ④ + ⑤ = Total billing costs (before taxes) = \$ \_\_\_\_\_



## Estimating your natural gas consumption

Natural gas consumption can be estimated easily for stable loads such as domestic hot water heating and gas fired cooking appliances. Heating loads that are subject to weather effects, or ventilation loads that vary with weather and occupancy, require a more sophisticated analysis.

Remember that fuel-fired appliances must be pro-rated, depending on their steady-state and seasonal efficiencies, to determine their actual fuel consumption. For a further discussion of heating equipment see Section 5.

Some engineering design companies operate computer based energy simulation programs that predict the total energy used by a facility. The programs use computer models that take into account:

- building shell;
- heating systems;
- ventilation system;
- lighting;
- weather;
- people;
- other miscellaneous internal and external loads.

The base model is then checked against actual operating costs.

Energy saving ideas are then added to the model. Schedules are modified and loads are adjusted, then run on the computer. The revised system performance is compared to the base case to determine the potential savings and how these various measures might interact with each other.

The use of computer models is not cheap, but it can save you money – by helping you avoid making a mistake. The computer will model many types of energy conserving measures to predict effects. It may even predict that a measure which was thought to save money ends up costing more in either capital costs or operating costs. It's a lot easier to fine tune a computer model than it is to fix up an entire arena complex.

## Ordering your Recreation Facility Survey

Manitoba Hydro has created the Recreation Facility Survey to help operators of ice arenas and curling rinks save energy in their facility by gaining an understanding of their energy use and potential energy-saving measures.

The survey is a comprehensive examination of equipment and the use of energy in your facility. Taking the time to complete the survey is time well spent.

A professional engineer reviews the completed survey and produces a report for you. The report compares the energy use of your facility with other similar facilities in Manitoba. Tables compare the annual energy consumption and costs of your facility with other typical facilities to show how your facility uses energy and pinpoint potential energy savings. Monthly profiles for energy consumption, billed peak demand, and associated costs are also produced to show how much energy you use each month.

The report lists possible energy savings opportunities that apply to your facility.

Going through this exercise also offers the benefit of an up-to-date inventory of your building, for future use.

You can order a copy of the Recreation Facility Survey by:

- Phone: 204-360-3676 (Winnipeg)  
or 1-888-624-9376
- fax: 204-360-3017
- email: [powersmartforbusiness@hydro.mb.ca](mailto:powersmartforbusiness@hydro.mb.ca)
- mail: Manitoba Hydro  
Commercial Programs (7th floor)  
360 Portage Avenue  
Winnipeg, MB R3C 0G8
- web: [hydro.mb.ca/your\\_business/recreation\\_facilities](http://hydro.mb.ca/your_business/recreation_facilities)

If you have any questions about the survey, please contact your Manitoba Hydro account representative. See the back cover for our website to find the representative in your area.

# 3. Making a financial analysis

This section covers three simplified methods of gaining a quick feel for the value of your planned energy efficiency and building projects.

Complex methods are also available through financial consultants for an in-depth analysis to ensure that the dollars spent are put to their best use and work as hard for you as you have worked for them.

Each facility takes a different approach to finances, depending on where you get your funds, how you spend them, the people involved, and the traditions established in your community.

Financial priorities, which tend to vary, will influence when and what you spend your money on. Some communities take out loans while others insist that all money is in the bank first. Financial priorities may also influence the types of projects you undertake, from repair to replacement.

## Consider your options

When considering project options, look at your current facilities and plan for the future. Remember that all buildings and facilities require regular maintenance and up-keep to ensure a long life, but eventually everything wears out and needs to be replaced. See Section 10 for detailed project and facility planning options and analyzes.

Energy efficiency projects are a realistic way to save dollars and reduce expenses. Analyze your options to determine their impact on facility operation and cost.

Simple operating adjustments can yield savings without cash outlay. Modifying, replacing, or adding equipment costs money up front but saves dollars in the long run. When opportunities arise for significant reductions in overall operating costs, act on them after considering them carefully to avoid costly mistakes.

If your facility relies on fundraising or government grants for money, you will appreciate that it is far easier to raise money to cover new projects than it is to cover operating and maintenance costs.

## Cost/benefit analysis

A cost/benefit analysis is simply a way of looking at an investment to determine if the benefit justifies the cost. The value of the benefit is often difficult to establish, especially in public facilities.

For example, a new public washroom will not generate revenue by itself (pay toilets excepted). But if the improvement makes the facility more attractive to the public and attendance at events increases, the benefit becomes real.

Energy efficiency projects generally show a direct benefit in reduced operating costs. The cost of the project can be directly compared to the savings in utility costs.

Lower facility maintenance costs are another type of benefit. With 50 to 60 per cent of a rink's annual expenditures going to wages and maintenance, projects that reduce the need for maintenance or extra staff will have a significant effect on the building's finances.

For example, if plastic pipe coverings were installed over pipes and tanks that were customarily painted every year, you would eliminate annual painting and benefit from reduced annual maintenance. Similarly, installing a low emissivity ceiling may eliminate the need to paint the ceiling every 10 years.

## Simple payback

As the name suggests, simple payback is a simple analysis method that looks only at paying back the capital cost. For example, you install a new heating system, at a cost of \$28,000, to heat the building in your rink. The new heating system saves you \$5,600 a year in energy costs. The simple payback is:

$$\$28,000/\$5,000 = \text{Five years}$$

In roughly five years you will have saved enough money through energy costs to pay back the capital cost of the installation. Note that this approach excludes financing costs and energy inflation costs.

Although simple payback is commonly used to evaluate energy efficiency projects, it suffers from serious flaws because it over simplifies often complex financial and economic situations.

## Net Present Value (NPV)

NPV is similar to simple payback except that it measures the excess or shortfall of cash flows, taking the time value of money into account. The time value of money is just the cost of capital (financing costs, if the project is financed).

NPV is the sum of all the cash flows associated with an investment, with each cash flow discounted back to a base year (usually the present). The discount rate used is the cost of capital.

As a money manager you expect a specific minimum return on your money. A return of 12 per cent is used throughout these guidelines. NPV indicates how much better or worse than the specified return (12 per cent) your proposed investment will be. A positive calculation indicates better than a 12 per cent return on investment. A negative value indicates worse than a 12 per cent return on investment.

For example, if an owner invests the required \$28,000 in the above example using a 12 per cent annual rate over the 10-year useful life of the project, then an NPV can be calculated as follows, using the annual savings of \$5,600:

$$\text{NPV} - 28,000 = 5,600/(1.12) + 5,600/(1.12)^2 + \dots + 5,600/(1.12)^{10} = +3,641$$

After accounting for the 12 per cent financing costs, the project will generate a gain of \$3,641.

Note that the analysis has not escalated annual savings; however, as utility rates go up, so should savings. If the rates were to go up 5 per cent per year, the NPV would become:

$$\text{NPV} - 28,000 = 5,600 \times (1.05/1.12) + 5,600 \times (1.05/1.12)^2 + \dots + 5,600 \times (1.05/1.12)^{10} = + 11,945$$

If utility rates increased at 5 per cent, the project would generate a gain of \$11,945 accounting for the 12 per cent cost of capital.

This analysis has still ignored a number of key factors. For example, how does the new equipment interact with existing equipment. Will existing equipment operate less and therefore last longer?

Delaying replacement of expensive equipment should be of some value, shouldn't it? And how about maintenance costs; are these affected as well?

A proper financial analysis considers all related costs and benefits, direct and indirect, over the project life, before drawing any conclusions.

## Net present value – capital reserves

Year Number	Future energy savings	Present \$ net annual cashflow	Present \$ cumulative cashflow
0	00.00	-28,000.00	-28,000.00
1	5,880.00	5,250.00	-22,750.00
2	6,174.00	4,921.88	-17,828.13
3	6,482.70	4,614.26	-13,213.87
4	6,806.84	4,325.87	-8,888.00
5	7,147.18	4,055.50	-4,832.50
6	7,504.54	3,802.03	-1,030.47
7	7,879.76	3,564.40	2,533.94
8	8,273.75	3,341.63	5,875.56
9	8,687.44	3,132.78	9,008.34
10	9,121.81	2,936.98	11,945.32

Future worth of energy is based on the formula  $5,600 \times 1.05^n$  where  $n$  = year number. For example, in year five, the future energy savings will be  $5,600 \times 1.05^5 = 7,147.18$ .

Payments in year zero represent the purchase price.

## Constant dollar value

The constant dollar value method takes inflation into account. All costs and prices are discounted by the assumed rate of inflation to express the dollar values in terms of the starting year's dollar. The cost of money is not considered in this analysis.

An item worth \$1,000 today will cost \$1,040 a year from now. Conversely a payment of \$1,000 due a year from now is worth \$961.54 in today's dollars. You can calculate this with the following formula:

$$\text{CDV} = \frac{\text{FDV}}{(1 + I)^n}$$

Where:

CDV = Constant dollar value

FDV = Future dollar value

I = Inflation rate

n = Number of years in the future

Under this equation, if inflation is 4 per cent per year:

$$\begin{aligned} \text{CDV in year 1} &= \frac{\$1,000}{(1 + .04)^1} \\ &= \$ 961.54 \end{aligned}$$

The escalation rate of energy costs can be different than inflation and will modify the future dollar value. Multiply the current costs by the price escalation rate to get the future dollar value. Be sure to take each year's rate into account.

Let's consider the example earlier of a \$28,000 investment with annual energy savings of \$5,600. Energy costs escalate at 5 per cent and inflation is at 4 per cent. The table below shows the cash flow and cumulative cash flow in constant year zero dollars. In year zero \$28,000 is taken from capital reserves to pay for the project.

### Constant dollar value – capital reserves

Year	Energy savings constant \$	Net annual cash flow constant \$	Cumulative cash flow constant \$
0	00.00	-28,000.00	-28,000.00
1	5,653.85	5,653.85	-22,346.15
2	5,708.21	5,708.21	-16,637.94
3	5,763.10	5,763.10	-10,874.85
4	5,818.51	5,818.51	-5,056.34
5	5,874.46	5,874.46	818.12
6	5,930.94	5,930.94	6,749.07
7	5,987.97	5,987.97	12,737.04
8	6,045.55	6,045.55	18,782.59
9	6,103.68	6,103.68	24,886.26
10	6,162.37	6,162.37	31,048.63

This analysis indicates a positive cumulative cash flow in year five. There is a net positive cash flow in all years after year zero, when the project was totally paid for.

Consider the following example, which is simplified to deal in current year dollars and does not take inflation nor opportunity costs nor return on investment into account.

In reality this simplified analysis is the way most rink and arena operators and managers would analyze an investment. The example looks at borrowing money for the project from a financing institution that requires a payment of interest on the money borrowed.

It assumes that the owner borrows 80 per cent of the \$28,000 investment in the previous example, at 12 per cent interest, 5 per cent escalation on energy, and \$5,600 annual savings. The current dollar value of this investment can be represented in the following table. The dollar values represented are not discounted to constant dollars.

### Current dollar value

Year	Bank payment current \$	Energy savings current \$	Net annual cash flow current \$	Cumulative cash flow current \$
0	5,600.00	00.00	-5,600.00	-5,600.00
1	6,213.98	5,880.00	-333.98	-5,933.98
2	6,213.98	6,174.00	-39.98	-5,973.96
3	6,213.98	6,482.70	268.72	-5,705.24
4	6,213.98	6,806.84	592.86	-5,112.39
5	6,213.98	7,147.18	933.20	-4,179.19
6		7,504.54	7,504.54	3,325.35
7		7,879.76	7,879.76	11,205.11
8		8,273.75	8,273.75	19,478.86
9		8,687.44	8,687.44	28,166.30
10		9,121.81	9,121.81	37,288.11
<b>TOTALS</b>	<b>\$36,669.90</b>	<b>\$73,958.02</b>	<b>\$37,288.12</b>	<b>\$66,958.97</b>

Payments in year zero represent the down payment. In year three, the installation begins to show a positive annual cash flow. The cumulative cash flow is not positive until year six.

The table shows that to finance a \$28,000 purchase you paid \$36,669.90 to the bank, you saved \$73,958.02 in energy costs and therefore saved a total of \$37,288.12. All values are in current dollars.

Thus, in looking at both capital funded and financed project funding, the cumulative cash flow was not positive until year five or six.

# 4. The building envelope

Energy needed to heat and cool buildings depends on two major factors. The first is the building envelope – roof, walls, windows and doors and floor of the building. The second is the installation and operation of the mechanical and electrical equipment of the building to provide a proper indoor environment.

This section explains how the building envelope affects energy consumption.

## Components and systems

The building envelope includes all the components that make up the shell of the building: the roof, walls, windows and doors, floor, basement walls, seals and joints between different components.

The function of any building is to provide heated or cooled space away from the wind and the weather. The building envelope is what separates you from the wind and the weather outside. It is your job to see that it does this in the most cost-effective and energy efficient manner possible.

Each part of the building envelope has at least four basic layers. These are the layers that have to be improved to reduce energy consumption. The four layers are as follows:

- air barrier;
- insulation;
- cladding, or the waterproofing for roofs;
- vapour retarder.

You should deal mainly with the first three systems to reduce energy consumption, although you will probably find it is easy to incorporate a vapour retarder, as we point out later in this section.

It is especially important to control air leakage because it affects the performance of the building in many different ways. For example, if you install extra insulation without first stopping all leaks, you will probably start or increase a problem of moisture accumulation in the walls and ceiling.

## Air barrier

Uncontrolled air leakage through the building envelope is typically responsible for up to a third, or even more, of the total heat loss of smaller buildings. An effective air barrier layer is achieved by a system of several components.

Air leakage out of the building is called exfiltration and air leakage into the building is called infiltration, but the common term to describe both is simply infiltration.

Air leakage can affect moisture accumulation in the walls and ceiling, and temperature control inside the building, as well as energy consumption.

Your building has an air barrier system to reduce uncontrolled air leakage. The air barrier is a critical component of the building envelope, because it is literally what separates the indoors from the outdoors. Because heat loss due to air leakage is a high percentage of your energy dollars, you should retrofit your air barrier before tackling anything else.

Heat loss from a typical building.

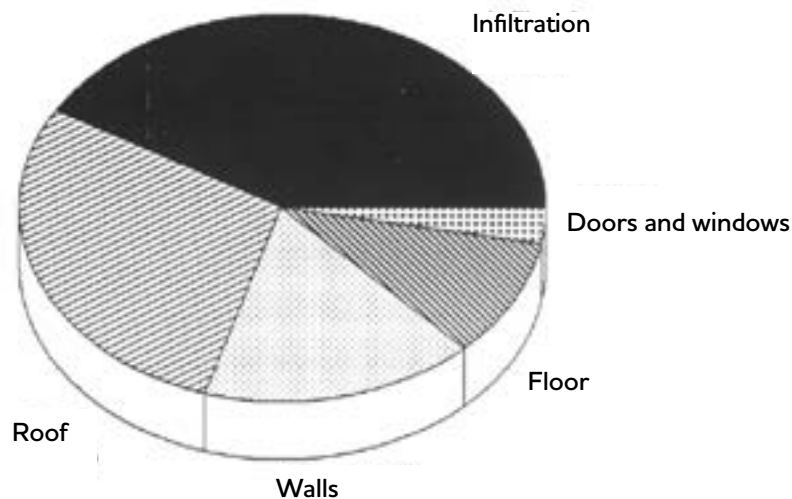

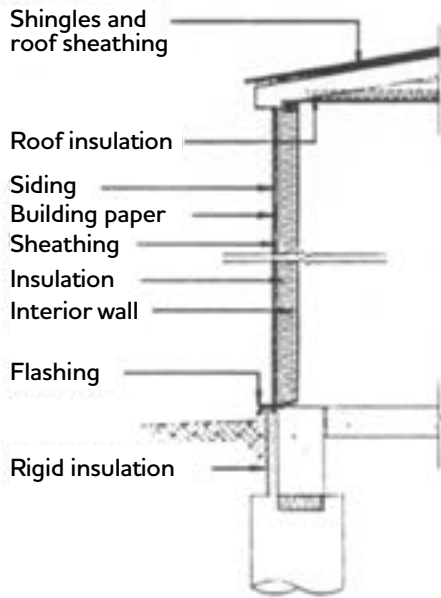

Typical stud wall construction.

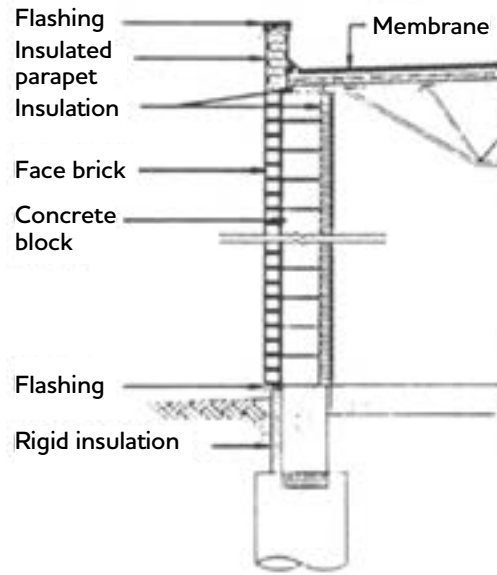

Typical brick and block wall construction.

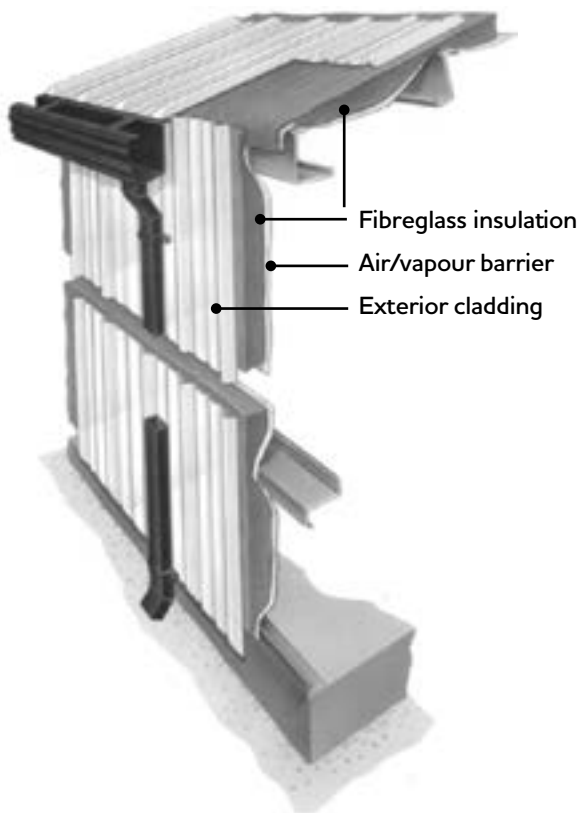

Conventional metal building with blanket insulation compressed between the girts and the outer skin.

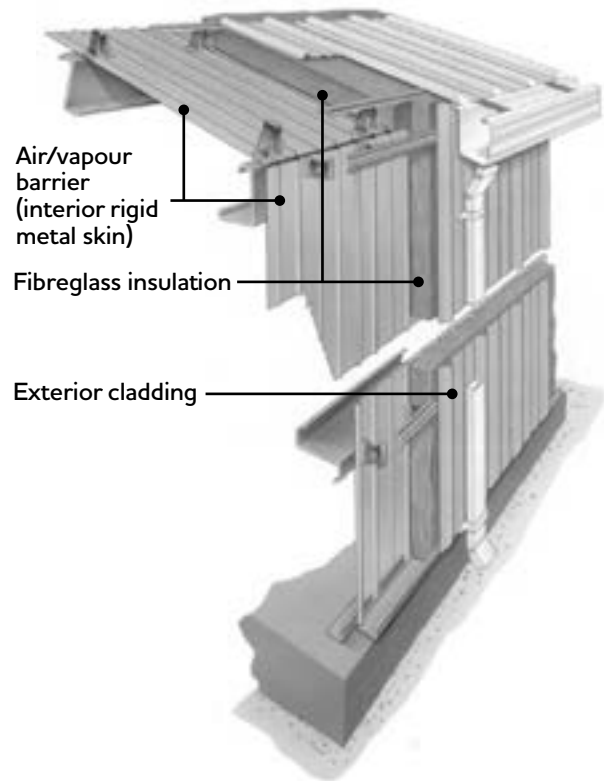

Energy efficient metal building. Standoffs between the interior metal liner and the exterior metal skin keep the insulation sandwiched in between from being compressed. The metal liner also serves as an air/vapour barrier.

## Materials to use

Strictly speaking, an “air barrier” is not something you can simply buy from a store and apply to a building. You have to build up an air barrier system during the construction or renovation of a building.

Many different materials in an arena become part of the air barrier system, as long as the materials are reasonably impermeable to air leakage. Drywall, plywood, concrete, and many common construction materials are relatively impermeable to air leakage.

Leaks can be sealed with tapes, caulking or gaskets, as for instance, gaskets around electrical switches and outlets. You can now buy many different types of caulking and tapes which are suitable for a variety of purposes and types of building materials.

Remember to ask is if the caulking will set up like rubber or a compressible gasket. You don't want to have the caulking still “liquid” when it's supposed to stay in place for a long time.

Materials like acoustic sealants are NOT good for this purpose because they don't set up and are very messy. Materials like silicones, polysulphide, and urethanes are better suited. Another question that should be asked is how the caulking stands up to the cold and moisture of a rink or arena.

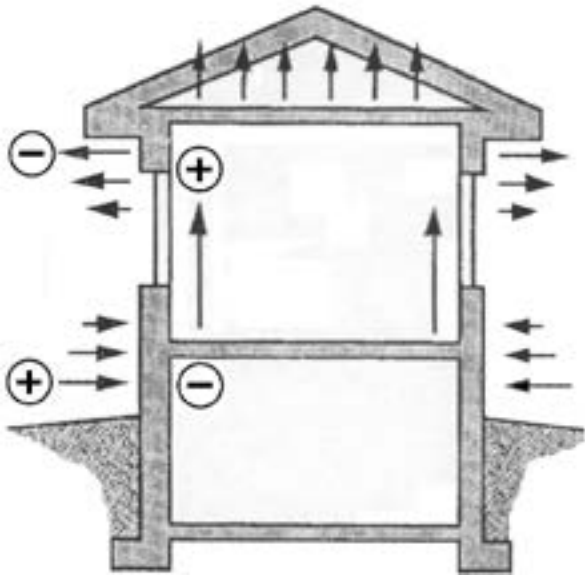

Leakage in a building caused by the stack effect. Air is drawn into the bottom half of a building to replace air leaving through upper half.

Do not use caulking that will quickly become brittle and crack or shrink, as it will lose its effectiveness. Make sure to use nontoxic sealants in sensitive areas such as kitchens.

## Where to seal

Leaks occur at joints between components, cracks in materials, and openings such as electrical boxes.

When you find a leak in a wall or ceiling you will probably find there are several layers of construction. Find the layer that makes up part of the air barrier system.

If you seal the wrong layer of construction you won't stop air leakage but only direct it through some other crack or opening.

For example, if you find a leak at an electrical box in a building that was sealed using polyethylene, it may not do you any good to seal the drywall. Air will still leak through the poly and past another crack through the drywall, at the floor for instance. For some penetrations, the fixture penetrating the wall or ceiling may move in relation to the wall.

To fix a leak then, the first thing to do is figure out where the leak is best sealed. What else is making up the air barrier? What should you use to build up the air barrier?

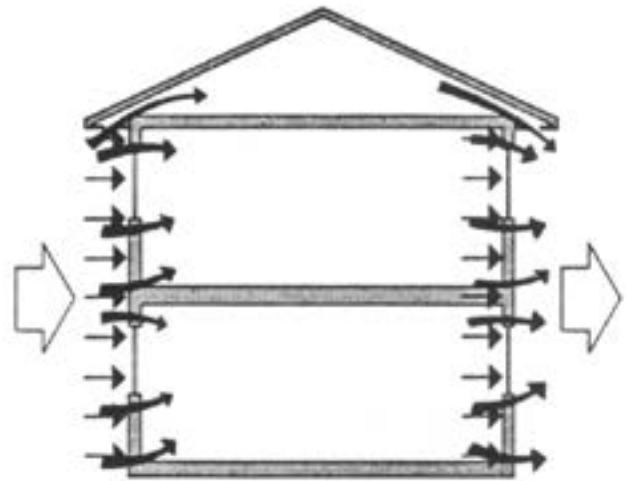

Leakage through a building under the effect of wind. Leaks develop at joints between components, through cracks in materials, and through openings such as electrical boxes.

Usually the easiest element to convert to an air barrier will be the building's interior finish which can easily be caulked and repaired. Pay special attention to the details of the building, such as corners and joints with the ceiling and floor or partitions, to make sure there are no leaks.

If you are using something inside the wall to make it airtight, like polyethylene or another membrane, consider the following four points before you start:

- The air barrier membrane must be continuous throughout the whole building.
- The air barrier must be fastened to the structure so it can resist high wind loads – inward and outward. Deflection of poly between studs must be kept to a minimum to avoid tearing.
- The air barrier membrane must have the same life expectancy as the building, or else you have to be able to repair it.
- The membrane should be in contact or sandwiched between solid materials on both faces to prevent movement and possible tearing. Being located between drywall or sheathings and insulating batts or sheets may not supply adequate protection.

These four requirements are important no matter what type of system you use.

### **Mistakes to avoid**

In recent years people have focused on “sealing the vapour barrier” when they really meant to “stop air leaks.”

This has worked for many cases, particularly wood frame buildings, but there are many situations where the vapour barrier has not remained sealed. The vapour barrier, or to give it its proper name the vapour retarder, may not be the best material to seal. It may not be strong enough to remain sealed after a prairie wind storm, or it may not be possible to seal it around structural braces or metal ties in metal buildings.

Polyethylene, a common vapour retarder, can be used in wood frame buildings where it can be stapled and held between the interior wall board and the insulation and studs.

For other types of construction it is best to use materials such as wallboard, plywood, metal liner panels, or reinforced membranes. There are many membranes such as PermaBarrier by Grace, TFM by Tremco, and other manufacturers' products which can be used to make an air barrier system for many types of buildings. Liquid applied membranes and sealants are becoming more readily available.

### **Ventilation**

Some outside air is required for indoor air quality and the comfort of occupants. This should be provided either by the building mechanical system or by vents or openings through the walls and roof of the building.

The fresh air can be heated or cooled as necessary, and part of the energy in the stale exhaust air can be recovered to lower space heating energy consumption. This is covered in the section on heating and ventilation.

### **Insulation**

Insulation is installed to control “heat conduction” through the building envelope. It is rated according to its resistance to conduction. This is commonly called its R-value (RSI in metric units).

If two different types of insulation have the same R-value, they will perform the same. There may be differences in the requirements for installation, or protection. One type of insulation may be more susceptible to moisture or some other hazard. But there will be no difference in thermal performance if each is installed and protected according to the manufacturer's instructions.

Other factors such as durability and cost should be used to determine preferences for insulation purchases.

### **How much is enough?**

Energy loss is inversely proportional to the R-value of the wall or roof or floor. The higher the R-value, the lower the heat loss. This has important implications when determining how much insulation is sufficient in a building, as the following example shows.

Suppose a wall has been built with an insulation level of R-10. We can reduce heat loss by 50 per cent by adding an additional R-10, for a total of R-20.

Upgrading the insulation from R-20 to R-30 reduces heat loss by another 16.7 per cent; from R-30 to R-40 by another 8.3 per cent, and from R-40 to R-50 by another 5 per cent.



Example of heat loss in dollars, as a function of insulation level.

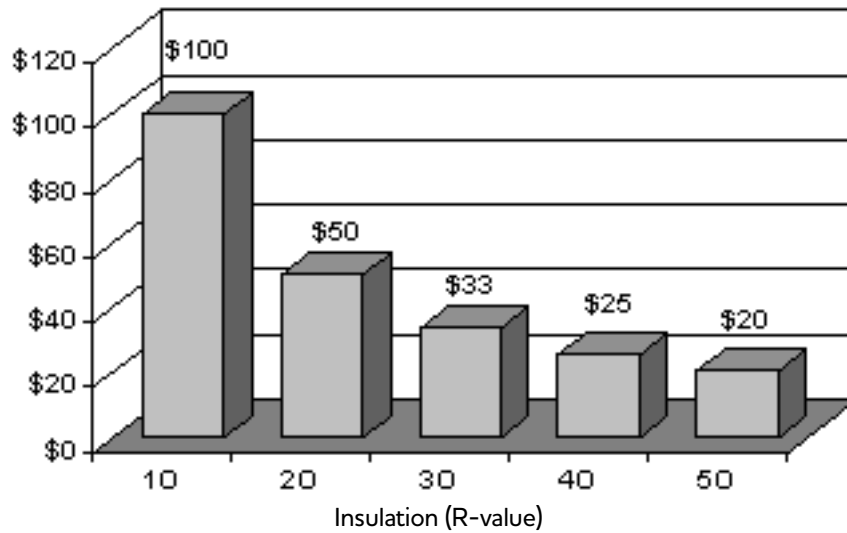

An example to show the economics of adding more insulation.

Each addition of insulation costs the same (disregarding the extra space that would likely be required) but clearly the value of each addition is not the same.

Some judgement or calculation has to be made to get the most economic level of insulation. This may be further complicated if the building requires not only heating, but a substantial amount of cooling, as for a rink operating in the summer months. You should also take into account the type of heating you have.

Wood or metal studs, steel columns, beams, girts, and ties all have lower R-values than the insulation. As a result they act to partially short-circuit the value of the insulation. In a building with bulky metal girts or beams coming through the walls and ceiling, you will not get full value for any extra insulation you install in the wall or ceiling cavity. The girts or beams will limit how much insulation is economical to put in the wall, or they may make it more effective (although also more expensive) to put insulation elsewhere on the inside or outside of the wall.

### Installation

Insulation must be held in place in walls and ceilings so that it is not blown out by the wind or shifted if the polyethylene billows. If you are using fibreglass or other types of batt insulation, be careful not to compress the batts too much. If you do so you allow air to circulate in the wall or ceiling cavity and short-circuit the insulation. All types of insulation must be carefully cut and closely fitted around protrusions, like electrical boxes or structural supports. Insulation should always be placed tight against the air barrier system, as outlined in the previous section.

Mistakes sometimes made when installing insulation.

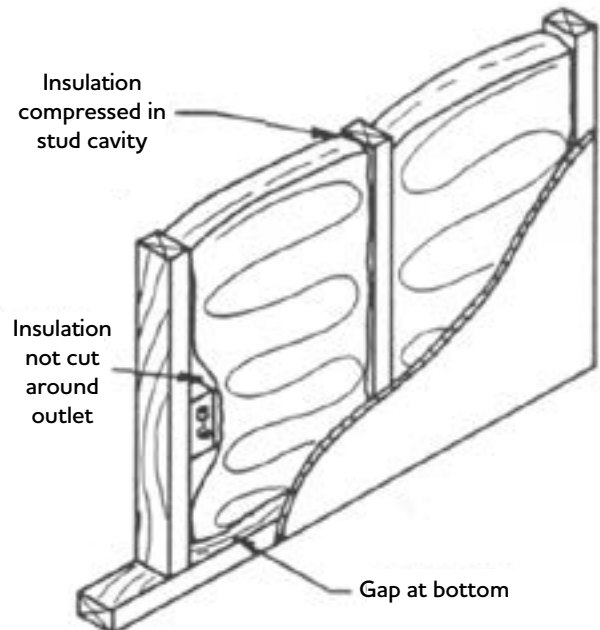

## Cladding

The cladding of the building protects interior elements from weathering and exposure to sun and rain. Normally this requires protection against wind gusts, sometimes with a type of building paper.

The cladding itself need not be sealed. In fact it is best to leave it unsealed so that any water trapped inside the wall can drain to the exterior. This is exactly what happens with hardboard, vinyl, or metal siding. Some cladding systems, like brick or stucco, have weep holes purposely drilled through the exterior to allow moisture to drain. These must not be sealed.

## Roofing

Membrane systems are commonly used on flat roofs, but strictly speaking, you should not allow a roof to be built totally flat. The more slope the less chance there is for ponding of water on the roof which can eventually lead to leaks and further damage.

Membrane systems installed in the conventional manner, over the top of the insulation, are subject to deterioration due to traffic and extremes of temperature and solar radiation. If you have this system, generally referred to as a built-up roof or BUR, and must access the roof for equipment maintenance, consider built up walkways. However, BURs are fairly easy to repair.

A more recent innovation is an inverted roof system, which places the roof membrane under the insulation. Many insulation companies and roofing suppliers can provide one of these systems. A ballast of gravel or paving stones is often used to hold the insulation in place. Some roofing products have a concrete layer bonded to the top of the insulation to hold it in place. As a heavy system, this is not typically a retrofit option.

## Vapour retarders

Vapour retarders or, as they are still commonly called, vapour barriers, are sometimes thought to be the only defence against air leaks. This is because polyethylene is often used in housing to provide airtightness, but it is not true that poly is the only defence or even the best defence against air leaks.

However, a vapour retarder is still needed on the warm side of the insulation. This can be poly or even two or three coats of an oil-based paint (not latex) or a vapour barrier paint.

Note that if the building uses drywall, plywood, or some other system to stop all air leakage, it is not absolutely necessary to seal the vapour retarder (see section on air barrier systems).

*Conventional built-up and inverted "flat" roof systems.*

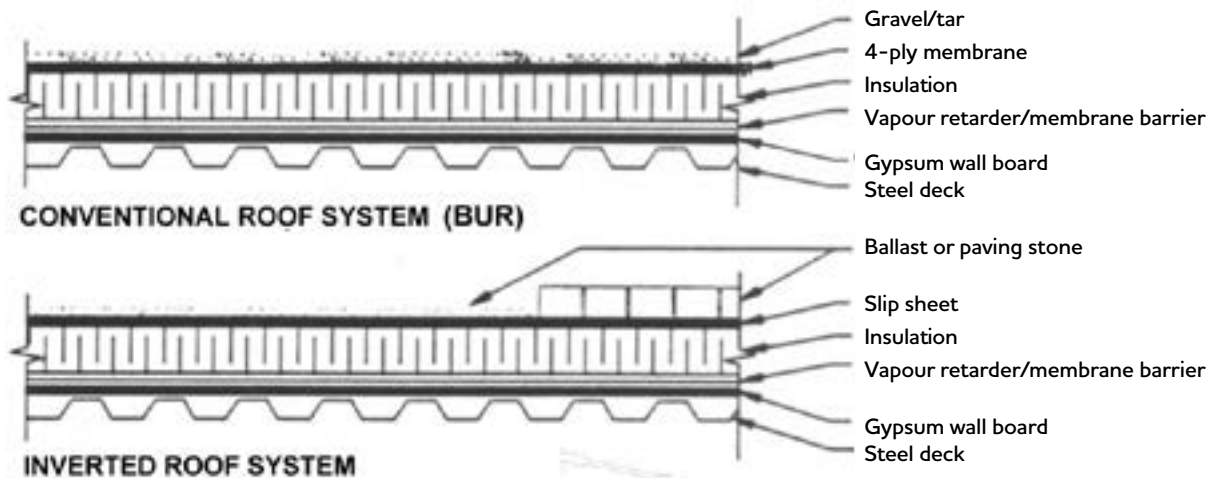

## Moisture problems

Moisture problems in rink and arena buildings can cause energy losses as well as deterioration.

### Energy

If buildings have an enemy it can be defined in one word: moisture.

Moisture affects the thermal performance of the building envelope by reducing the resistance of insulation. Only a small amount of moisture in the insulation cuts the R-value significantly. This costs extra heating and cooling dollars.

Moisture problems are often very difficult to discover in the first place, and may be even harder to track down and stop.

### Deterioration

Moisture that accumulates in the building envelope can lead to a variety of performance problems not directly related to energy consumption but more serious. This is especially true if the moisture attacks the building's structural integrity, such as when it rots structural members.

Moisture corrodes and rusts metal components in the wall. This may become an unsightly nuisance or lead to failure of some part of the arena structure. Replacing a rotted stud costs money, uses raw materials, and uses energy in production of the stud.

Frost and ice can also accumulate in spaces within the walls and ceiling of a rink or arena. Ice build-ups can cause deformation and deterioration of interior and exterior finishes. Icicles hanging from the outside of the building may be a hazard to occupants below. When the ice and frost melt in spring, some of the melt-water may run back inside where it is a nuisance and further hazard.

Masonry and brick buildings can suffer additional problems with moisture. Efflorescence is the white marking that often appears on these buildings. Caused by salt that makes up part of the bricks, it is deposited on the surface by moisture. Surface staining by other materials may also occur.

## How moisture accumulates in buildings

Moisture can get into the materials and assemblies of the building from the outside and from the inside. Outside is rain or snow and inside is humidity which can condense in the walls and ceiling spaces.

Moisture condensation occurs due to air leakage, for the most part, but also due to vapour diffusion, which is handled by the vapour retarder. Contrary to popular opinion, it is not absolutely necessary to seal the vapour retarder, because this will allow an increased amount of diffusion (a slow process) only over a small area. It is far more important to control air leakage, which may or may not be possible with the vapour retarder.

### Handling moisture

The most effective strategy is to prevent moisture from accumulating in the first place. However, almost all buildings have some form of moisture deposition or accumulation, and it is impossible to achieve a 100 per cent perfect building. As a result, there has to be some consideration for handling the moisture.

A number of approaches are used to minimize condensation in buildings, including some unique ones in rinks and arenas. In retrofit situations these basically involve reducing the amount of airflow through cracks and openings, reducing the humidity level of indoor air, or warming surfaces to reduce or eliminate the condensation.

To reduce the indoor humidity levels, try using ventilation fans to exhaust moist air from the building and bring in cold dry air. Heat recovery could be part of the ventilation to reduce energy costs.

Another strategy is passive ventilation using the wind to induce air flow through ducts and planned openings, or increasing natural ventilation through a chimney by increasing its size.

Preventing deterioration of buildings by controlling moisture is economical and conserves the environment. The building will last longer, and energy costs will not be incurred in the fabrication of the building raw materials.

## Wall types

The most common wall designs for new construction or renovations and additions, fall into one of only a few categories:

- wood or metal studs with drywall or plywood;
- precast concrete or sandwich panels;
- metal buildings;
- masonry with reinforced membranes.

These walls range from the expensive and durable to the inexpensive and temporary. They all include the four systems outlined at the beginning of this section—an air barrier system, insulation, cladding and a vapour retarder. Many of the problems associated with these designs happen at joints with other assemblies and at intersections with floors and ceilings.

### Studs and drywall or plywood

Drywall is one of the most common materials in construction, both for finish materials and as part of the air barrier system.

Isolate any openings, such as electrical outlets, to prevent air leakage at these points. Use rigid airtight enclosures around the electrical outlet, or eliminate penetration through the drywall or plywood by moving all services to interior partitions.

With metal studs, thermal bridges can develop between the interior and exterior faces of the wall because of the low resistance of the studs. Consider using exterior rigid insulation to make the cold side of the studs warmer.

Plywood can also be sealed on the outside of the stud system. The stud space can be used only as a service race for plumbing and electrical, and insulation placed on the exterior of the plywood. Any air leaks that develop could be difficult to seal, or even find. Ensure good durable construction and inspect the plywood joints before the stud system is enclosed. With this kind of air barrier system there are fewer seals between assemblies and usually fewer intersecting partitions.

### Precast concrete

Precast concrete is usually very expensive, but it also makes one of the most durable walls. You will be purchasing the whole wall as a system from a supplier or manufacturer. The wall will include all four systems mentioned at the front of this section. Anchoring systems for precast concrete panels, particularly large ones, are often widely spaced and have to be engineered by a consultant.

## Metal buildings

Metal buildings can be purchased in package form, and easily built up on site by local labour, with some assistance from the supplier or general contractor.

Pay strict attention to the air barrier. Many manufacturers use reinforced foil-backed insulation taped at the joints. This has almost always caused problems somewhere down the line when the tape becomes unstuck or the foil gets punctured.

It is best to mechanically clamp the joints together or to cover the foil with drywall, plywood, or metal and seal the covering layer especially in areas with high traffic or where the layer can be easily damaged.

Double gasket and sealing systems have been devised to join separate sheet metal panels. The technique includes sealing each fastener that penetrates the metal. Movement joints must be designed into any metal system placed on the exterior of the building.

### Masonry – reinforced membranes

Designs using masonry must accommodate the large amount of air leakage through such systems, and the movement characteristics of block and brick systems. Concrete block will shrink initially due to drying out of the material, and clay-fired brick will expand slightly as the brick absorbs moisture.

Techniques for sealing masonry or other infill panels use reinforced bituminous membranes. The membranes are usually applied as sheet materials, with a thick cross-section and reinforcing fabric between two layers of bitumen. They combine air impermeability and the ability to bridge gaps with increased strength and movement capability. Similar membranes are used in roofing.

Masonry buildings that are built in a single wythe or layer with insulation poured in the core of the block use enormous amounts of energy, because the insulation is not continuous and the walls tend to collect moisture that wets the insulation.

If you are retrofitting one of these buildings, consider the block as the structure only. You will still have to apply an air barrier system, a continuous layer of insulation on the inside or outside, and a vapour retarder. You will have to install either an interior finish (which could also act as the air barrier if it is properly sealed) or exterior cladding.

## Energy efficiency

Any building can be made energy efficient, but there are differences between the four types of buildings discussed above. Costs of energy efficient construction or retrofitting will be the biggest difference. They will dictate how much energy efficiency is economical.

The least expensive buildings to make energy efficient are generally wood frame buildings or buildings with studs and drywall or plywood. The cost of materials, including insulation, is usually lowest.

Labour can generally be provided locally and will be more familiar with this type of construction. As a result, labour rates may be less expensive and labourers more efficient on the job.

But there are downsides to this scenario. Such buildings are generally stick built on site and use traditional construction methods. Workers may not be aware of all the details of insulation or airtightness. Still with proper supervision, you can get a good building fairly inexpensively.

Precast concrete buildings are probably at the other end of the cost spectrum. They will be the most expensive to build and will be hardest to retrofit with insulation in later years. However, because they are so heavy and are manufactured and installed professionally, they can provide a very stable and comfortable indoor temperature and may also be very energy efficient if designed properly.

Metal buildings are fairly common and relatively inexpensive initially. Energy efficiency varies widely between different manufacturers, and even between similar buildings from the same supplier. Metal buildings are sensitive to the workmanship used in construction. Once complete they could be difficult to retrofit, depending on the complexity of structural components. Usually you should go back to the supplier or a competent consultant. Some newer designs can be very energy efficient.

In summary, masonry buildings can range from the best to the worst in terms of energy efficiency. If the building is a single wythe of block it will definitely require retrofitting. It may be fairly simple to do this by adding a membrane air barrier to the exterior, then extra insulation and a new exterior cladding. This would be quite expensive but it would complete all basic systems required for the building.

The building envelope may be a prime user of energy in your facility. To reduce energy consumption and improve the durability of your building it is essential to build in four basic layers: air barrier, insulation, vapour retarder, and cladding/waterproofing. These should be part of every building no matter what its construction.

In most cases where retrofitting is required, hire competent consultants to assist you in assessing your needs, determining possible solutions, estimating the economics of different options, and planning the final implementation of any retrofit.



*Parking lot controller with built-in circuitry.*

## Saving with parking lot controllers

Parking lot controllers slash your arena plug-in expenses up to 50 per cent, yet ensure trouble-free starts for staff or guests.

In contrast to earlier types of controllers, they save energy by automatically adjusting power at car plugs as a function of outside temperatures.

Above  $-5^{\circ}\text{C}$ , outlets receive no power. As the temperature drops, progressively more power is cycled to the outlets. Below  $-20^{\circ}\text{C}$  power stays on all the time.

Plug power is controlled either from a central panel or by circuitry built inside the receptacle – the so called “intelligent” parking lot controllers that use telltale lights to show if there is a problem with block heaters or cords.

# 5. Heating and ventilation

There are an unlimited variety of ways to heat and ventilate buildings. The choice of systems is based on a number of factors.

You need an energy source (electricity, natural gas, propane, fuel oil) and a heat transfer medium (air, water, steam) that flows through a heat delivery system (pipes and ducts). Typically we use air or water as our heat transfer medium because both are in abundant supply. The heat arrives in the room through grilles and diffusers or convectors, unit heaters, and radiators.

The exception is an infra-red or radiant heater which, like the sun, heats objects and people by direct radiation rather than through pipes or ducts.

Heat flow is always from warm to cool. The rate is based on the temperature differences between the hot side and the cool side and the resistance to flow created by walls, insulation, air films, and other building components.

The basic heating and ventilation system takes the heat from the heat source and distributes it to the places that need it, using fans and ducts for air-based systems or pumps and pipes for water-based systems.

## Furnaces

A furnace is a typical inexpensive heating unit. Furnaces are widely available using electricity, natural gas, propane or oil as a fuel source. Furnaces come in various configurations to suit various applications. They are inexpensive to own, operate and maintain.

Furnaces use air to distribute the heat to the rooms they serve. Furnaces rarely have capacities in excess of 200,000 Btu/h (60 kW).

Although furnaces are relatively inexpensive to operate and maintain, they suffer from the drawback that only one thermostat controls many rooms with different heating or cooling requirements. Furnaces are generally installed in mechanical or furnace rooms. Their efficiencies vary depending on type, operation, and the fuel they use.

## Electric

An electric furnace has an annual fuel utilization efficiency (AFUE) of 100 per cent. Essentially 100 per cent of the electrical energy supplied to the furnace is converted to heat in the building.

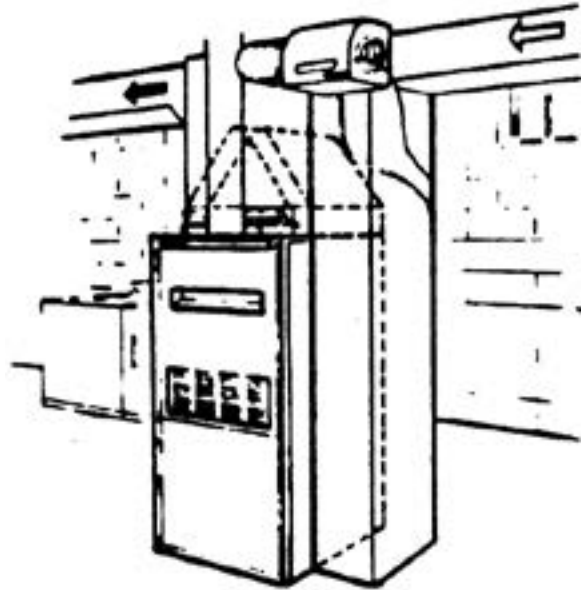

*Typical furnace*

## Natural gas/propane

**Standard.** A standard natural gas/propane furnace with a standing pilot has an AFUE of 55-65 per cent, despite a 75-80 per cent combustion efficiency. This means that only 55-65 per cent of the energy supplied to the furnace is realized as useable heat in the building. The AFUE is lower than the combustion efficiency because of the heated building air constantly flowing out of the chimney through the draft hood on the furnace. The efficiency is lowered further by the standing pilot that operates generally throughout the year (even though it may not be required for the entire year). Standard units are no longer available on the market.

**Mid-efficiency furnaces.** A mid efficient natural gas/propane furnace has an AFUE rating of approximately 80 per cent. The efficiency is improved over the standard furnace by replacing the draft hood with an induced draft fan. This eliminates the constant flow of heated building air out the chimney. The furnace also employs electronic ignition eliminating the standing pilot.

**High efficiency furnaces.** High efficiency condensing natural gas furnaces are very popular as replacements for old gravity vented furnaces.

The unit extracts at least 90 per cent of the available heat from the burned gas mixture. Efficiency is further enhanced over a mid-efficient furnace by utilizing a secondary heat exchanger. The secondary heat exchanger extracts the latent heat from the water vapour in the flue gases produced in the combustion process. The latent heat in the water vapour of the flue gases accounts for 10 per cent of the energy supplied to the furnace. The flue gases are then vented outside and the condensed water vapour is drained to a sewer.

High efficiency furnaces should not be installed in locations where the temperature may drop below the freezing point. There is a condensate trap on the furnace and the water in the trap could freeze. The furnace will not operate if the water in the trap freezes.

## Oil

Older standard oil furnaces have an AFUE rating of 60-70 per cent. This is due to warm air passing through the heat exchanger. Older heat exchangers offer little resistance to air flow, allowing room air to freely exit the building through the chimney even when the furnace is not operating.

Newer mid-efficiency oil furnaces are equipped with more efficient burners and offer more resistance to air flow when the burner is not firing. The AFUE rating of these furnaces is about 80-86 per cent.

High efficiency condensing oil furnaces have an AFUE rating of about 86-90 per cent. They are expensive and not commonly available.

## Radiant heaters

Infra-red heaters use a different principle than a furnace, unit heater, or boiler to warm occupants and rooms. The method is similar to sunshine or camp fires.

Radiant heaters use gas, propane or electricity to produce a high temperature radiating body. Heat is radiated via infra-red rays from the heater to any object "visible" to the heater. Since these heaters heat objects, not the air, they are sometimes advantageous in an arena application when you want to heat spectators in the stand but do not want to heat the rink itself. They may reduce heating costs since the air does not have to be heated to keep occupants comfortable.



*Radiant tube heat. Radiant heaters are very efficient at directing heat to the areas where it is required.*

Radiant heaters come in two basic types: high intensity and low intensity.

Low intensity heaters are generally radiant tube heaters. The combustion efficiency of low intensity heaters is about 80 per cent. The infra-red efficiency (amount of energy supplied to the heater that is transferred to infra-red energy) is as low as 35 per cent. As a result, 35 per cent of the energy emitted by low intensity heaters is infra-red, 45 per cent is convection, and 20 per cent is lost out the exhaust (vent).

High intensity infra-red heaters have an exposed burner that increases infra-red efficiency up to 80 per cent. Since the units are not vented, combustion efficiency is higher than for low intensity heaters. The heaters must be interlocked with an exhaust fan to ensure people are not exposed to harmful levels of carbon monoxide.

High intensity infra-red heaters generally require a high ceiling to accommodate the necessary clearances from combustible material.

## Unit heaters

Commercial unit heaters are a variation on residential style furnaces and are available in standard, mid, and high efficiency models. They are popular for heating large rooms with high ceilings.

A louvred diffuser on the discharge directs the air around the room. Generally no ductwork is installed on the unit. If ductwork is to be attached, the unit heater must be certified to be installed with ductwork.

Unit heaters are economical to install and easy to relocate, but have limited applications and do not provide for ventilation. They are not allowed in some buildings and some occupancies as a result of building code regulations. Unit heaters are not allowed in assembly occupancies such as meeting rooms or community halls. They are well suited for storage areas, garages, and work shops.

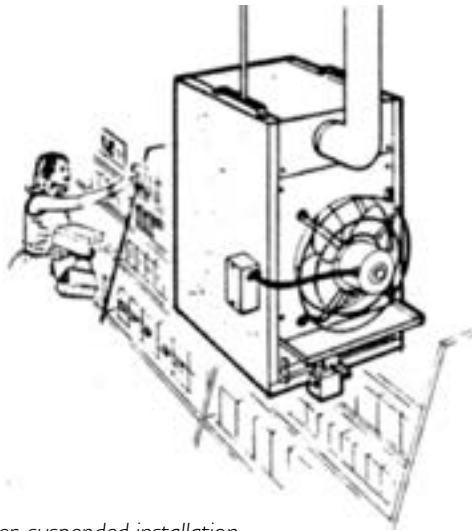

Unit heater, suspended installation.

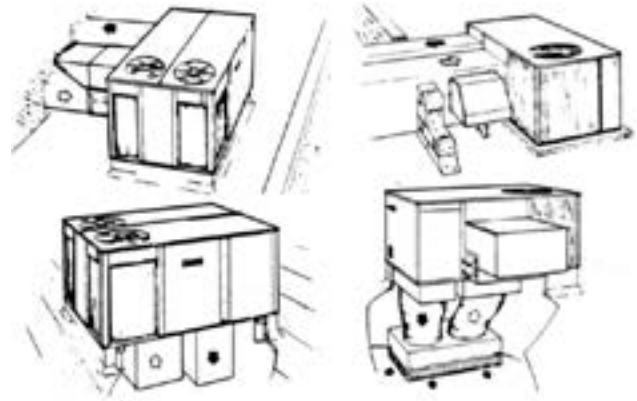

Typical applications of rooftop units.

## Air conditioners

In rinks and arenas, air conditioning is normally restricted to lounge and viewing areas in summer when outdoor temperatures and humidity exceed comfort levels. It can be part of a rooftop unit or built into a forced-air furnace system.

Air conditioners are rated in Btu/h. They may also be rated in tons, an old-fashioned term used to describe the cooling effect felt by melting one ton of ice in a 24-hour period. One ton of cooling is 12,000 Btu/h.

The efficiency of an air conditioner is expressed in two ways. One is the EER or Energy Efficiency Ratio, which is expressed as:

$$\text{EER} = \frac{\text{Btu/h cooling}}{\text{watts input}}$$

The second is SEER or Seasonal Energy Efficiency Ratio – essentially the EER averaged out over the entire season. The SEER is expressed as:

$$\text{SEER} = \frac{\text{Total cooling during season, in Btu}}{\text{total energy consumed, in watt-hours}}$$

In shopping for an air conditioner, look for a unit with a SEER of at least 10, or an EER of at least 9.0.

## Rooftop heaters

Rooftop units will have a seasonal efficiency rating between 60-75 per cent. The rating depends on the type of pilot, burner, unit location, cabinet insulation, and hours of operation.

As the name suggests, rooftop units put the equipment on the roof, freeing up valuable floor space. Rooftop equipment for general space heating is usually supplied with an air conditioning system, including ventilation.

Rooftop heaters with economizers use cool outside air instead of mechanical cooling to provide free cooling. When compared to furnaces with cooling coils, rooftop heaters use less electricity to cool your rooms.

Rooftop heaters distribute air through ductwork, normally above the ceiling. They cost more than a furnace but provide cooling and ventilation in a single packaged unit. Installation costs are lower or the same as they are for furnaces of similar capacity.



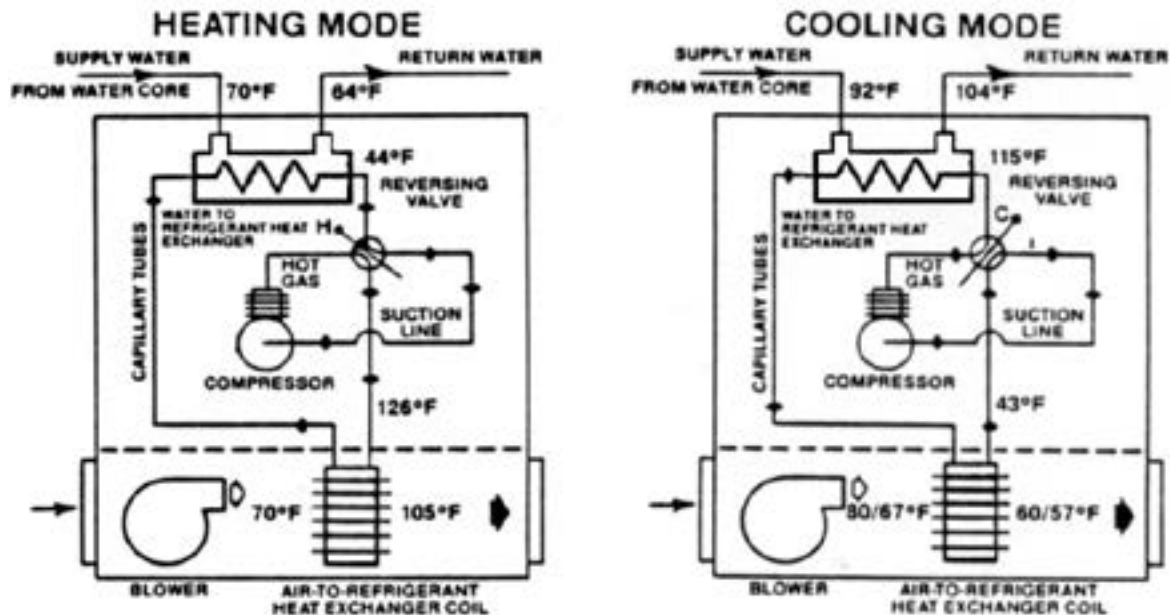

Heat pump showing both modes of operation.

## Heat pumps

A heat pump uses refrigerant circuits to move or “pump” heat from one location to another rather than using an electric heating element or burning fossil fuels.

Heat pumps can heat or cool depending on the requirement of the space they serve. Depending on whether the pump is in heating or cooling mode, an internal four-way reversing valve redirects refrigerant flow and reverses the function of the evaporator and condenser coils (a coil that absorbs heat in one case rejects heat in the reversed position).

Ground source heat pumps have coefficient of performance (COP) ratings between 2.5-3.5. As a result they can produce 2.5-3.5 kilowatts of heat energy for every kilowatt of electrical energy supplied to the unit.

Several new designs use an integrated heating and cooling system for rinks and arenas incorporating heat pumps with regular ice plant equipment to meet the space heating, water heating, and air conditioning demands of the complex.

For arenas these systems have a higher first cost (installed price) and lower operating costs than conventional systems.

Maintenance costs may be slightly higher than conventional heating systems but similar to air conditioning systems.

Heat pump systems can be used for space heating and cooling and water heating. Special care must be taken in the piping of the system to avoid fouling of the heat exchanger inside the unit.

## Hot water/steam systems

Central boilers can heat a building. The AFUE rating of older natural draft fuel-fired boilers is 45-55 per cent – slightly lower than the 55-65 per cent AFUE of a furnace. The difference is because of greater heat loss from the high temperature water stored in the boiler.

Newer boilers with electronic ignition and power vents or vent dampers have high AFUE ratings of 78-84 per cent.

Boilers can employ baseboard radiators, convection radiators, and coils in air handlers to transfer heat to the building via convection. Heat can also be transferred by radiation through hot water tubing installed in a concrete slab. A combination of all of these techniques can also be used.

In buildings with large concrete slabs and relatively low heat loss, radiant slab heating systems can be considered an alternative to other heating systems. Pipes embedded in the slab circulate hot water or use electric resistance heat to warm the concrete. The mass of the slab holds the heat in the floor for long periods and maintains the heat at floor level where it is needed. This is especially important in rooms with high ceilings where stratification can keep much of the heat high in the room and cause cool drafts at the floor.

Slab heating systems are well suited to heating lobbies and entranceways, viewing areas, and dressing rooms. A separate ventilation system may also be required to provide air flow.

Extreme care must be taken in the installation and long term maintenance of in-slab heating systems to ensure good operation. Improper care may lead to leaks and costly repairs since a large area of floor may need to be torn up to find one small leak.

It is important to install R-10 to R-15 insulation under the heated slab to reduce the amount of heat lost to the ground.

Slab heating systems have shown energy savings when properly installed because of the lower space temperature and lower ceiling temperatures possible while maintaining occupant comfort, due to the warm floor and occupant zones. Tubing can also be installed in spectator seating if it is a poured concrete slab. The technique further increases overall system efficiency since only the occupants are heated and the seating areas can be zoned, allowing for only certain sections of the seating area to be heated if the entire area is not used.

The installation cost of this system is much higher than it is for a furnace or rooftop systems, especially when the cost of the air circulation system is added to the cost of the slab heat and boiler system.

*In slab heating system.*

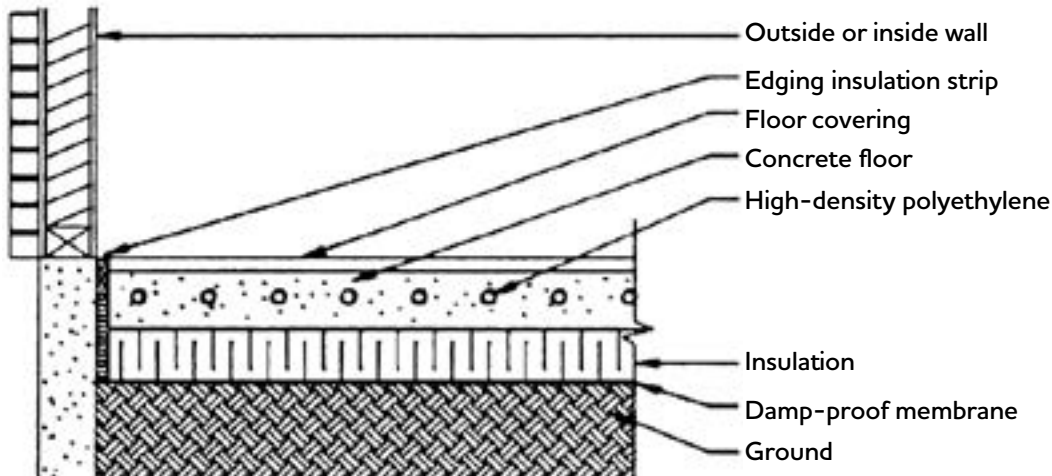

## Ventilation

Whether natural or mechanical, ventilation of buildings is critical for the health and safety of occupants.

### Natural ventilation

When an occupied room gets too hot we like to open a window to get some fresh air into it. This is an example of natural ventilation for thermal comfort. Outside air comes into the room through the window and cools off that area. It's intentional and we are controlling it. In warm weather we are saving energy by reducing heat gain through the walls and avoiding running cooling equipment. In cold weather, opening a window will increase the load on your heating system and cost money.

In rinks it is very common to ventilate the arena in winter to freeze the ice when a refrigeration plant is not in place.

Natural ventilation of a rink or arena in winter saves energy by reducing the run time of the refrigeration equipment in artificial ice facilities.

This is also covered in the following section.

### Health issues

Ventilation within buildings is very important for the health and safety of occupants. A table of suggested ventilation rates has been established by the American Society of Heating, Refrigerating and Air Conditioning Engineers (ASHRAE). The rate of ventilation is a function of activity, the number of people in the room and the odours associated with the activity.

For example the lounge in a curling rink can have a lot of people in a small space. There are drinking and smoking odours. Ventilation is required to dilute the odours and bring in clean fresh air for the occupants.

Arenas need ventilation. There are a number of cases where the carbon dioxide and carbon monoxide produced by the ice cleaning equipment was not removed properly and hockey teams were made sick by the vapour. Ventilation dilutes and removes those vapours and provides a healthy atmosphere for users.

Increased levels of activity accelerate the rate at which occupants are affected by these air pollutants. Essentially they are being deprived of oxygen necessary for activities such as skating, curling, and dancing.

Occupational Health and Safety standards have set acceptable maximum levels for carbon monoxide at 50 parts per million (ppm). Exposure above these levels may produce symptoms including cherry red lips and finger nails, reddening of the skin, headaches, giddiness, shortness of breath, faintness, or collapse.

Acceptable levels for carbon dioxide are recommended at 1,000 ppm. Exposure above these levels for extended periods may produce carbon dioxide narcosis. Symptoms include fatigue, headaches, stupor, and loss of sensation.

If you observe people in the rink or arena with the symptoms listed above, immediately move them outside into fresh air and administer oxygen if available. Keep victims warm and contact a doctor or transport victims to a hospital.

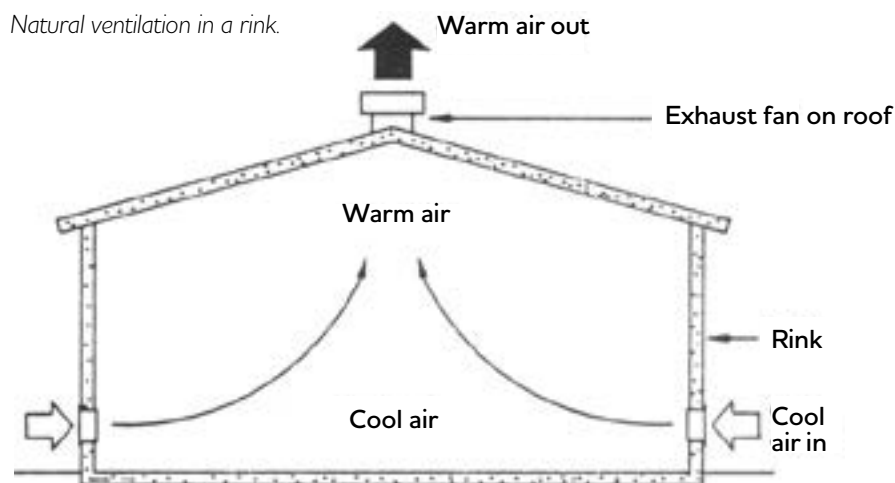

---

# Carbon monoxide safety

## *Guidelines for arena operators*

Carbon monoxide (CO) is a colourless, odourless gas that is released when heating oil, gasoline, diesel, propane, kerosene, natural gas, or wood burns without enough oxygen. Dangerous accumulations of CO can result from a faulty appliance, clogged chimney, inadequate venting, or a buildup of engine exhaust.

Manitoba Health recommends that arena operators observe the following guidelines to reduce the amount of toxic gases produced while the arena is in use.

- 1** Make sure the arena is well ventilated by fans, doors, and louvered vents. Turn on the exhaust fans, and open the doors and louvered vents before, during, and after the time when the ice-resurfacing machine is operating. To increase air flow through the arena, make sure the fresh air intakes are at the opposite end of the building from the exhaust outlet. Ceiling fans may help reduce the level of exhaust gases at ice level, so run them continuously.
- 2** Install three-way catalytic converters on ice resurfacers. Three-way catalytic converters reduce levels of hydrocarbons, CO, and NO<sub>2</sub>. Consider buying electric or battery-operated resurfacers, which reduce and in some cases eliminate concerns about air quality.
- 3** Warm up resurfacing machines outside or in a well-ventilated, specifically designed room; or attach a hose to the exhaust pipe to draw the toxic gases outside. Most vehicles must be warmed up for at least five minutes for catalytic converters to work properly.
- 4** Extend the exhaust pipe of the ice-resurfacing machine upwards so it is at least one foot higher than the top of the rink safety barrier. This will reduce the build-up of carbon monoxide and nitrogen dioxide at ice level.
- 5** Service the ice resurfacer regularly, according to the manufacturer's recommended schedule. Tune up at least after every 100 hours of use. Analyze the gas content of the engine exhaust to make sure the engine is properly tuned. Ensure catalytic converters are working properly.
- 6** Connect louvered vents electrically to exhaust fans so they operate at the same time. Exhaust fans can be set to turn on automatically to make sure they are used properly. Timers can be installed to control the operation of infrared heaters.
- 7** Open rink barriers while resurfacing the ice. This allows greater air flow across the resurfaced area, again reducing gas build-up. Make sure spectators and players stay clear of gate openings during resurfacing.
- 8** Install carbon monoxide detectors near the ice surface, and test them regularly. Consider testing the arena air regularly for CO and NO<sub>2</sub> to ensure gas levels are acceptable.
- 9** Levels should not exceed 25 ppm for carbon monoxide and 0.25 ppm for nitrogen dioxide. Test results exceeding these levels should trigger an immediate response to rectify the cause. See points 1 to 7, above. Arenas should strive to keep their exhaust gas levels as low as possible. Levels exceeding 125 ppm for CO and 2.5 ppm for NO<sub>2</sub> require that occupants leave the building immediately.
- 10** Any illness among skaters, regardless of the gas levels, should trigger immediate ventilation of the arena, a stoppage of skating activities, and a full investigation that involves the local Medical Officer of Health.
- 11** Make the arena a smoke-free environment. Cigarette smoke contains carbon monoxide.

## Mechanical ventilation

Use mechanical ventilation to remove vapours, heat, smoke and other air-borne contaminants. This produces a positive, measurable air movement in the spaces to improve indoor air quality and/or provide the desired room temperatures.

Rooftop exhaust fans are installed on arenas and rinks to help freeze ice in suitable weather conditions as well as remove smoke, heat, and possibly dust during indoor rodeos or dances held in the rink.

Lounges, lobbies, and kitchens use fans to remove smoke and odours in a similar fashion.

Ventilation costs can be significant. Operating a 1,000 cfm exhaust fan for 2000 hours (25 per cent of the time over one heating season) would cost roughly \$3,000 a year for electric or \$600 a year for natural gas.

## Heat recovery ventilators (HRVs)

An HRV is an air-to-air heat recovery unit that removes heat from warm, stale air being exhausted from a building and uses it to heat incoming cold, fresh air. The recovery of heat saves energy by reducing the load on the heating system. See “Heat Recovery” in Section 9 for more details.

## Heat reclaim

Up to 50 per cent savings in domestic hot water heating costs can be realized by installing heat reclaim on refrigeration equipment. Preheating of the water is relatively easy and produces water up to 90 F (32 C). The water heater only needs to boost the water to 140 F (60 C).

For a detailed discussion of financing and cost/benefit analysis, please see Section 3.

## Energy efficiency

Energy is defined as power multiplied by time. To reduce energy you must reduce the power or reduce the time you are using the power.

Reducing a heating thermostat setpoint maintains the same power requirement for that heating unit but reduces its run time. Similarly, shutting off motors reduces run time but does not change the motor power. Both actions take the same approach to conserving energy.

Adding insulation, reducing infiltration, and installing triple glazed windows are all examples of building envelope energy efficiency that reduces the energy requirement of the heating system. If, at the same time, some heaters are disconnected or a smaller furnace is installed, the power draw will be reduced.

**Setback thermostats.** During unoccupied hours, set back the thermostat on heating equipment to as low a temperature as is practical in most rooms. Normally 65 F (18 C) is cool enough to save 5-7 per cent of the heating energy but still allow for a quick warm-up before occupancy.

Spectator areas should be set back to 35 F (2 C) or cooler, except for games.

Be careful when setting back electric heating systems. Operating set back thermostats may increase your electrical demand if they control electric heaters and multiple units that all come on at the same time during warm-up.

**Time clocks.** Time clocks can be used to automatically setback thermostats, shut off ventilation systems, and shut off exhaust systems or other electrical loads when they are not required.

**Equipment efficiency.** When replacing equipment, install high efficiency versions.

The equipment itself consumes a lot of power. Firing efficiencies of boilers, furnaces, and unit heaters have a direct effect on the total energy bill. If a furnace is 80 per cent efficient, then 80 per cent of the energy to it is used to heat the building and 20 per cent of the energy is wasted. With high-efficiency condensing furnaces, there are no standing pilots or chimney heat losses. A 92 per cent efficient furnace puts 92 per cent of its input energy into the building and wastes only 8 per cent.

Electric heaters are nearly 100 per cent efficient; all heat ends up inside the building.

**Ventilation.** Shut down ventilation systems when they are not required.

Ventilation is required when a building is occupied. Heating outside air to room temperature can consume a lot of energy. By reducing ventilation rates during periods of low occupancy or shutting off ventilation during unoccupied hours, power requirements and the time required for heating are both reduced. The overall effect is lower energy consumption.

Ventilation systems are generally set up to bring in a minimum amount of fresh air. That air must be heated up to room temperature. If no one is in the area the heat is wasted. Shut off your ventilation systems during unoccupied hours. You can often accomplish this by wiring a switch, spring wound timer, or time clock to your ventilation controls.

Exercise caution when working with gas powered equipment in a building. Ventilate the building long after the work is completed to make sure that all products of combustion are exhausted or diluted. Contact the authority having jurisdiction to confirm appropriate ventilation rates and duration.

**Air traps.** Control the flow of natural ventilation in all areas.

In natural ice arenas, ice is sometimes created by bringing in sub-freezing outside air and exhausting warmer inside air. But at some point you may need to start heating the arena to provide a uniform climate for occupants.

This is particularly true in curling rinks where the air temperature is maintained at 35 F (2 C) while the outdoor air temperature can be -22 F (-30 C).

Air traps installed on air intakes allow good air flow into the space when you need it. The rest of the time they trap cold air and reduce uncontrolled infiltration.

Because cold air is denser than warmer room air, the cold air doesn't rise up the inside leg of the trap (see illustration) but remains trapped inside the duct.

When the exhaust fans start the air is easily drawn through the ductwork.

The same net effect can be created by equipping inlets with motorized dampers that physically shut off the opening. An air trap costs about \$300 installed.

A motorized damper of similar total capacity would cost about \$1,200.

**A look at maintenance costs.** It is best to install mechanical systems that are easy to maintain and operate. Systems that are neglected operate poorly and waste energy. It is very important to maintain mechanical equipment to ensure long trouble free equipment life, optimum performance, and minimum energy costs.

Furnaces, water heaters and electric heaters all provide simple reliable heat and are easy to maintain. Nearly every community has qualified people to operate this type of equipment.

Air conditioning equipment is somewhat more complex, but refrigeration mechanics are normally available within a reasonable distance of your community.

Highly sophisticated equipment and systems may be able to reduce certain energy costs but they usually cost substantially more to maintain. Specialists are normally required to provide maintenance for these systems at a cost significantly greater than the cost of a local volunteer.

*Typical air trap.*

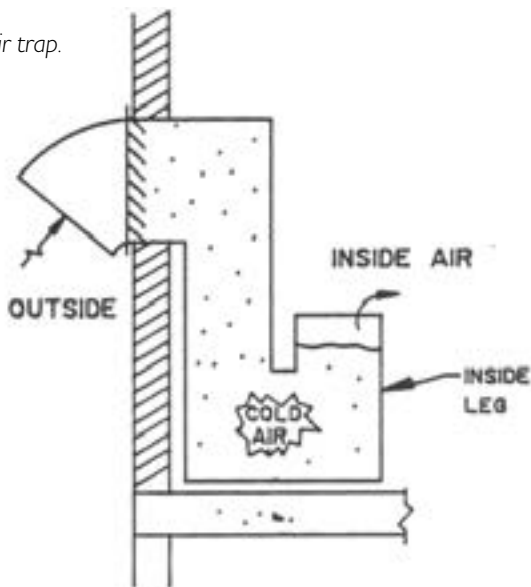

*Typical motorized damper.*

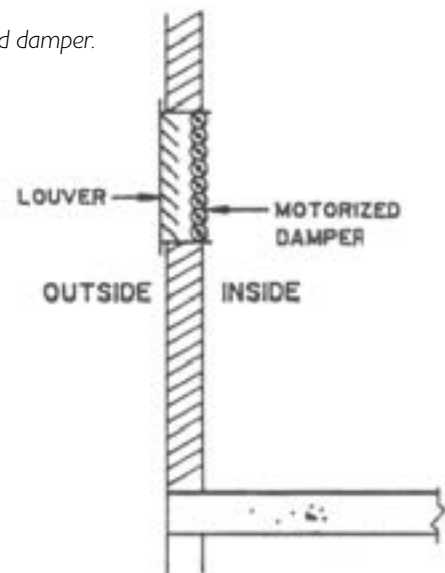

## Energy management

Here are a few basic concepts of good energy management:

### If you don't need it, shut it off

The most common and well understood energy management concept is: if you don't need it, turn it off. The concept applies to fans, exhaust systems, and ventilation systems.

Identify functions in your building that have limited use, for example, toilet exhaust fans in public washrooms. If the public areas are closed, shut down the washroom exhaust fans.

### Domestic hot water

Domestic hot water systems can consume 15 per cent of the total energy for the average arena. Hot water needs are well defined and seldom flexible.

Management of energy for domestic water heating falls into two basic categories, management of the source of heat and management of the stored heat.

Our choices for a heat source are:

- gas fired;
- electric;
- heat reclaim.

Most facilities choose gas heating or electric heat. The relative merits of each choice were discussed earlier in this section. Heat reclaim consumes the least energy but is offset by increased capital cost.

We can look at a number of ways to manage heated water. Once the water is hot, the idea is to keep it hot until it is needed.

Add insulation to storage tanks and pipes to hold the heat in the water and reduce stand-by loss.

Store hot water for flooding near the Zamboni room and shower water near the dressing rooms. A lot of heat can be lost in distribution piping. Examine the relative costs of each option carefully. Fill the Zamboni just before resurfacing to keep the water as warm as possible.

Another technique to avoid stand-by losses is to install an instantaneous gas-fired water heater which requires energy only when there is a demand for hot water. Since these units do not have a high storage capacity, stand-by losses are further reduced.

## Demand limiting

If you have chosen electrical heating for your domestic hot water heating or space heating system, your energy management strategy should include demand limiting.

A discussion of demand is included in Section 1. Demand limiting will save a lot of money by not allowing the heating systems to operate while the rink compressor is operating at full load. See also Section 6 for a discussion of demand limiting

In summary, the use of natural ventilation to freeze ice is very common and very practical. It saves on compressor run time and can be used in the summer to remove heat. Ventilation is critical in all areas of a facility, particularly in high occupancy areas like seating, dining rooms, and lounges.

Energy efficiency measures should include reviews of operating times and power levels of equipment being used. Time clocks, night set back controls, and equipment efficiencies all help reduce energy consumption.

Energy management involves the analysis and selection of operating schedules, efficient use of fuel, and informed choices on equipment and type of energy.

Rinks, arenas, and recreational facilities in general are often referred to as complexes. There is good reason for this. The facilities and the operating of the facilities is complex. The operation of one system affects the operation of another system and the net effect can be difficult to fully analyze or predict.

Operators must understand the often contradictory requirements of cost and comfort to satisfy the needs of the facility and the people who use it.

# 6. Refrigeration

This section deals with energy efficiency in refrigeration systems.

To appreciate the impact of energy efficiency measures, consider the total heat input to a typical rink before energy efficiency.

As the pie chart shows, radiant loads plus rink temperature and humidity can account for almost two-thirds of the total heat gain load on the refrigeration system in heated rinks.

Reductions in radiated heat loads, convective heat loads (rink temperature and humidity), brine pump work and ice resurfacing pay the most dividends because they are the largest of the loads on the ice plant. All other loads are minor in comparison.

The reductions, reflected in shorter run times for refrigeration equipment, save energy and therefore reduce energy charges.

To reduce electrical demand charges, you would need to modify the equipment in response to reduced system loads. These measures are also covered in this section.

The most important factor in reducing the cost of energy to operate an ice plant is to control ice making and ice thickness.

## Ice making

The sole function of the refrigeration system in rinks and arenas is to make ice. There are a lot of different things you can do to make ice: some are better than others, and some cost more than others. Here is some detail on ways to make high quality ice at the lowest reasonable cost.

## Slab

Construction of the rink floor is a critical element in the operation of the complex. A wide variety of floor constructions can be utilized depending on the building function and project budget.

**Slab Construction.** The flatness of the slab is of primary importance. Many rink slabs suffer from serious frost heaving and soil settlement due to sub surface moisture.

The floor in one corner may sit 2-3 in. (50-75 mm) below other points on the floor. During flooding the water runs to the low point, building up more than 3-4 in. (75-100 mm) of ice in that area and leaving only an inch (25 mm) of ice in the rest of the rink.

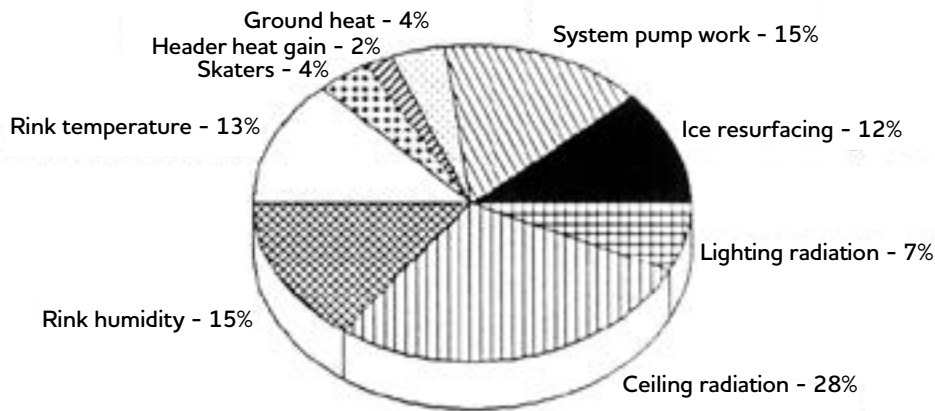

Heat loads on the refrigeration system. For a typical heated rink, radiant loads in combination with rink temperature and humidity account for almost two-thirds of the total heat gain load on the refrigeration system.



Because the ice plant has to work harder to keep the 3-in. thick section of ice cold, it overcools the rest of the ice surface, wasting energy.

**It is critically important to ensure that your rink slab is installed perfectly level and that it remains level throughout the years.**

Rinks with ice 12 months of the year do not require concrete slabs but must have heating installed below the slab—a heat deck—to prevent frost heaving.

Artificial ice rinks used for rodeos or as community halls in summer must have concrete floors but may not need heat decks. Rinks built on bad soil will probably require a structural slab to support the ice and avoid heaving or settling.

An all-purpose floor with subfloor heating allows for heavy loads, maximum flexibility, and year-round use depending on the scheduling of the facility.

The open or sand fill floor is the least expensive type of rink floor. It can be used in facilities where initial cost is a major factor and the floor is not intended for any other function.

To get the best value for the money spent on your rink floor, install a general purpose concrete floor so that other functions can be scheduled after the ice is removed. The floor should be designed to withstand average street loads and the cooling pipe installed in a reinforced concrete slab.

Thermal expansion and contraction of the slab must be anticipated and designed into the floor, particularly in facilities where the ice may be removed frequently.

**Sub floor insulation.** Install a minimum of R-15 insulation below the slab in facilities where there are quick change-overs, high soil moisture content, or if the rink will be operated continuously for more than nine months a year.

This level of insulation reduces the amount of heat absorbed from the ground, thus reducing the load on the ice plant. It also reduces the cooling of the sub grade and the formation of frost below the slab.

**Sub floor heating.** Testing has shown that rink slabs with 3 in. (75 mm) of sub floor insulation that are refrigerated for eight to nine months can create frost 2 to 3 feet (0.6 to 0.9 metres) below the insulation.

If there is no insulation, frost will penetrate 7 to 8 feet (2.1 to 2.4 metres) and usually cause heaving. In extreme cases, frost has been found 28 feet (8.5 metres) below ground.

To counteract the formation of frost in extended use rinks, install a heating system below the insulated slab. Circulating a 40 F (5 C) glycol/water mixture through the pipe network embedded in the sand base ensures a frost-free sub grade while adding very little extra cooling load to the rink slab. Control the pump with a remote-bulb thermostat installed under the slab to keep the sub-grade temperature above freezing.

The heat source can be rejected condenser heat or a separate gas boiler, electric boiler, or heat pump.

**Sub soil drainage.** Whether your rink floor is sand or concrete, the drainage of your sub soil is important. Frost heaving can only occur in the presence of sub-soil moisture, so if you can remove the water you should be able to avoid the problem.

Depending on the sub-grade condition, drainage channels should be installed below the rink to remove any water that migrates into the sub-base. Since every location has unique conditions, each drainage system must be designed by a qualified professional engineer or geotechnical consultant.

## Slab preparation

Start with a clean floor slab. Ice must bond to the slab to ensure good heat transfer.

Any impurities such as oil and dirt will affect the bonding of the ice to the slab. Other impurities will affect the freezing point of the water making it difficult to freeze the affected zones.

The refrigeration system must be capable of freezing the most difficult area of the ice surface. If you are keeping the rest of the rink colder than necessary, you are wasting energy.

## Water purity

The purity of the water used for flooding is critical to the quality of the ice produced. Any impurity in the water adversely affects the making of ice. The normal ions found in water disrupt the hydrogen bonding which normally occurs when water freezes. This creates ice that breaks up more easily.

Salts in the flood water lower the natural freezing point. Lower refrigerant brine temperatures are required to freeze the ice, using more energy.

Air in the water acts like insulation, making it harder for the brine in the slab to freeze the top layer of ice. Air can be removed from the water by heating it above 130 F (54 C). Such water is warm enough to bond with the base ice but not so hot that it imposes a huge load on the refrigeration system.

Consider the use of alternate water supplies if your present water source is high in impurities. Rain water sources such as roof run-off or dug-outs can be examined if practical.

### **Painting the ice**

Painting the ice a reflective white reduces the refrigerant load by five to 15 per cent compared to “dark ice.” Radiant heat energy from lights and heat is reflected away from the ice by the paint.

If the slab were the colour of dark sand or grey concrete, the heat and light energy would be more readily absorbed and would have to be removed by the ice plant.

Reflecting light back into the rink also reduces the amount and number of lights required to provide adequate illumination, for further energy savings.

Choose ice surface paints designed to be thermally conductive. Paints for lines and ice colouring, as in the case of all other impurities, reduce heat transfer through the ice.

### **Water purification**

If your water supply is bad it may pay to clean it up. Water high in iron, for example, produces a “coloured” ice that absorbs radiant light energy and puts an extra heat load on the ice plant.

Reverse osmosis water purification systems produce pure, demineralized water free of impurities such as organics, colour, bacteria and silica. Because pure water has a higher freezing temperature than softened water, brine temperatures can be raised. The ice produced is harder so less snow is produced and less ice surface maintenance is required. Pure water can be applied at a lower flood water temperature, which saves on heating and refrigeration energy. Less water is required for each flood, which means ice shaving isn’t required as often. This saves on equipment wear of the ice surfacing machine.

Generally hockey players, figure skaters, and curlers agree that ice quality is better for their sport when pure water is used.

Reverse osmosis machines are available from many water conditioning companies.

### **Ice thickness**

Keep the ice thin. One in. (25 mm) is considered optimum for energy efficiency. Because the ice acts as an insulator, excessive ice thickness will increase compressor load, for higher energy costs. The chart on the next page shows the relationship between compressor work and ice thickness for a hockey rink.

Note that ice 2 in. (50 mm) thick forces the compressor to run an extra 10 per cent and costs an estimated additional \$200/month.

Shaving ice is critical for reducing ice thickness and removing concentrations of impurities in the ice.

Ice sublimation, the process where ice turns directly to water vapour from the solid, reduces the amount of “water” in the ice, increasing the proportion of impurities. The impurities collect at the upper surface of the ice. If left uncontrolled the level of salts and minerals could build-up and put an extra load on the refrigeration equipment, as discussed earlier.

### **Ice melting**

If practical, take your shaved ice outside to be melted. Melting ice inside the building puts an extra load on the heating equipment.

The only exception is where condenser heat is reclaimed to melt the ice. Ice melting is covered later in this section.

### **Ice temperature**

Hold the temperature of the ice surface as high as possible. Hockey requires hard ice, figure skaters like soft ice, curlers want keen ice. Hockey rinks run with 16 F (-9 C) brine returning at 18 F (-8 C). Curling and figure skating ice runs with 22 F (-6 C) brine returning at 24 F (-4 C). Recreational skating is usually somewhere in between.

Each degree Fahrenheit that you raise the ice temperature reduces the load on the ice plant by up to 2 per cent. The drop is because of the combined effects of conductive, convective, and radiant heat loads on the ice surface. The higher the ice temperature, the lower the potential for heat transfer. See also the section on night setback for more on the practical application of this phenomenon.

### Mechanical refrigeration

“Refrigeration is the process of moving heat from one location to another by use of refrigerant in a closed refrigeration cycle” (ASHRAE Refrigeration Handbook).

Ice rinks and arenas use refrigeration to create ice for skating or curling. Refrigeration is a major financial commitment for any facility, in capital investment and the costs of energy and maintenance.

### The refrigeration cycle in rinks

Heat from flooding, lights, people, heating, equipment, the ground and the building is absorbed by the ice surface. The heat is transferred to the brine circulating through the floor. The brine is cooled in the evaporator of the ice plant. The compressor draws the gaseous refrigerant into its cylinders and compresses it. This raises the temperature and pressure of the refrigerant. The discharged gas moves to the condenser which rejects the heat from the brine plus the compressor heat.

Ultimately, all this heat is rejected through the evaporative condenser to the outside air. The gaseous refrigerant condenses to liquid. This liquid is expanded through an expansion valve before it enters the evaporator to cool the brine and complete the cycle.

*The thicker the ice, the greater the monthly cost to make ice.*

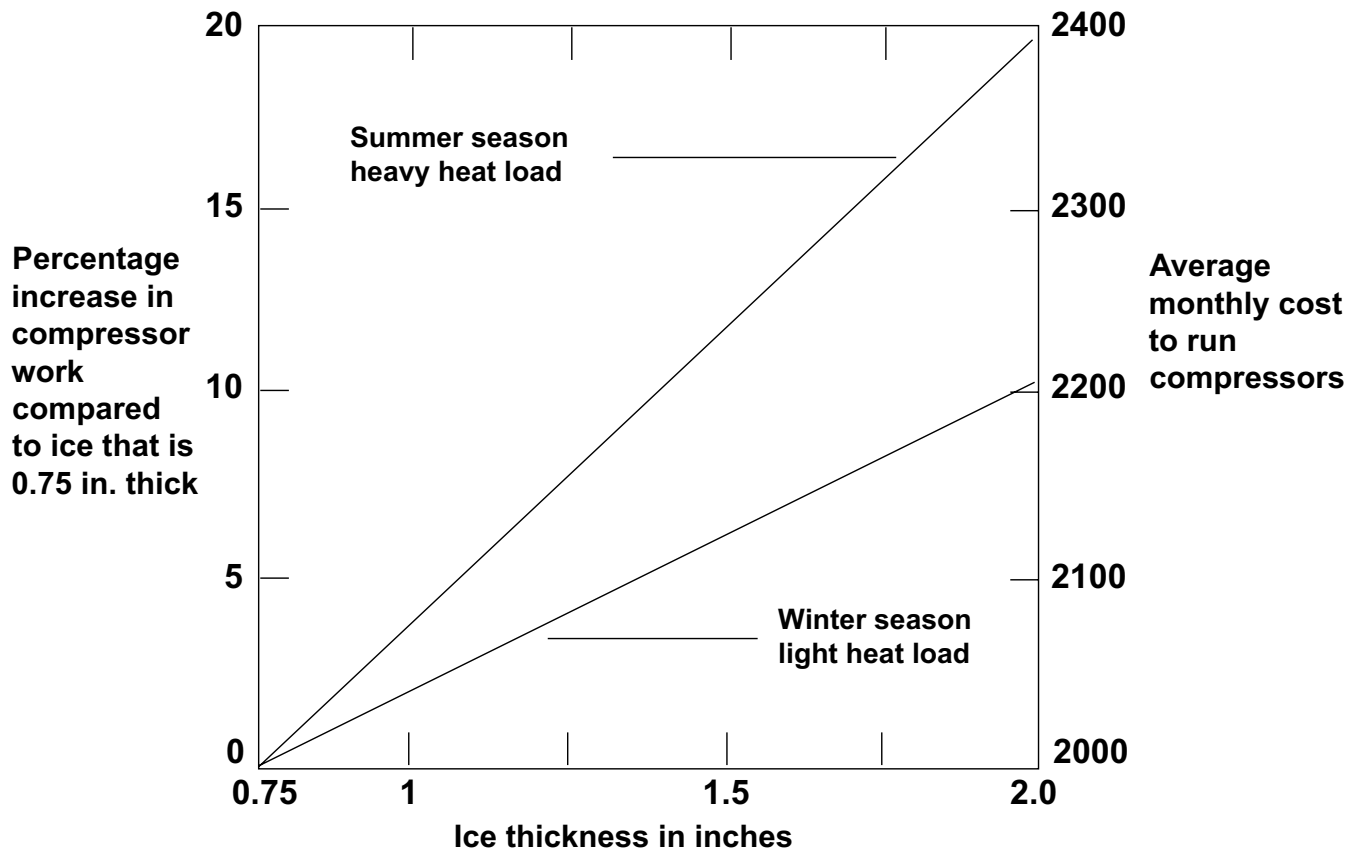

## Brine

Maintain your brine at a specific gravity of 1.20 to 1.22 for optimum energy use. Brine solutions, which consist of water and calcium chloride (CaCl<sub>2</sub>), are circulated in the rink floor slab to remove heat from the ice.

The brine must be maintained so its freezing temperature is always lower than the temperature of the refrigerant (ammonia, Freon) in the chiller, usually about -10 F (-23 C), but as high as possible. The lower the freezing point of the brine, the stronger the calcium chloride concentration, the higher the specific gravity. Higher specific gravity results in higher pumping horsepower.

### Brine specific gravity vs pumping horsepower required

Brine		Required pumping horsepower
Specific gravity	Freezing temp. (F)	
1.18	- 8.03	11.8 hp
1.20	-15.23	12.0 hp
1.22	-24.43	12.2 hp

## Variable brine temperature

Given that a higher brine temperature produces higher ice temperatures and lower refrigeration loads, maintain your brine temperature as high as possible.

Equipment is available to automatically reset brine temperatures based on a schedule of events throughout the day. A typical daily cycle may be as follows:

### Typical daily brine cycle

Period [24-hour clock]	Brine temperature	Rink function
0:00 - 6:00	25 F (-4 C)	Night setback
6:00 - 8:00	25 F (-4 C)	Ice maintenance
8:00 - 16:00	22 F (-6 C)	Low load
16:00 - 18:00	20 F (-7 C)	Figure skating
18:00 - 24:00	18 F (-8 C)	Hockey

Note that to drop brine temperature 2 F (1 C) takes only one to two hours if the ice is kept thin.

It is possible to save up to 8 per cent of compressor energy consumption when variable brine temperatures are implemented.

It is recommended that a separate slab sensor be installed to monitor slab ice temperatures if variable temperature brine controls are installed. This will ensure that the ice performs as required, independent of other loads on the system.

Refrigeration cycle

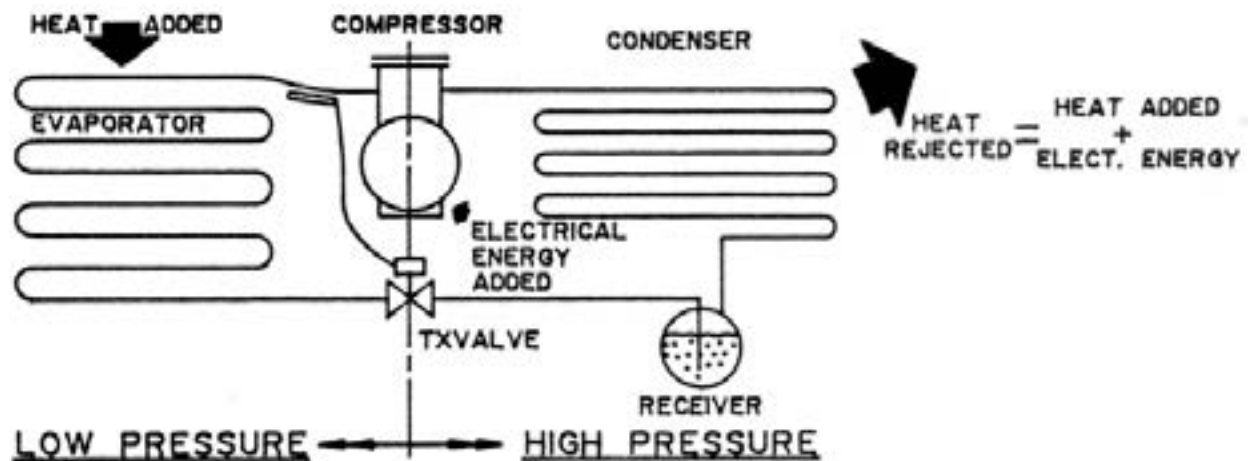

## Night shutdown

Night shutdown is an effective method of energy efficiency involving very little capital outlay.

You simply shut off your refrigeration plant at night, including the brine pump. All heat loads in the arena or rink should be shut off. Space heating must also be set back to 35 F (2 C). The ice temperature will rise slowly during the night. Once the slab sensor detects that the slab has reached 25 F (-4 C), the brine pump and one compressor should be started to prevent the ice from warming any further.

**You must use a slab sensor to restart the system since a brine return sensor will be ineffective while the pump is shut off.**

The soft ice in the morning will be easy to cut and groom for the new day. This reduces wear and tear on your ice maintenance equipment and saves on fuel.

Here is a key point to remember if you decide to use night shutdown or vary your ice temperature.

When the compressor is bringing the temperature of the ice down again, from 25 F to 18 F (-4 C to -8 C), keep the number of lights on and other pieces equipment operating to an absolute minimum to avoid setting a new peak demand.

If you fail to avoid a demand peak, you will still save energy but your demand charges could increase and cancel or overshadow any gains in energy savings.

## Variable speed pumping

Arena and curling rinks typically rely on in-line, centrifugal brine pumps to circulate a cold brine (salt) solution through the pipes under the ice.

Because the action of brine pumps introduce surprising large amounts of heat to the brine, major energy savings are available through improved brine pump control.

Brine pumps are typically 20 hp in arenas and 15 hp in curling rinks. They run typically 24 hours a day, 20 weeks a year.

Operating these pumps adds to your energy costs in two ways. One is the energy consumed by the pump itself. The other is that 90 per cent of the energy consumed by the pump appears as heat in the circulating brine, putting a large load on the ice plant compressor. Operating the pump is like running an 11 kW (15 hp) or 15 kW (20 hp) heater in the brine.

For example, most operators of rinks and arenas would not install a 15 kW heater in their brine loop, run it continuously, then pay to remove all that heat in the chiller. But that is effectively what they are doing when they leave their brine pumps running continuously, at full speed. A 20 hp brine pump puts 15 kW of heat into the brine loop in the form of friction in the piping.

To reduce this source of unwanted heating, consider applying one of the following three options for improving brine pump control:

### Brine pump cycling with an ice thermostat

This is the lowest cost option of the three. It involves installing an ice slab thermostat about 3–6 ft. (0.9–1.8 m) from the edge of the concrete slab. The thermostat allows the pump to come on only when the ice temperature rises above the ice thermostat set point.

This approach basically restricts the operation of the brine pump to the operation of the compressor. Once all cooling needs are met, all refrigeration equipment shuts down.

Of the savings achieved with an ice thermostat, about 87 per cent are from reduced operation of the brine pump. The remaining 13 per cent are from related compressor operation savings.

Using an ice slab thermostat reduces brine pump power by about 50 per cent because it reduces run time to 10-12 hours a day.

In a seasonal ice arena, yearly savings would be 34,000 kWh, which at \$0.03692/kWh would be worth \$1,255. This is an approximate cost, does not include taxes.

In a curling rink, yearly savings would add up to 15,000 kWh, which at \$0.03692/kWh would be worth \$554.

It costs an estimated \$2,500 to \$3,500 to install a slab thermostat. Payback would be two to three years for a seasonal ice arena, and five to six years for a curling rink.

**Two-speed/secondary pumping in combination with brine pump cycling with an ice thermostat**

Under this higher cost option, you would need to buy a new 2-speed pump or a smaller secondary pump that you would install in parallel with the old pump. If your old pump needed replacement anyway, this option would present an opportunity to install a 2-speed system.

You would also have to install an ice slab thermostat.

The basis for this option is that brine pumps are sized to deliver enough flow to satisfy peak cooling needs that occur only during warm weather operation. This means that either the 2-speed pump, or the smaller secondary pump, would operate most of the time on low speed for major savings.

Savings are roughly twice what they are with brine pump cycling because brine pump load increases/decreases with the cube of flow. A 50 per cent reduction in flow means an 87.5 per cent reduction in power consumed.

In a seasonal ice arena, two speed/secondary brine pumping would yield annual savings of 68,000 kWh, worth \$2,511 at \$0.03692/kWh.

In a curling rink, annual savings would add up to 30,000 kWh, worth \$1,108 at \$0.03692/kWh.

It costs an estimated \$5,000 to \$7,000 to install a slab thermostat and 2-speed pump. Payback would be two to three years for a seasonal ice arena, and five to six years for a curling rink.

**Variable flow pumping**

Another higher cost option, this one involves buying a new variable speed drive for the brine pump, as well as installing an ice slab thermostat.

As in the previous option, the basis for this one is that brine pumps are sized to satisfy peak cooling needs that occur only during warm weather operation. This means that for most of the time, a variable speed pump would operate the brine pump at a lower speed, for major savings.

Savings are even greater than for 2-speed pumping since the brine pump will operate at its optimum speed at all times.

In a seasonal ice arena, variable speed brine pumping would yield annual savings of 79,000 kWh, worth \$2,917 at \$0.03692/kWh.

In a curling rink, yearly savings would add up to 35,000 kWh, worth \$1,292 at \$0.03692/kWh.

It costs an estimated \$15,000 to \$25,000 to install a variable speed pumping system with slab thermostat. Payback would be five to nine years for a seasonal ice arena, and 12 to 19 years for a curling rink.

**Comparing efficient brine pumping system**

ARENAS			
	Cycling	2-Speed	VSD
Cost	\$2,500-\$3,500	\$5,000-\$7,000	\$15,000-\$25,000
Savings	1,255/year	\$2,511/year	\$2,917/year
Payback	2-3 years	2-3 years	5-9 years
CURLING RINKS			
	Cycling	2-Speed	VSD
Cost	\$2,500-\$3,500	\$5,000-\$7,000	\$15,000-\$25,000
Savings	\$554/year	\$1,108/year	\$1,292/year
Payback	5-6 years	5-6 years	12-19 years

## Brine line dehumidifier

Reduce your refrigerant load by reducing the humidity level inside your rink.

Some rinks use a clever method to accomplish this at minor cost. They set up a return brine line loop in a corner of the rink. Brine at 22 F (-6 C) in the line causes frost to form on the line, limiting the amount of water that can stay in the air to a 22 F (-6 C) dew point. A rink with a 35 F (1.7 C) space temperature will have a maximum relative humidity of 52 per cent, which is desirable.

A defrost cycle is required to melt the frost and drain the meltwater into a drain pit.

The cooling of water in the air of a typical rink accounts for up to 15 per cent of the total refrigeration load.

If humidity levels exceed the recommended level of 50 per cent R.H. the load increases significantly. Save energy by keeping humidity under control.

## Refrigeration dehumidifier

Some arenas use a refrigeration dehumidifier to reduce humidity levels in the rink area.

Working exactly like a free-standing home dehumidifier, a refrigeration dehumidifier removes moisture by cooling the air on cooling coils until the moisture condenses out. The water is routed to a drain.

## Controls

Adding controls to the refrigeration system can produce substantial savings in energy if the controls are carefully considered and well analyzed.

Control options run from inexpensive time clocks to specialized controllers to extensive computerized facility management systems. Under certain circumstances, some or all of these options may be appropriate for your facility.

## Switches

The simplest way to control equipment and save energy is to shut the equipment off when it is not required. All equipment has at least a disconnect that can be used, but the installation of switches, timers, and thermostats is recommended whenever possible.

The problem with switches is that somebody has to remember to switch the equipment off to start the savings, then somebody needs to restart the equipment to avoid a "melt down." Remember that your energy savings will be lost if the facility cannot be used as a result of bad management.

## Time clocks

Time clocks ensure that switching is automatic and savings will occur automatically on a pre-determined schedule. They come in various styles, including six-hour timers, 24-hour time clocks, and seven-day time clocks. Electronic, electric and electro-mechanical models are available to suit your control requirements.

Time clocks are well suited to night setback and night shutdown. Lighting and ventilation systems can also be controlled effectively in this manner. It is important to provide override controls in some cases, such as night shutdown of refrigeration equipment, to ensure that problems do not result from shutdown.

Critical functions should have safety switches that over-ride the time clock to avoid unwanted situations.

## Automatic controllers

Refrigeration control packages are specialized automatic controllers with multiple inputs to serve a specific function, such as a brine pump control. In this case the controller senses ice temperature and controls the pump according to the controller setpoint for the required ice temperature.

These controllers serve a single function that is independent of other system functions.

Costs vary from \$1,000 to \$20,000 installed, depending on the complexity of the function and the amount of power controlled.

## Computerized energy management systems

A computerized energy management system is the most sophisticated, most complex way to control your facility. This class of controls uses a personal computer control station and is capable of controlling the following:

- refrigeration system;
- brine pump;
- ice temperature;
- lighting and illumination levels;
- ventilation equipment;
- heating systems;
- other electric equipment;
- domestic water heating;
- demand functions.

They perform a range of functions, including:

- on/off switching;
- dimming and setback;
- thermostat adjustments;
- time of day scheduling;
- demand limiting;
- equipment monitoring;
- alarm functions.

Many computerized energy management systems are also capable of doing registrations, maintenance notices, inventory, accounting, bookkeeping, invoicing and security.

Cost generally starts at \$10,000 and can easily run up to \$30,000 depending on the complexity and number of control functions required.

This type of system is best suited for very sophisticated owners with large facilities and high energy consumption. The economic feasibility of this equipment must be carefully analyzed, with input from control system and refrigeration equipment specialists. Facility management should also look at other possible applications for the computer.

## Integrated systems

It seems unlikely but it happens every year. Evaporative condensers and heating systems run simultaneously throughout the winter. The evaporative condenser rejects heat to the outdoors while the heating system adds heat to the building or to water. The rink pays to run the evaporative condenser and pays for the heating energy.

Rinks and arenas with high energy costs are sometimes built with integrated heating and refrigeration systems that eliminate this waste of energy. A number of rinks in Manitoba have been built in the last several years with these systems incorporated into their plans.

In most cases the ice plant can remain as is. Two 50 hp compressors in the ice plant are used to produce chilled brine at 18 F (-8 C). The plant cycles on and off to meet ice-making needs.

In new construction it is wise to consider parallel refrigeration units comprising four, 25 hp machines. The strategy provides for an increased number of load capacity steps, redundancy in the system, and use of refrigeration compressors for summer air conditioning.

In either case for integrated systems, rejected heat is used for space heating, domestic water heating (or pre-heating), or any other heating applications.

Care must be exercised in the design of integrated systems. In very cold weather the ice plant rarely runs. If it is the heat source, you won't have any heating when you need it most. In spring and fall, the refrigeration plant runs almost continuously yet the need for heating is minimal. These situations point out the need for alternate heat sources and alternate heat sinks (heat rejection systems). Some facilities store the heat in insulated water tanks to be used at a later time. This is known as thermal storage.

Integrated heating and cooling systems are inherently efficient if they are well designed and controlled. But control of the system can become complex. The level of complexity should match the skills and knowledge of the operator(s) and the availability of qualified service personnel. In some cases, especially multiple parallel compressor installations, computerized controls are recommended for optimum efficiency.

The addition of heat pump units can create other interesting possibilities for providing a higher temperature heating source plus summer cooling. When integrated into a heat recovery system, savings in operating costs are possible. The savings must be weighed against the purchase price and maintenance costs.



## Alternate heat sources/sinks

Geothermal energy can be used as an alternate heat source or heat sink. Examples include the use of ground water and ground source heat loops.

Ground water loops circulate well water through heating/cooling systems and return it to a second well. Heat is added to the water (heat sink) or heat is removed from the water (heat source) as required.

Ground source loops circulate water or brine in a closed loop through pipes buried in the soil under the parking lot, ball diamond, etc. next to the complex. The ground loop can be used to chill rink brine if the soil is totally frozen. When connected to a heat pump, the ground source loops can be used as heat sources or heat sinks depending on the specific soil and ambient temperatures.

## Heat recovery

You can save significant amounts of energy by recovering heat from refrigeration equipment. Reclaimed heat from the condenser loop is generally used for:

- flood water heating;
- domestic water heating;
- space heating;
- under slab heating;
- ice melting.

An average of 25 tons (88 kW) of refrigeration heat is typically available throughout the day. As a result, up to 7.2 million Btu (2110 kWh) per day of rejected heat energy from the ice plant is available for other heating requirements.

The heat available may or may not be at a temperature that is useful for applications. Condenser heat is available at 95 F (35 C). Compressor discharge refrigerant is at 240 F (116 C) in a freon system.

Installing certain energy efficiency systems and modifications to the refrigeration equipment will change the total amount of heat available for heat recovery. Be sure to consider all measures in total before purchasing heat recovery systems.

## Flood water heating

Freezing flood water represents a large portion of the load on an ice plant. It makes good sense to heat flood water from reclaimed heat.

If rink flooding requires 600 U.S. gallons (2,271 litres) of water a day at 140 F (60 C), assuming a 40 F (5 C) inlet water temperature, then 500,000 Btu (146.5 kWh) is required to heat the water every day.

A heat exchanger can be connected to the discharge gas line of the compressor to heat the water with 240 F (116 C) ammonia or freon. A thermostat in the tank can cycle the water circulation pump to maintain water temperatures. It is important to size all equipment carefully and provide adequate back-up heating capacity if the compressor is not operating between floods.

Condenser heat can be used to preheat water but the relatively low water temperature limits the discharge temperature. The maximum discharge temperature for this system would be about 80 per cent of the temperature difference between the inlet domestic water temperature and condenser water temperature. Standard fuel fired water heaters would be required to provide 140 F (60 C) water for flooding.

## Domestic water heating

The total heating requirement is subject to wide variations based on the actual usage of your facility. For example, assume a daily consumption of 840 U.S. gallons (3,180 litres) of 120 F (49 C) water. This results in a total heating requirement of 560,000 Btu/day (164 kWh), based on an inlet water temperature of 40 F.

Since ammonia is a toxic substance, direct contact with potable water in a heat exchanger is not allowed. A specialized heat transfer unit must be installed.

Condenser heat is only practical for pre-heating because the highest discharge temperature would be about 90 F (32 C). Still, this would save about 63 per cent of the total energy required for domestic water heating. Standard fuel fired water heaters would be required to provide adequate temperature for shower water.

## Space heating

Heat reclaim is available for space heating but the quality of the heat is low grade. Heat pumps are now able to use this low grade heat to provide space heating and summertime cooling.

If compressor superheat is available from a freon refrigeration plant, there may be ways to produce 160 F (71 C) hot water to supplement boiler water heat. Relatively few facilities have hot water heating systems, so applications are limited except in new construction or major heating system renovations.

## Under slab heating

Extended use facilities install heating pipes below the insulated rink floor slab, as shown below.

Water circulated in the loop should be kept at 35 to 40 F (2 to 5 C) to prevent the formation of ground frost and heaving of the slab. Because of the low temperatures necessary, heat reclaim is an excellent source of heat for under slab heating.

The total heat required is 50 -100 MBH (15 - 30 kW) to prevent freezing of the floor foundation and frost heaving. The operating heat from a circulating pump is often enough. A small gas or electric heater can be installed to provide some heat if necessary.

## Ice melting

Melting shaved ice and snow from rink maintenance with a condenser heat loop saves energy in space heat and evaporative condenser operation. If it is impractical to take the snow outside, then heat reclaim is a good way to melt the snow in a drain pit.

Installing condenser heat coils or loops in a large drain sump provides a relatively constant temperature heat sink. Since water and ice can only co-exist at 32 F (0 C), the sump will be close to that temperature any time snow is in the pit. The system should be designed to melt snow at a rate equal to the maximum snow load expected.

Similarly sensors in the pit should stop the flow through the condenser heat loop if there is no snow to be melted. It is counter-productive to heat meltwater and add humidity to the rink.

*Typical configurations for hot deck piping.*

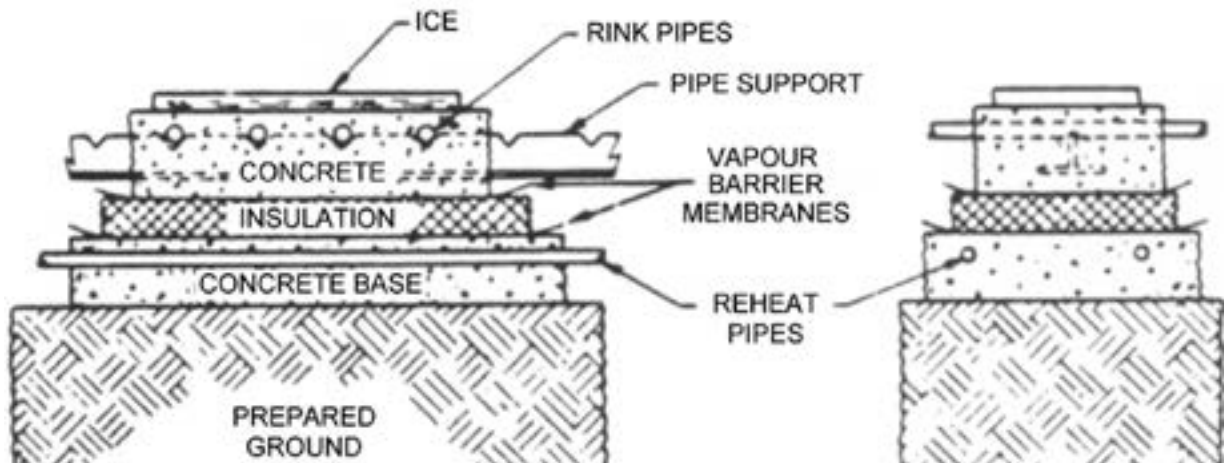

## Electrical

In most ice rinks and arenas, refrigeration system motors consume the largest amount of electricity. The motors, which vary from 1 to 100 hp, provide high quality ice in your rink.

### Power factor correction

Large electric motors over 25 hp (19 kW) should have power factor correcting capacitors. The capacitor bank must be sized to suit the specific motor power, speed, and frame size to avoid over voltages and torques. A detailed technical discussion of power factor correction is included in the appendices.

Power factor is the name given to the ratio of the usable power measured in kilowatts (kW) to the total power delivered measured in kilovolt-amperes (kVA).

Electrical systems with large electric motors can suffer from low power factors. Your demand charges will be higher than necessary for the actual work that is provided by your equipment.

In most rinks and arenas all major motor loads are in a relatively small area. It is best to install power factor correction capacitors at the motor terminals. This reduces the load on the distribution wires to that point. Over-current protection must also be adjusted downward accordingly to prevent motor burnouts.

Here is an example to show you how increasing your power factor correction helps you get more out of your electricity.

Power delivered: 100 kVA

Power factor improved from 80 per cent to 95 per cent

Reduction in power delivered is:

$$100 - (100 \times 0.80/0.95) = 16 \text{ kVA}$$

Savings: 16 kVA reduction at \$9.45/kVA saves

\$151/month or \$1,210 in an eight-month season.

To achieve the improvement in power factor in the example requires 34 kVAR. The cost of 34 kVAR of capacitors at the service entrance, including automatic switching, is an estimated \$3,400. As a result, the simple payback is:  $(\$3,400)/(1,210 \text{ per season}) = 2.8 \text{ seasons}$ . Check your own conditions to determine your requirement and your payback before proceeding. Rinks with shorter seasons have longer paybacks.

### Lighting loads

Reducing your lighting loads saves on your refrigeration load. Given the coefficient of performance (COP) of refrigeration equipment, one kilowatt of power delivered to the compressor removes 2.5 to 3.0 kilowatts of heat. As a result, each dollar of electricity saved in lighting saves an additional 34-40 per cent in the refrigeration system. See the section on lighting for ideas on reducing lighting loads.

### Motor selection

Energy efficient motors have efficiencies above 83 per cent, in all sizes from 1 to 25 hp as shown below. But the economics of replacing an operational old motor with a high-efficiency version are very poor and the payback period is long. Install an energy efficient motor when the existing standard motor fails.

*High efficiency motors help keep your power factor high and cut demand charges.*

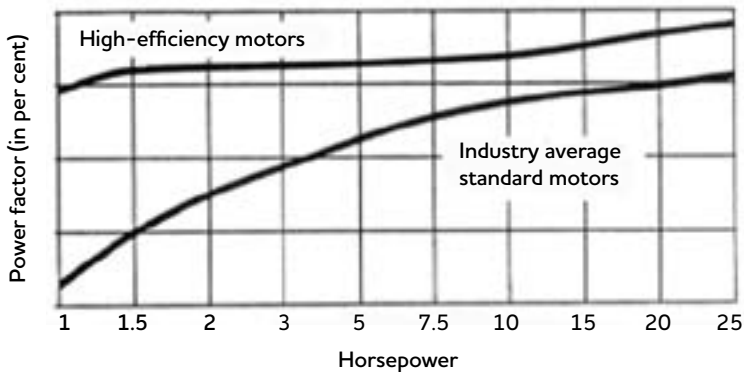

## Demand limiting

Consider demand limiting if your facility has large non-refrigeration electric loads such as electric cooking equipment, electric heating systems, or large air conditioning units (in year-round facilities).

When demand is peaking, control equipment shuts off or turns back these electric loads to reduce the peak demand for power.

Demand limiting equipment requires installation of meters and other devices to sense when new peak demands are approaching. Systems can simply warn operators or they can use computers to automatically switch loads on and off to maintain set demand limits.

From the viewpoint of demand limiting, it is a good idea to install two smaller independent refrigeration plants in new or replacement construction. One is sized to handle average loads and the other is sized to handle peak loads. One motor running fully loaded is more efficient than one large motor running half loaded. With two smaller independent refrigeration plants, you can limit demand at peak demand times by shutting one plant off. Capital costs are substantially higher with this method, but it saves energy over the life of the facility.

Costs of these systems can vary from a few hundred dollars for time clocks to several thousand dollars for more sophisticated computerized systems. Contact your Manitoba Hydro Energy Services Advisor, electrical contractors, electrical engineering consultants, controls contractors, or electric equipment suppliers for more detailed information about demand limiting costs and opportunities for your specific application.

*Effect of installing a ceiling curtain.*

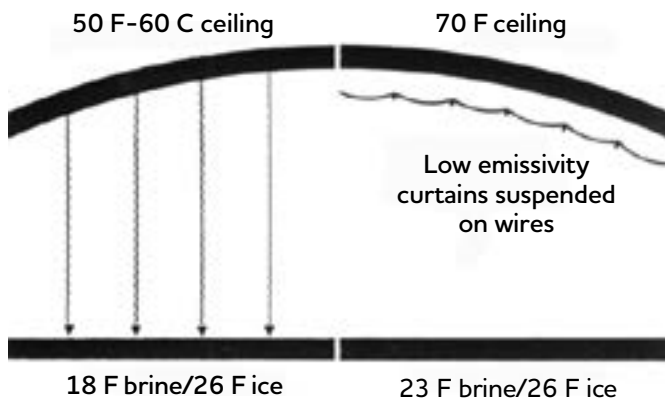

## Low emissivity ceilings

There are many factors such as the temperature in the ice area, the length of the operating season, the material used for the ceiling, the amount of insulation used in the ceiling and the actual temperature of the ceiling that affect the radiated heat load a ceiling places on the ice plant. As much as 28 per cent of the load on a refrigeration system in a heated rink can be attributed to the radiated heat from the arena ceiling.

Reducing the radiated heat load of the ceiling by up to 80 per cent is possible in some arenas with the installation of a low emissivity ceiling system. Natural radiation of heat from the ceiling is controlled by placing a highly reflective paint or curtain at the ceiling. The cold surface of the ice no longer “sees” the relatively warm roof but instead “sees” its own reflection, so to speak. If the ice arena is unheated or the arena is operated for six months or less, the effect of a low emissivity ceiling system can be minimal.

Reflective paints can be applied to the underside of the roof deck. The paint is an aluminum based, silver coloured paint. The cost of applying the paint is highly variable depending on the type of surfaces you have, the heights at which painters will be working, and whether local volunteer labour is being used. You will need to determine the life of the paint job, total costs, and the actual savings available.

The foil backing of insulation in metal building construction is a relatively good low emissivity ceiling material.

In such installations only the structural supports would require additional treatment. Even that may prove impractical when the cost/benefit analysis is examined, as discussed in an earlier section.

An alternative is to install low emissivity ceiling curtains suspended on wires, an approach developed for rinks and arenas. Its characteristics, installation costs, and performance are documented.

Ceiling curtains also improve illumination and reduce ceiling condensation.

## Section summary

This section looked at several ways of saving energy in rinks and arenas. Your budget and your expenses will dictate what you can or cannot afford. Categorize the saving measures by initial cost according to operating cost, low cost, and high cost measures.

Note that energy savings are not additive but are multiples of each other. For example, a measure that yields 15 per cent savings combined with a measure that yields 10 per cent savings does not produce 25 per cent savings, but 23.5 per cent savings ( $0.85 \times 0.90 = 0.765$  or 23.5 per cent of the original).

In short, certain low cost energy efficiency measures produce big savings that pay back quickly. Subsequent high cost energy efficiency measures usually apply to a system that has lower operating costs, making it harder to realise big payoffs. The KISS principle tends to pay off best. Keep it simple and straight-forward.

### Operational measures

- Keep the ice thin, ideally 1 in. (25 mm) thick.
- Set back spectator area heating when unoccupied.
- Dump snow outside of the building.
- Allow ice temperatures to rise overnight, 28 F (-2 C) maximum.
- Match lighting levels to facility use.
- Paint ice with reflective, thermally conductive paints.
- Maintain brine at a specific gravity of between 1.20 to 1.22.
- Review your ventilation practices.
- Clean the rink floor slab thoroughly before installing ice.

### Low cost measures

- Caulk and weather strip the building shell.
- Perform basic maintenance on all systems.
- Install timers on ventilation equipment.
- Install timers on lighting.
- Install locking thermostat covers to prevent tampering.
- Install low flow shower heads to reduce domestic hot water consumption.
- Modify ventilation equipment to minimize waste and maximize savings.
- Insulate hot and cold water piping, especially in cold areas.
- Alternate water supply.

### High cost measures

Install the following:

- brine pump cycling or 2-speed pumping systems;
- variable brine temperature controller;
- variable speed pump controller;
- dehumidification system;
- computerized total management systems;
- flood water heat recovery equipment;
- domestic hot water heat recovery equipment;
- heating system heat recovery equipment;
- power factor correction capacitors;
- high efficiency motors;
- demand limiting systems;
- low emissivity ceiling system (if you heat your rink for a long season);
- reverse osmosis flood water purification system.

# 7. Lighting

Good quality and effective lighting systems are necessary to create a pleasant functional indoor environment. This section outlines some of the design concepts for achieving the most effective use of electrical energy in rinks and arenas.

Lighting must be considered as a system: an efficient lamp must also be used with an efficient fixture. It is also important that the fixture perform effectively for the intended environment. Lighting must be reasonably uniform for specific applications, with low glare properties. Good colour rendering may be necessary, so lamp selection is critical.

Lamp output is measured in lumens. For example, a 60-watt incandescent lamp bulb delivers about 800 lumens of light. For efficiency comparison, lighting system efficiencies, in terms of lumens per input wattage (including ballast losses) are outlined in the following table. In general, as lamps wattage increases, so does lamp and system efficiency.

Please note, however, that reducing lighting energy consumption in locations where heat from the lighting helps warm an area will increase your annual heating costs.

## Lighting sources for indoor recreational facilities

Source	Lamp wattage (Nominal)	System wattage	Lamp lumens	Lamp life (hours)	System efficiency (lumens/watt)
Incandescent	200	300	3,500	1,000	17.5
Incandescent	300	300	6,000	1,000	20
Incandescent	500	500	9,900	1,000	20
T8 fluorescent (4ft)	32	62	2,800	15,000	90
T8 fluorescent (8ft)	59	115	5,800	15,000	90
Compact fluorescent	13	15	800	10,000	50
Compact fluorescent	26	30	1,800	10,000	60
Metal halide (standard)	175	220	13,000	7,000	60
Metal halide (standard)	250	300	20,000	10,000	65
Metal halide (standard)	400	470	36,000	15,000-20,000	75
Metal halide (pulse start)	175	210	17,000	15,000	80
Metal halide (pulse start)	250	295	25,000	15,000	84
Metal halide (pulse start)	320	370	35,000	20,000	95
Metal halide (pulse start)	400	455	44,000	20,000	95
Light emitting diode (LED)	Refer to the Commercial Lighting Program's web page at <a href="http://hydro.mb.ca/your_business/lighting">hydro.mb.ca/your_business/lighting</a> for technical information.				

Notes:

- **Fluorescent systems** are based on electronic instant-start two-lamp ballasts suitable for cool environments (-10 C to -18 C).
- **Compact fluorescent systems** are based on single lamp magnetic ballasts, which are most popular. For electronic ballasts, system wattage can be reduced by about 10 per cent.
- **Metal halide lamp** life is based on 10 hours/start.
- **New pulse start metal halide systems** are about 20 per cent more efficient than the older, probe start or standard metal halide systems.
- Although listed for comparison purposes, incandescent lamps are not generally recommended and should be used in non-critical areas where lights are normally frequently switched (i.e. bathrooms, storage rooms, etc.).

## Common sources

Sources common in recreational facilities are as follows:

**T12 fluorescent.** High output (HO) lamps (mainly 8 ft.) are popular because of good low-temperature performance. Low temperature lamps are available for both HO and slimline tubes.

Standard 8-ft. slimline and 4-ft. standard lamps are also used sometimes with heat-retention jackets. Switching to T8 fluorescent is recommended, but allowance must be made for light output reduction at “cool” temperatures. The use of suitable lamp jackets is very effective. It may be more practical to simply use totally enclosed fixtures, which provide much better protection for lamps.

Under the fairly recent Energy Efficiency Act, only low wattage versions of the T-12 lamp are readily available. For example only the 34-watt version of the 4-ft. lamp is available to replace the old and very popular 40-watt lamp. High colour rendering index (CRI) 40-watt lamps are available but may be more expensive. Similarly, there are 60 and 90 watt (HO) 8-ft. lamps to replace the old 75-watt slimline and 105-watt HO lamps. Traditionally these low wattage versions are harder to start at cooler temperatures and therefore do not perform as well as their full wattage counterparts.

Conversion to T8 lamps is recommended. T8 lamps are typically 15–20 per cent more efficient than T-12s, with better colour rendition.

**Mercury vapour (MV).** This old lamp type is very reliable, with long lamp life. Efficiency is low, typically lower than T-12 fluorescents. Metal halide lamps are 40–50 per cent more efficient than MV.

## Lighting levels

Lighting levels are typically measured in either foot-candles (FC) or lux (L). By definition, a foot-candle is the intensity of one lumen falling on one square foot of surface. The metric lux is one lumen falling on one square metre, with the conversion factor:

$$1 \text{ FC} = 10.76 \text{ lux}$$

Light levels are normally measured on a horizontal plane, 2.5–3 ft. above floor level or right at ice surfaces. A light meter (photometer), which is used for this measurement, responds only to the visual component of the energy radiated by the lamp/fixture combination.

## Typical lighting levels

Location	Foot-candles
Auditorium, public spaces	10–20
Bathrooms	10–20
Curling (tournament)	
Tees	50
Rink	30
Curling (recreation)	
Tees	20
Rink	10
Hockey (professional, television)	150
Hockey (professional, college)	100
Hockey (amateur)	50
Hockey (recreational)	25–30
Offices	50–75
Cafeteria	5–10
Kitchens	50–100
Meeting rooms, administrative	30–50
Stairs	10
Main entry (exterior)	5
Parking lot	1–2

Since lighting can easily account for about one-third of the total energy, it is important that all systems be efficient. For example, lighting of ice surfaces can be accomplished using efficient wide beam fixtures, but it is very important that wall reflections as well as ceiling reflectance be fairly high – at least 50 per cent.

Light will diffuse well with good uniformity over the target area. The loss of one lamp should not result in a harsh dark spot. Harsh shadows should not result from the players/participants.

A typical hockey rink of 15,000–16,000 square feet can be easily lit to 25–30 FC at a power density of one watt per square foot using metal halide sources, with good grade fixtures. Reflectance should be relatively large, for low glare and efficiency. For safety, use totally enclosed fixtures.

## Lighting options (hockey rink 85' x 155')

Option	Metal halide std/pulse	High pressure sodium
Minimum mounting height	20 ft. 0 in. (6.1 m)	20 ft. 0 in. (6.1 m)
No. of 400 watt lamps required for a skating rink	32	24
Light level above rinks in foot candles (and lux)	28 (301)	26 (280)
Lumens per watt	75	110
Lamp life (hours)	18,000	24,000
Light loss over life of lamp	25%	10%
Warm-up time (minutes)	3-5	3-4
Re-start time (minutes)	8-15	0-1
Colour of light	clear white	golden
Consumption of power by above in kilowatts	11	9.6
Power distribution	0.96W/sq. ft.	0.72W/sq. ft.
Hours per month	480	480
Cost/month at 2.12c/kWh on (runoff rate) hours/month	\$111.94	\$97.69
Cost/month at \$8.41/kVA on installed kW	\$92.51	\$80.74
Total cost per month	\$204.45	\$178.43

## Lighting systems

### Incandescent

Because of its relatively poor efficiency, this source is quickly being displaced by other lighting sources. It is still used in areas where lights are to be switched often, dimmed for variable output, or in very cold temperature applications.

Life is generally about 1,000 hours, with extended service versions of about 2,500 hours. Another category called long life can reach operating hours of 5,000–6,000 hours.

Colour rendition is very good. A close “relative” of this source is quartz, which is basically an incandescent filament in an envelope containing special gases. Efficiencies of about 21-23 lumens per watt with life ratings of 2,000 hours can be achieved.

Loss of lumen output at the end of life is normally less than 10 per cent of the initial values. Loss of lumen output in cold weather is less than 5 per cent.



Above: Open style fluorescent fixture. Left: The T8, top, measures 1 inch in diameter; the T12 below it, 1.5 inches.

### T8 fluorescent

This source is extremely popular because of its efficiency, relatively good colour rendition, and very good life (15,000 - 24,000 hours).

The lamp requires a ballast for operation because it is an arc discharge lamp. Standard ballasts are designed for reliable operation down to (50 F) 10 C, with low temperature versions available down to (0 F) -18 C. Depending on actual fixture construction, fluorescent lighting still remains a very economical lighting source. Sometimes lamp jackets or sleeves are used over the lamps to maximize light output at cool temperatures.



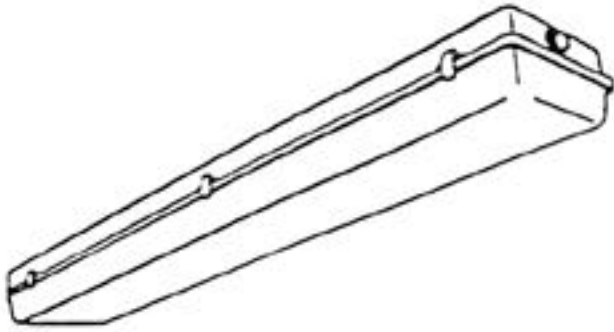

*This enclosed fixture is dust and moisture-tight and made of non-corrosive materials for long life in rinks and arenas.*

There is no problem with fluorescent lights during momentary power dips (such as during the starting of large motors) as arc re-strike is virtually instantaneous.

Lamp output is highly dependent on temperature. Output is maximum (100 per cent) at about 77 F (25 C) and falls to about 70 per cent at 30 F (-1 C). Loss of lumen output at end of life is normally about 20 per cent of the initial values.

### **Metal halide (standard technology or probe-start)**

This source is effectively the same lamp type as mercury vapour except that metallic additives have been added for extra efficiencies. It requires a somewhat different ballast from a mercury lamp because of higher starting voltages.

A mercury lamp operates well on a metal halide ballast, but a metal halide lamp does not operate on a mercury ballast.

Warm-up and re-strike times for metal halide lamps are slightly less than mercury. Because of its good efficiency as well as very good colour rendition, metal halide is a very popular source.

A lumen loss of about 30 per cent can be expected at the end of life. Some metal halide lamps have tended to explode at the end of their life, particularly if they were used continuously and never shut off. Rated life is about 10,000 to 20,000 hours. There is very little lumen loss at lower temperatures [30 F (-1 C)] compared to fluorescent lamps.

Metal halide lamps perform best in the base-up or base-down operating position. There is a roughly 15 per cent light loss in the horizontal (up to plus or minus 30 degrees) position. Always select a fixture with base-up burning for efficiency and ease of maintenance.



*Enclosed pulse-start metal halide lighting fixture.*

For ice rink applications, always specify -30 C operation, as ballasts with slightly higher open circuit voltage can be provided for starting reliability.

### **Metal halide (pulse-start)**

The new technology of pulse-start metal halide should be considered primarily due to increased lamp efficiency of about 20 per cent over standard metal halide.

In some cases lamp life is also longer.

Pulse start is now available in a broader range of wattages between 175 and 400 watts. This lamp type uses a starter to ignite the lamp, rather than relying on the ballast open circuit voltage. As a result pulse start has better cold temperature starting reliabilities than the standard (probe-start) MH lamps.

Due to the high activity of pulse start systems, both fixture and lamp pricing is being reduced. As a good rule, the total fixture (and lamp) cost of a standard versus a pulse-start metal halide system is about equal, even though about 20 per cent fewer pulse-start fixtures are required. There is less installation cost and more important, less energy is required for the future life of the system.

Warm-up and restart-time is faster for pulse-start technology.

### **CAUTION**

For all MH lamp types, it is very important that failed lamps be changed out quickly to avoid progressive damage to the ballast.



*High pressure sodium outdoor wallpack fixture*

## High pressure sodium (HPS)

This source is quickly gaining popularity in both indoor and outdoor applications because of its efficiency, low cost, and excellent lumen maintenance.

A loss of about 20 per cent of initial output can be expected at the end of its life. The colour of light is golden or light amber and is quickly gaining acceptance in all applications where colour rendition is not critical.

A good variety of lamp wattages is available (70, 100, 150, 250, 400, and 1,000 watt) as well as fixture types by many manufacturers. Ballasting for HPS sources is more critical than for mercury/metal halide sources as the ballast must have greater regulating properties as well as an electronic starting circuit to “fire” or start the lamp. Ballasts must be integrally mounted with the lamp because of the high lamp ignition voltages required.

Because HPS lamp output is relatively position insensitive, lamps can be operated in any position. HPS has excellent cold temperature operation and quicker warm-up as well as restrike times, compared with mercury and metal halide.

HPS does not exhibit arc tube rupturing at end of life. A totally enclosed fixture is still recommended, particularly for hockey rinks.

Although lamp life is normally 24,000 hours, a dual-arc HPS is also available, with the advantage of instantaneous restrike during a power “dip” or very short term outage as the “second” arc restrikes immediately while the “first” arc cools down. As a result lamp life over these twin arcs is in the range of 30,000–40,000 hours.

As with metal halide a burned-out lamp should be changed quickly as the ballast will gradually suffer damage.

It is very advantageous (if possible) to match exterior as well as interior lamp wattages. A very popular lamp is the 250 watt, as well as the 400 watt.

## Low cost/no cost solutions

1. Clean lenses and reflectors of light fixtures.
2. Consider lower power lamps when relamping. Full power, 32W 4-ft. T8 fluorescent lamps are available in energy efficient (EE) versions of 30W, 28W and 25W. No ballast change is required. Check with your lighting supplier for the latest version of the lamp available and ballast compatibility.
3. Consider LED lamps instead of metal halide or HPS when relamping. There is a series of LED lamps which will work with HID ballasts. Replace existing glass lamps with LED. Check with your lighting supplier for the latest version of the lamp available and ballast compatibility.
4. Check the temperature of the lamps and the fixture. If you’re using a small, vapour-tight fluorescent fixture with full power T8 lamps, the temperature of the lamp may be higher than the optimal 25 C for light generation.
5. Consider replacement with smaller power EE lamps, which would the lower amount of heat in the fixture. This would lead to lower temperature of the lamp (higher efficiency of the light generation) and ballast (longer life of the components).

## Operational measures

1. Turn off lights when not in use, but be careful with frequent switching of fluorescent lamps. Less than 30 min./start may shorten the life of the lamp and increase maintenance cost.
2. Pay attention to interactive effect. Part of the heat generated by light will need to be replaced by heating system.

## High cost solution

1. Replace the lighting fixture with new LED technology.
2. Rewire fixtures to be on separate circuits so multilevel switching can be implemented.
3. Install automated control system to turn off lights when not needed.

## Lighting ballasts

The average rated life of ballasts for most ballasted light sources is 15 years, and up to 20 years for premium quality ballasts. The life of a ballast can be dramatically shortened if it is subjected to high temperatures for extended periods. For HID ballasts, it is advisable to leave a minimum 6-in. space between the top of the ballast housing and the ceiling.

Fluorescent fixtures should always be tightly surface mounted to ceilings to improve heat transfer. Suspending fixtures from ceilings results in low ballast temperatures. However, T8 electronic ballasts have very low losses and are not as temperature critical as the magnetic versions.

## Lighting application

### Converting your fixtures

Converting old incandescent fixtures to either MH or HPS is not recommended because the insulation on socket wiring at the fixture is very likely brittle and poor. Other reasons include the following:

- HPS requires a new pulse rated socket.
- Adapting the incandescent reflector to ballast housing can be difficult.
- Positioning the new lamp in an incandescent reflector requires extensive trial and error.
- The overall conversion requires the scrutiny of approving authorities before use.

In contrast, converting T-12 fluorescent fixtures to T-8 technology is much easier. In the case of bi-pin lamp sockets, only a ballast and lamp change are required.

Simple open-lamp fluorescent fixtures should not be used in the rink area without a solid (non-slotted) reflector. This type of reflector greatly increases performance and forms a thermal cavity for the fluorescent lamp, to increase lamp ambient temperature over ice surfaces. The reflector also protects the lamps from overhead moisture dripping.

There is still the additional option of adding sleeves or jackets on fluorescent lamps for temperatures well below freezing (-10 C to -18 C). Keep temperature stratification in mind. If the ice surface is kept at about -5 C, the temperature about 15 ft. above surface at the fixture could sit at the freezing point.

For curling rinks, use either reflected units or “wrap-around” (lens) fluorescent units. For hockey rinks, MH and HPS (or a combination) is more practical because polycarbonate lensed fixtures can be used, with the additional option of wire guards. The addition of wire guards is a significant add-on for fluorescents because of the relatively large fixture area.

Low wattage incandescents (40, 60, and 100 watt) can be converted to compact fluorescents using new surface mounted fixtures or possibly the recessed type. Where possible it is more economical to use the linear 4-ft. lamp (T8) even if a single lamp fixture must be used. A single lamp 4-ft, T8 unit can easily displace a 100-watt incandescent lamp.

Converting from incandescent to high intensity discharge (HID) sources should utilize a fixture with metal reflectors, which are integrally ballasted for economic reasons. The economics of 250 watt and 400 watt versions should be considered. Using an efficient low bay style fixture, it is possible to displace 400-watt mercury with 250-watt standard MH with a very small reduction in light. But pulse start 250-watt MH would easily match a 400-watt mercury vapour. Depending on fixture type, 400-watt MH (standard or pulse) is a very economical option. Colour rendering properties of MH are very good.

The use of high-pressure sodium should be given serious consideration because of the strong market trend to this source. However, it is very important that an entire area, either curling and/or arena, be converted to this source, otherwise there may be a very strong colour contrast with the remaining sources, which may result in a public objection to high pressure sodium. Depending on the details, it may be possible to mix in some metal halide or possibly fluorescents.

Historically, many curling rinks and arenas were designed with a majority of mercury lighting fixtures. Some incandescent lighting was mixed in to provide “critical” lighting in the event of momentary power “dips” which would cause mercury lighting to extinguish for about 15-20 minutes. The removal of such incandescent lighting (if not used for normal lighting), and the installation of emergency battery packs, would yield substantial savings. The additional feature of having emergency lighting in the event of a short power outage is a very important benefit, particularly in skating or hockey arenas.

Where lighting is being converted to another source, it is very important to avoid a significant reduction in the number of lighting fixtures. Fixture glare and lighting system uniformity must be carefully considered. In general, lamp efficiency increases with lamp wattage, but there are some very practical limits. For metal halide, the limit is about 400 watts; 1,000 watt MH should be used at about 24-ft. mounting heights. However, attempting to achieve about 30 FC with 1,000-watt MH will result in very wide fixture spacings, and therefore harsh shadows, particularly if one lamp is out.

## Daylighting

If used properly, daylight can provide the bulk of the illumination required. Desks or work areas should be situated such that light comes from the side. This minimizes glare, veils reflections on the task, and eliminates the problem of people working in their own shadow. The benefits of natural daylight should be balanced against security concerns and the cost of cooling heat generated by the sunlight.

The problem of visibility in arena lighting is complex. The playing surface must be well lit for the players, spectators, and television cameras (if applicable). The problem is that these three functions conflict with one another.

Overhead lighting provides good illumination for the players but it is a harsh light and obscures facial and body detail for spectators and television cameras. Low angle lighting improves spectator viewing but can produce shadows and glare for the players. Limited ceiling height can add extra problems or limitations.

To avoid problems with lighting and glare we suggest that you ask a professional lighting designer to review your ideas and make recommendations. Lighting consultants, electrical contractors, and lighting suppliers can help.

Painting the ice a reflective white helps to diffuse lighting on the playing surface and increase the lighting effect in the arena. Painting of walls and ceilings is equally important.

## Energy efficiency

There are two basics for energy efficiency in lighting: increase efficiency where possible, and if you don't need it shut it off.

### Lighting efficiency

As discussed above, increasing the efficiency of your lamps means replacing an inefficient source like incandescent with a more efficient source such as high-pressure sodium or fluorescent (depending on the application).

The same rule applies to the selection of efficient fixtures as well. It is pointless to put an efficient lamp in an inefficient fixture or poorly selected fixture. Also remember that the efficiency of a lamp increases with power rating of the lamp.

## Lighting control

Uncontrolled lighting wastes energy and money. The first step in controlling lighting is manual switching by someone responsible for turning lights on or off as required by the schedule for the facility. In typical public facilities a schedule of events is established, and areas to be used are defined.

Be careful not to switch lights off too frequently, otherwise you might reduce lamp life significantly. A good rule for fluorescent lights at room temperature is to turn the light out if the room will be unoccupied for more than 15 minutes. For MH, HPS and fluorescents over ice surfaces, consult with manufacturers.

For example, during figure skating practice only one dressing room will be used and the arena lighting levels can be lower than for hockey. There may be a few spectators but the kitchen areas won't likely be needed. So you can keep lighting levels low in most areas and off in the unused change rooms and kitchen.

Night lights should be used at stairs, washrooms, and other key locations to allow for circulation and security.

The use of time clocks to switch lighting is a very economical way to provide control and conserve energy.

It is difficult to reduce lighting levels without major renovations, including rewiring or adding special equipment to existing facilities. Evaluate your options when new construction or replacement is under consideration.

## Planning an automatic lighting control system

Automatic lighting systems must be planned according to area or work performed, time of day, time of week, lighting level requirements, availability of daylighting, manual override needs, and safety.

Automatic lighting control should be considered for all fluorescent and high intensity discharge lighting installations. Electrical engineering consultants and lighting designers will be able to help you in the selection and application of automatic lighting control.

Three lighting levels can be designated for different ice surface uses. The lowest level of light is used for figure skating, the next for ice cleaning, and the highest level for hockey. A variable manual setting can also be used to control the light levels between the lower and highest settings. The control unit is wall mounted and is simple to operate.

A photocell sensor is located in the middle of the ceiling. It keeps light levels constant in each setting, compensating for lamp aging, lens and dirt depreciation, and natural daylight. The system requires dimming ballasts.

Additional savings are possible by supplementing an automatic energy control system with timing controls to dim lighting during low-use periods.

About 30 per cent of the arena's electrical consumption for lighting has been saved by using this dimmer system. Savings of this amount could be expected in most lighting applications. The payback on the system, however, depends on the size of the lighting load and operating hours. It would range from five to 10 years.

The other significant factor to consider in reducing lighting levels is that the ice surface absorbs a portion of the energy transmitted in the form of light and heat from lamps and ballasts. Eventually, all the energy supplied to the lights must be removed by the ice plant. A reduction in energy provided for lighting therefore creates a similar reduction in the run time of your ice-making equipment, nearly doubling the effective savings by reducing lighting levels.

Refer also to the following section and the section on refrigeration for a discussion of the effects of lighting levels on refrigeration systems, energy consumption, and efficiency.

Another interesting opportunity available to rink owner and operators is to install reflective material on the ceiling. Light from the ceiling fixtures is first reflected off the white ice surface, then off the reflective ceiling. It continues to bounce around until it is eventually absorbed. This re-use of light can greatly reduce the number of light fixtures required, or reduce the wattage required to provide adequate lighting levels in the rink.

As well as lighting benefits, some low emissivity ceilings can significantly reduce refrigeration energy, eliminate ceiling condensation, and improve arena acoustics.

The use of light coloured paint inside the arena, especially on wood surfaces, provides a similar result. A coat of white enamel paint will provide a highly reflective surface for lighting and can act as a vapour retarder. This may be a more economical solution in some instances.

The foil backing on fibreglass roof insulation is similar in effect to a low emissivity ceiling. It also reflects a high percentage of the light to provide a higher lighting level in prefabricated metal structures. Care must be taken to protect the exposed foilback insulation from pucks that could puncture it. Overlooked, it usually leads to severe moisture issues.

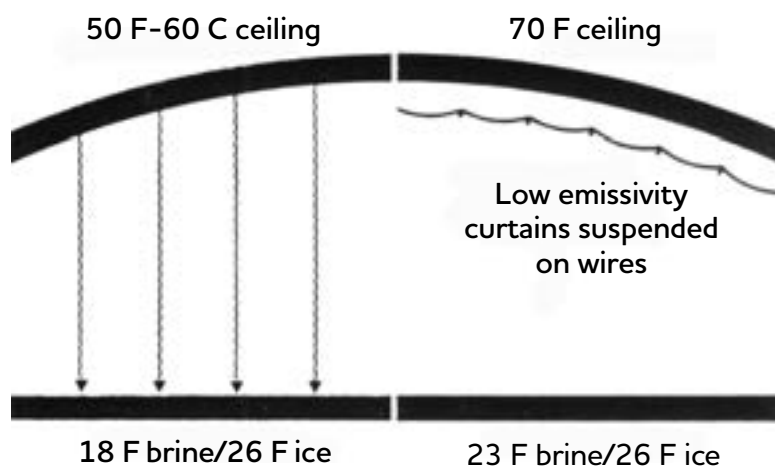

*Reflective ceilings can reduce the number of light fixtures and wattage required, glare, refrigeration energy and ceiling condensation, while improving arena acoustics.*

# 8. Heating effects of electrical equipment

Electrical equipment and appliances, from lighting systems and office equipment to motors and water heaters, produce the useful services they are designed to produce. But the electrical energy they use also appears as heat within the building which can either be useful or detrimental to the building's heating, ventilating and air conditioning systems, depending on the season.

In cold weather, heat produced by the electrical equipment can help reduce the load on the building's heating system. In contrast, during warm weather, heat produced by electrical appliances adds to the building's air conditioning load.

Energy efficient equipment and appliances consume less energy to produce the same useful work, but they also produce less heat. As a result, efficient equipment increases the load on your heating systems in winter and reduces the load on your air conditioning systems in summer.

The impacts of energy efficient electrical equipment and appliances on the energy use for building heating and air conditioning systems are commonly called "interactive effects" or "cross effects."

When considering the overall net savings of an energy efficient product it is very important to consider the interactive effects of the product on building heating, cooling and refrigeration systems. Weighing the interactive effects will result in better informed decisions and realistic expectations of savings.

The percentage of heat that is useful in your specific building or room will depend on several factors including:

- the location of light fixtures;
- the locations of heaters and their thermostats;
- type of ceiling;
- size of the building;
- whether the room is an interior space (no outside walls or ceiling) or an exterior space (perimeter);
- the seasons the building is used;
- type of heating, ventilation and air conditioning system used in each room.

Unfortunately, interactive effects are often quite complex and may require assessment by an experienced mechanical engineer or technologist.



*Changing to energy efficient metal halide lighting fixtures in this curling rink saved electricity to run the lights, reducing the amount of heat generated by the lighting. As a result, the savings gained from installing energy efficient lighting were offset by the additional heating required.*

## Indoor lighting

Energy efficient lighting systems reduce lighting system operating and maintenance costs. In addition, they usually improve lighting quality and increase lighting levels.

But lighting systems also contribute to the space heating requirements of recreational facilities which often operate almost entirely during the long Manitoba heating season.

Electrical energy is transformed initially by a light fixture into light and two types of heating energy, then ultimately all into heat.

For example, 10 kilowatts of T-12 fluorescent fixtures operating for 10 hours will transform 100 kWh of energy into:

- 42 kWh of heat transferred directly from the ballasts and lamps by convection to the air surrounding them.
- 36 kWh of infrared radiant energy which is absorbed by objects within “view” of the light fixtures, to be absorbed as heat which is then transferred to the air by convection.
- 22 kWh of visible lighting energy which is also absorbed by objects within view of the fixture and then transferred to the air by convection.

*Ultimately all 100 kWh of electrical energy consumed by these light fixtures will appear as heat in the building.*

If the same amount of light can be produced by retrofitting the fixtures to T-8 fluorescent fixtures that draw only 8 kW, then in 10 hours of operation the new fixtures will produce only 80 kWh of heat.

If the building is heated, then the heaters may have to produce a large portion of the 20 kWh of lost heat to maintain the same level of heating in the building.

On a winter day, when heating is required, the net energy saving may be near zero.

In this way, the energy you have saved by installing more efficient lighting will be offset by the additional heating required.

The amount of electrical energy that is transformed directly into heat, infrared radiation, and visible light will be different for the various light sources commonly used (incandescent, halogen, high pressure sodium, metal halide, LED, mercury vapour, etc.). However the result is the same: 100 per cent of the electricity used by the lighting system ultimately becomes heat. If you install energy efficient lighting that reduces the amount of heat during the heating season, much of the loss will have to be made up by the heating system in the building.



*In a hockey arena, because the lighting is generally mounted above and away from the heaters and their thermostats, it is difficult to predict how much heat from the lights is useful in space heating.*

If the source of heating energy is less expensive than electricity (typically geothermal heat pump or natural gas, depending on rates and furnace efficiency) the incremental cost difference of the two heat sources will be saved. If it is more expensive (typically oil or propane) the incremental cost difference of the two heat sources will be lost. If it is the same (electricity) you will break even.

When the lighting system operates in the spring and fall and neither heating nor air conditioning is needed, the net energy savings will be the same as the lighting system savings.

When the lighting system operates in summer while air conditioning is required, an additional 33 to 40 per cent for air conditioning savings can be added to the lighting energy savings.

In a hockey arena, most of the light fixtures are usually mounted high over the rink surface, while the heaters and their thermostats are at a lower level over the spectator stands. With this configuration the heat transferred by convection directly off the light fixtures is so high up that it is not of direct use to the area where the heaters are in the stands. However, some of the air heated by the fixtures will mix within the building air and be of some use. The exact portion of heat that will be useful as space heating is difficult if not impossible to predict.

In a curling rink, lighting fixtures are usually mounted in close to the heaters and thermostats with a much lower ceiling height and right in the heated space with the curlers. With this configuration very close to 100 per cent of the lighting heat will be useful. Any loss of this heat will have to be made up by the heating system.

## **Outdoor lighting or indoor lighting in unheated areas**

Lighting outdoors or in unheated indoor areas such as hockey rinks is not affected by interactive heating effects. Net overall savings will be the same as the energy savings calculated for retrofitting to energy efficient lighting.

In unheated rinks where several kilowatts of incandescent lamps have been converted to much more efficient LED fixtures, the switch will yield significant energy and demand savings. However, the loss of “waste heat” from the inefficient incandescent lamps has also resulted in slightly cooler air temperatures in the rinks.

## **Ice plants**

You can take advantage of interactive effects to lower the cost of operating your ice plant.

For example a 20 hp brine pump draws about 15 kW. Some 10 per cent (1.5 kW) comes off the motor as heat in the room that houses it. The remaining 90 per cent (13.5 kW) appears as heat in the circulating brine solution. Reducing the run time of the brine pump saves energy and money in two ways:

- It lowers the cost of operating the brine pump;
- It cuts back on the operation of the ice plant which needs to cool less brine, for 33 to 40 per cent additional savings.



# 9. Operation and maintenance

An arena is no better than the people running it. The key to successful operation of rinks and arenas depends on the skills and commitment of the staff working there. Having a good building and related system helps, having a good building that is easy to maintain is better, but having a good, well-trained, knowledgeable maintenance staff is best.

This section discusses methods and procedures in operating and maintaining facilities that enhance energy efficiency in rinks and arenas with particular emphasis on facilities with artificial ice.

Maintenance is critical to the energy efficiency program in any type of facility or process. This is because maintaining operating efficiencies is often as difficult as it is to increase efficiencies. Maintenance of buildings and equipment is the most important function in energy management.

In new construction it is recommended that operating and maintenance (O & M) manuals be prepared. If you have one for your facility, consider it a bonus. Often these manuals are lost or forgotten. The following material was written with the operator of an old facility in mind, someone who may not have the benefit of an O & M manual at their disposal.

You can compile your own O & M manual by contacting the suppliers and manufacturers of the equipment in your facility and requesting copies of their maintenance procedures. Major Canadian cities will have representatives for most equipment and they are often able to assist you.

## Building envelope

Maintaining the building envelope or building shell is related to the same four systems listed in Section 4: air barrier system, insulation, cladding (for roofs, waterproofing), and a vapour retarder.

If maintenance of these four items is neglected it is possible for the building structure—the studs, columns and beams—to deteriorate.

The first three items are the most important systems to maintain, although it is easy to maintain a vapour retarder. It is particularly important to maintain the air barrier system and the cladding or exterior shell of the building. The air barrier protects the building from moisture and condensation, and the cladding protects the building from rain.

A well maintained building envelope saves energy in two primary ways. It prevents the uncontrolled flow of outside air through the building, and it improves the thermal integrity of the building. This reduces heat losses and lowers heating and refrigeration bills. Excessive humidity in rinks and arenas puts additional loads on the refrigeration equipment, so limiting moisture penetration either directly or as airborne humidity conserves energy.

## Symptoms

Section 4 listed several problems related to moisture accumulation. On masonry buildings, efflorescence is caused by moisture moving through the bricks and carrying with it the dissolved minerals and salts that make up part of the bricks. When the solution reaches the brick surface, the salts and minerals are deposited there as the moisture evaporates. Surface staining by other minerals or materials is similarly caused, when moisture carries these dissolved minerals and particles through to the surface of the building.

Such staining is a sign of other potential problems related to the accumulation of moisture within the building envelope. Cracking of the exterior cladding can occur when normally dry materials, such as brick or stucco, absorb moisture and swell. Spalling of masonry and concrete block is caused primarily by moisture accumulating in the bricks or blocks. It occurs when the saturated materials go through a number of freezing and thawing cycles.

When the moisture freezes it expands, displaces the surrounding material, and gradually leads to a breakdown of the brick or block. This occurs most easily on the surface, since the resistance of the material is weakest there and the surface goes through more freeze and thaw cycles. In severe cases a number of bricks or blocks may disintegrate sufficiently to place the entire structure in jeopardy.

Other problems discussed in Section 4 include corrosion and rusting of metal components, icicles, displacement of materials, and meltwater running out of the building when it warms up. All of these indicate the presence of water in the building envelope, whether as frost, ice or liquid. Maintenance is required to stop the accumulation of the water, although it is important to allow any entrapped water to drain.

## **Air barrier system**

Reseal cracks and joints on the interior of the building every year, during summer or early fall. If a membrane system was used inside the walls and ceiling it may be impossible to seal any leaks detected during operation or airtightness tests. However, sealing of the interior and retesting will eventually transform the interior surface into the air barrier system.

Air leakage should be tested during commissioning of a new building and periodically throughout its life. This provides both engineering and practical knowledge of the amount, location, and type of air leakage.

## **Insulation**

Maintaining the insulation is seldom necessary if other maintenance items are satisfactorily handled. Maintenance is required only if the insulation is displaced, creating a cold spot on the interior, or if the insulation becomes wetted. This is more common in the roof than in the wall, although in locations where the air barrier system or cladding fail, the wall insulation can become wet. Insulation, such as fiberglass batts, will drain most moisture in a vertical installation such as a wall cavity. Most other situations will require that the insulation be replaced with dry material. The cause of wetness must be fixed as well.

## **Cladding – rain penetration**

Caulk unplanned cracks or openings in the exterior cladding with good quality exterior grade caulks. Don't seal planned openings, like weep holes through the wall. Such holes allow the moisture to drain out of the building envelope and you must ensure that this remains possible.

Rain or moisture penetration is caused by four different forces:

- Momentum of the rain drops can drive them past the exterior cladding elements into the assemblies;
- Water draining from the surface of the building may flow by gravity into the assemblies through cracks or openings;
- Water from the wetted surface may be absorbed into the cladding and interior components of the assemblies;
- Air infiltration—air leaking from the exterior to the interior—will carry moisture with it during periods of rain.

Sealing the air barrier system on the inside of the building to stop wind driven rain is necessary to block the wind from coming through the building. If the wind can't come through the wall it won't get into the wall in the first place, bringing rain with it. This is often called the Rainscreen Principle.

It is important to maintain flashings so that water does not drain into the wall or get blown past the flashing.

## **Vapour retarder**

Where polyethylene is used in the interior of the wall and ceiling, little maintenance is required for it to function as a vapour retarder. A vapour retarder can be something as simple as three coats of a good oil-based paint. Maintenance of the vapour retarder should ensure that it is not becoming worn.

The vapour retarder may or may not be installed as part of the air barrier system. If it acts as the air barrier as well as the vapour retarder, it must be maintained as both.

## Heating and ventilation

A well maintained heating and ventilation system is like a well-tuned car. It runs better and quieter, uses less fuel, lasts longer and has a higher resale value when you're ready to trade it in. An investment in maintenance pays dividends in the long term.

Follow the procedures listed below to identify problems so they can be corrected before energy is wasted through inefficient or ineffective equipment.

Making equipment last longer saves money and that's what energy efficiency is really all about.

## Heating equipment

**Gas fired.** Make sure that your heating equipment works at maximum efficiency. Gas fired heating equipment including furnaces, boilers, unit heaters, water heaters, and radiant heaters should be checked monthly and thoroughly inspected yearly.

Your monthly checks should include:

- gas valve;
- thermostatic controls and limits;
- pilot light or electronic ignition;
- flue connection;
- chimney;
- gas piping and valves.

Your annual inspection should include:

- removing and cleaning all burners;
- checking flame and adjusting gas feed and combustion air baffles if necessary;
- replacing any combustion air filters on radiant heating equipment;
- cleaning flue passages on heat exchangers;
- removing the chimney base tee inspection plate;
- performing a water test for boiler water.

**Electric.** All equipment should be inspected monthly and thoroughly checked annually before the heating season starts.

Monthly inspections should include:

- thermostat controls and limits;
- contactors;
- power cables and control wiring.

Annual inspections should involve cleaning and vacuuming heating elements.

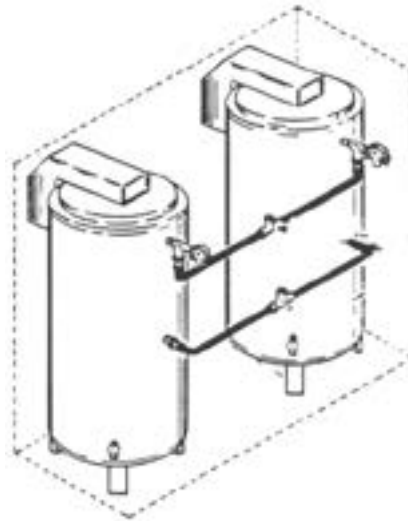

*Domestic water heaters. Make sure you flush and drain their storage tanks once a year.*

*You may be able to avoid the cost of a replacement tank indefinitely by regularly replacing the anode rod in the tank.*

**Water heaters.** Water heaters must be maintained in a manner similar to any other appliance, as noted above. In addition, flush and drain the hot water storage tanks once a year to remove scale deposits. Flush more often in areas with very hard water.

You can extend the life of your water heater, and avoid the cost of a new tank and cleanup, by periodically replacing the anode in the tank.

The anode, a solid rod of magnesium or aluminum, is suspended from the top of the tank. It is there to corrode away, little by little, and in doing so prevent any rusting of the steel water tank.

The average life of a water heater is between nine and thirteen years. In theory, water tanks can last indefinitely if you regularly replace their anodes.

Check your anodes every three to four years, or one or two years if you have very hard, acidic, or softened water.

Anode rods are often about 44 in. long and 3/4 in. in diameter, with a 1-1/16 hex plug at the top. With luck, the hex head will be out in the open.

If you are planning on changing the anode, find out what type of rod your water heater has, what you will replace it with, and where you can get the replacement. Anodes generally cost under \$50 and are available from plumbing supply houses.

**Boiler water systems.** A well maintained hot water heating system saves pump energy by ensuring that pipes and equipment are clean. It also keeps water system piping pressure drops to an absolute minimum.

Boiler water contains a number of inhibitors to control scale, rust, and biological growth. It may also contain antifreeze solutions to prevent freezing of pipes. All these additives need to be monitored to ensure that they are present in sufficient quantities to work the way they are supposed to. The concentrations should be monitored monthly and more often after a significant leak or drain down.

Strainers and filters on water systems should be examined regularly and cleaned out annually. This saves pump energy by reducing pump heads.

All valves should be opened and closed annually to ensure that all parts are lubricated and are operating correctly. If a valve is stuck or doesn't seal tightly, it won't be of any use to you should you need it.

Check expansion tanks monthly to ensure that they are not water logged. Excess pressure will build up in the boiler water if this happens. Check air vents to ensure that they are free of obstructions and do vent any excess air in the system.

## **Ventilation equipment**

The ventilation system can be the greatest waster of energy if it is poorly maintained. Clogged filters waste fan energy. Excess fresh air costs a lot to heat. Slipping fan belts cause unnecessary wear. An out-of-control cooling system makes life uncomfortable.

Properly operated and maintained, the ventilation system provides healthy and comfortable conditions at a very reasonable cost.

In the ventilation and air handling systems, there are four basic components that require maintenance; fans, filters, controls, and cooling.

### **Fans**

Fans and their associated motors should be checked annually and lubricated as directed by the equipment manufacturer. Belts should be checked for wear and deterioration. If belts are questionable they should be replaced rather than risking a break down of the heat distribution or exhaust systems. It is a good idea to keep spare replacement belts on hand.

### **Filters**

Dirty filters waste energy and reduce air flow in buildings. Air filters should be cleaned regularly.

If you have permanent filters they should be cleaned and replaced. Throw-away filters should be replaced with new filters of the same type and style.

The schedule for replacement depends on the type of air that the unit must filter. A heating only unit in a non-smoking area may need replacement once every two or three months. A heavily used lounge with lots of smokers and very little fresh air may require replacement every two or three weeks.

### **Controls**

The controls for ventilation systems are generally very simple (or should be). Room thermostats require little maintenance but should be checked annually to ensure that they are properly calibrated.

Rooftop HVAC units have more complex systems to control ventilation and cooling equipment. Ventilation dampers should be examined annually to ensure that the dampers are moving freely and through the entire range of operation. Check that the mixed air settings are correct.

### **Air conditioners**

Cooling systems should be checked annually by an authorized refrigeration mechanic to help ensure long trouble-free operation.

Most refrigeration mechanics will tell you that 90 per cent of the troubles people have with air-conditioning systems are electrical. If you have any trouble with yours, check the thermostat and the breaker first.

You may save yourself the cost of a service visit.

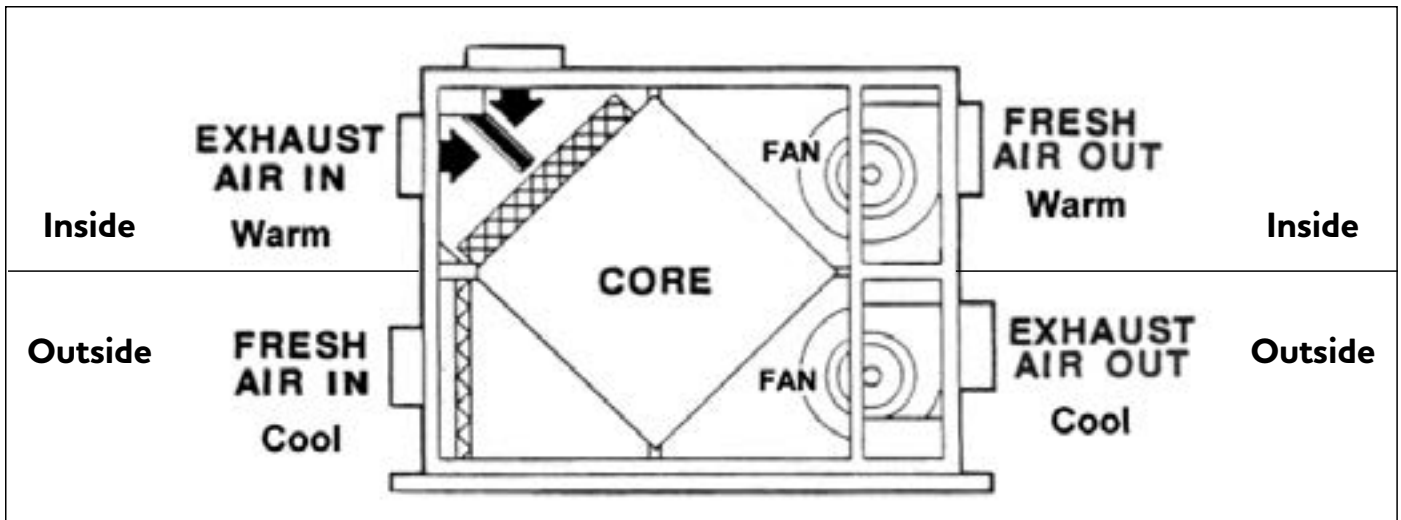

*Air-to-air heat exchanger. Defrosting of the heat recovery core is critical to proper operation.*

## Heat recovery

Air-to-air heat exchangers conserve energy by transferring heat from exhaust air to replacement fresh air.

They consist of fans, ducts, controls and the heat recovery coil. Some units include filters similar to those discussed earlier in this section.

Special care must be taken to ensure that the controls are operating correctly so that the heat recovery core defrosts when required. A coil that does not defrost will plug up solid with ice on the exhaust air side. In that case there will be no exhaust air flow and no fresh air warming.

Care of the heat recovery core differs, depending on the manufacturer and the design. Cores can be constructed of plastic, paper, steel, copper or aluminum. It is best to obtain the manufacturer's recommended maintenance procedures to determine exactly what maintenance is required. Failure to do so may damage the core beyond repair.

## Planned maintenance

Maintain your building and heating systems in the summer when your rink is not too busy and outside work is feasible. Schedule the maintenance in advance and have all replacement belts, filters, etc. on hand before you start. Arrange to have a refrigeration mechanic inspect your air conditioning in April or early May.

If you need to bring in a mechanic from some distance, arrange the work early so that the service agency can schedule other work in your area and reduce your cost by sharing travel costs with other clients.

Schedule monthly inspections so that you don't forget them. Pick a convenient date and be sure that you have any necessary replacement parts or filters.

If this work requires that you spend any time outdoors or on the roof, you won't want to spend any more time than you need to finish your work. Murphy's Law suggests that the day you need to go onto the roof and replace a filter will be the coldest, windiest, most miserable day of the month! Try not to delay too long.

Make a detailed list of the functions that need to be performed for each piece of equipment in your facility. Work with the list and expand it as necessary. The list will help you in your job and will be invaluable for the next facility operator.

## Operation of mechanical systems

The operation of mechanical systems and equipment is ultimately what uses the energy.

The following are energy-saving suggestions on the operation of heating and ventilation systems.

Many of these are also covered, in some detail, in previous sections.

- Shut off exhaust systems during unoccupied times.
- Shut off ventilation systems during unoccupied times.
- Shut off spectator area heaters when there are no spectators (turn them on for games and off during practices or other times of low occupancy).
- Set back heating thermostats during unoccupied times.
- Set cooling thermostats as high as possible during unoccupied hours.
- Install low flow shower heads to save domestic hot water and heating costs.
- Insulate domestic hot water tanks to prevent heat loss.
- Insulate water lines running in unheated areas.
- Provide timed shut-off shower heads to eliminate the possibility of leaving showers running, which wastes water and heat energy.
- Keep room temperatures at a reasonable level. Excessive room temperatures add to heat loss and energy consumption.
- Set back boiler water temperatures in mild weather. Excess heat loss from pipes can cause ventilation rates to increase unnecessarily. Boilers may short cycle and wear out prematurely.

## Ice maintenance

The following section is taken from the Saskatchewan Recreation Facility Association Operators Manual.

There are two main reasons for an ice maintenance program: user satisfaction and reduced operating costs.

### User satisfaction

A well maintained ice surface will be smooth, clearly marked, level and available when required by the users. It will be inherently safe (i.e. free of holes or areas where ice will shear off and free of ridges or bumps that could cause instability while skating).

### Reduced operating costs

Carrying out maintenance tasks, such as edging, on a regular basis reduces the number of times major shavings of the ice will be needed.

Scheduled maintenance eliminates overtime and extra staff needed if the ice is allowed to build up too long.

Reduced ice thickness lowers energy consumption of the refrigeration system and improves ice quality. When water is applied to an artificial ice surface it freezes from the bottom, that is, the heat is removed from the concrete or sand floor. The ice between the water and the floor acts as an insulator. More ice means more insulation; more insulation means it takes longer for water to freeze; the longer it takes for water to freeze the longer the plant has to run; the longer the plant has to run the higher the operating costs.

### FastICE

FastICE is an advanced ice maintenance system that can be retrofitted to an existing ice resurfacer.

The system controls the amount of water used by regulating spray thickness depending on the ground speed of the ice resurfacer. It sprays precise, consistent layers of hot water that produce a safer, faster, and smoother ice surface than a regular resurfacer.

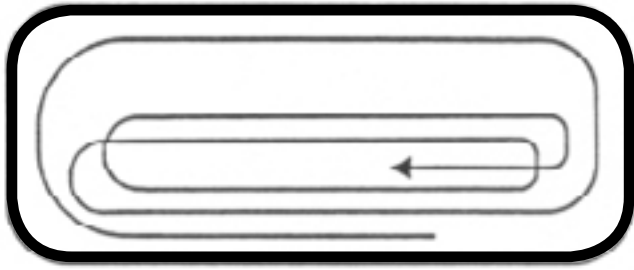

*A common pattern for resurfacing arena ice.*

## Flooding

Most rinks are flooded using self-propelled or pull-type ice resurfacers. Hot water is generally used to give a better bond to the ice and to insure all snow in cuts is melted.

To complete a flooding pattern normally takes 15 minutes. Floods can of course be done faster or slower, but 15 minutes is a good bench mark.

The size of the arena, the type of equipment, and the location where the equipment enters the ice surface influence the flooding pattern. There is no right or wrong pattern to use. See the drawing for a common pattern.

Holes are created in areas where the machine overlaps itself, primarily in goal mouths. Patterns can be varied to help alleviate this.

Flood water amounts vary with activity and length of use. Usually 90 - 100 Imperial gallons (400 - 450 litres) are enough for a normal sized ice surface.

The amount of water used should match activity to avoid ice build up. Depth of cut should be just enough to remove snow. Excess cutting will take out your ice or cut into lines. An average flood builds only 1/100 in. (0.25 mm ) of ice.

### Flooding tips

- Try not to overlap or miss areas when flooding.
- Shut water valve off when overlapping creases, approximately 6 ft. in front of area. Turn water on after passing over crease.
- Drive at a constant speed. If you slow down for the corners, reduce the flow of water onto the ice surface.
- Since most pins, and particularly steel pins, have a tendency to freeze to the ice, it is important to make sure that the pins are a smaller diameter than the holes. It is also important when flooding to keep the water out of the holes.

## Curling rinks

**Pebbling.** Proper equipment is needed – a can, hose, connections and a pebble head. A 3-1/2 Imperial gallon (16-litre) can will give better pressure for the water flow.

Several factors can influence the flow, including the following:

- tube out of can too small;
- hose connections and couplings too small;
- hose too soft;
- air openings in can too small.

Proper pebbling technique is developed only by practice. Never use a wrist motion but use a full arm swing. A wrist motion tends to kink the hose at the end of the inward swing. This cuts down water flow to the pebble head.

When moving the pebble head to the outward swing, the pebble head will be above the centre of the ice surface before it is full of water again. As a result, less pebble is formed on the inward swing side (nearly half a sheet), and uneven pebbles are formed.

To put on an even pebble, keep the head full at all times. Restricted flow creates blobs, as does a clogged pebble head. A quick rinse in a mild acid solution will prevent clogging. Be careful of injury when using acid.

When walking, natural arm and leg movements are simultaneous opposite to each other – right arm forward, left leg back - left arm forward, right leg back. This natural movement has to be taken into consideration when pebbling. It is very hard to take two arm swings while taking one step backward, and when doing so, one is probably moving too slow and putting on too much pebble. In moving backward, use very, very small steps like a backwards shuffle but moving quickly.

When pebbling, keep the pebble head level with the ice during the swinging motion so that the pebble shoots up 18 to 24 in. (450-600 mm) above the level of the pebble head, and the pebble drops down on the ice. When a pebble head is held on an angle to the ice surface, the pebble is shot down on to the ice and on contacting the ice surface, it enlarges and flattens out.

### **The pebble – its size and amount**

The type of play and the temperature of the air and the ice determine the amount of pebble to be used. When starting with a bare ice surface, it is better to put on two fast pebbles than one heavier one. When covering twice, a pebble is set here and there on top of another pebble from the first covering, creating a few higher pebbles and also different sizes. The advantage of this method is that the running surface of the rock has fewer contact points, resulting in keener ice from the first rock thrown.

After a few ends, a different pebble takes over and the rocks still bite. The draw or swing of the ice will not change.

### **Water temperature for pebbling**

The temperature of water used for pebbling depends on air temperature in the rink, ice temperature, quality of rocks, and running surface conditions.

When the air is cold, warmer water is used. In the fall or spring use cooler water. Ideal water temperature is the one that, when the rocks are pushed over the pebble, the pebble does not break off or smash. You should not be able to hear the pebble break.

One method of finding out the correct water temperature is to experiment. During one draw, and using the same size of pebble, vary the water temperature as follows:

sheet #1 with tap water temperature

sheet #2 with 10 F (5 C) warmer water

sheet #3 with another 10 F (5 C) warmer water

sheet #4 with another 10 F (5 C) warmer water

Check the size of the pebble on each sheet, then watch during the game for speed, draw, etc. After the game, check for wear over the playing area, especially in the sliding and hack area.

Take notes on each sheet and compare results. Keeping notes of the temperature of inside sheets of ice and pebble water temperature will provide good references for future use. If the pebble water is too cold, it will freeze too fast, trapping the air in the ice and creating a hollow pebble that breaks off. If the water is too warm, it will partially melt into the ice and flatten out, resulting in a bigger, lower pebble.

### **Maintaining the ice**

The first step in keeping ice clean is establishing and maintaining a member education program. Clean ice gives better playing conditions.

It follows that smoking should not be allowed on the ice. Carpet on walkways keeps debris off the playing surface. (Astroturf is not recommended because the material is too hard and damages the running surface of the rocks.) Carpet should be cleaned properly and regularly. The areas behind hacks and under the rocks should be swept after each game. An extra small piece of carpet behind each hack can be used not only by the players to wipe their feet before delivery, but also to clean debris from the running surface of the rock when maintaining the ice.

A sheepskin or 8-ft. mop should be used over the entire ice surface between games. If you pebble without cleaning, all the dirt, straw, cornpulp, small sweater particles, etc., will be in the ice.

A regular maintenance program is needed, depending on the hours of ice time which are used. Scraping or burning should be done at least once a week and more often if needed. The cleaning of the ice and the sidewalks after every game is essential.

Hacks should be washed out after every game and dried (a small propane torch is a handy tool for work around hacks). Make sure that there is no pebble in the rubber hack. Clean under the rocks after every game. Use a hand scraper on the ice under the rocks and behind the hacks. The area around and behind hacks can also be cleaned by washing with hot water and a mop. Repair chipped hack areas with slush; let it freeze and scrape smooth.

When levelling by flooding during the season, make sure the ice surface is clean. Never attempt to flood if the air temperature is below 32 F (0 C). The water will freeze from below and also from above, trapping the air from the water and creating shell ice.



## Ice edgers

There are two basic types of ice edgers: gasoline powered and electric powered. They are generally used to shave the edges of a sheet of ice. They may also be used to cut in lines and rink markings.

Gas powered edgers are superior to the electric ones because they are generally lighter, easier to handle, more flexible, and not restricted by the length of the power cord. They usually cover a smaller area than the electric edgers. However, their flexibility and speed more than compensate for this.

## Uses

It is hard to imagine not having a power ice edger, and still maintain a good ice surface. Edging the rink daily will, in a lot of situations, reduce the number of major shavings required. Further, it assists in keeping the edges smooth and square. The edger should be part of the daily ice maintenance schedule and may be used at other times of the day as time permits.

## Operating tips

Keep all guards in place.

Put safety first. Be properly outfitted, never attempt to make adjustments near the cutting blade when it is operating, and never walk backwards when operating the machine.

Cut the ice 1/16 to 1/8 in. (1.5 to 3 mm) at one time. Do not overwork the machine. Do not push on it. A normal walking pace is all that is required.

Make sure the cutting blades are securely in place. Follow the manufacturer's guide for maintenance, service, and care. Check the oil level before each operation. Check the fuel level. Check the spark plug connection and replace the spark plug at least yearly. Check blades for sharpness weekly. Once the cutting edge is nicked or slightly rounded, replace the blade with a sharp one. These carbide tipped blades are sharpenable by some saw service companies.

## Problem areas and solutions

### Goal creases and other wear areas

Goal creases receive the greatest amount of use during a game, resulting in a thinner ice cover.

To compensate, raise the resurfacer blade slightly when passing over the creases. Further, at the end of the night's use, distribute extra water in the crease area. A five gallon plastic pail full of water each night will help keep the creases built up. Water may also be added during the day when there are no activities on the ice for one to two hours.

Corners and face-off circles can become severely rutted from public skating. Fill ruts with slush in the same manner as cracks are filled. These areas should be repaired immediately following public skating.

Wear areas may also be caused by extensive hockey practices, stops and starts, or laps. These areas may be repaired using slush. Coaches should be encouraged to move the location of skating drills around on the ice surface to allow for more even wear.

### Corners

The corners of an ice sheet have a tendency to build up quickly for several reasons. If allowed to go unchecked a noticeable rise will develop.

Corners where the ice is 2-3 in. (50-75 mm) and even up to 6 in. (150 mm) thick are not uncommon. This results in lines that cannot be seen, pucks that slow down or take unusual hops, and the delayed freezing of flood water.

The reasons for corner build-ups are improper operating procedures. As mentioned earlier, it is important to drive at a constant speed and reduce the water flow through corners. The operator of the resurfacer is in control of how much and how fast ice builds up in the corners.

The other reason ice builds up in the corners is because most skating takes place away from corners.

If the area is used less, then not as much ice is scraped off by skates. To reduce the problem incorporate all of the following activities into your maintenance program:

- sweep the corners before flooding;
- edge the corners daily;
- drive at a constant speed;
- reduce water flow (during games) or shut it off completely (during practices) when going through corners;
- shave corner areas daily.

### Boards (edges)

The ice along the sideboards also builds up from increased water and lack of skate traffic. Again, by following some easy practices, the need for major work can be reduced.

Drive at a constant speed or reduce water flow along the boards. A couple of times each night take off 1/16 - 1/8 in. (1.5-3.0 mm). This will keep the edges square and reduce build-ups. Sweep the edges before flooding.

### Cracks/chips

Cracks usually develop because the ice is too hard. Most cracking can be eliminated by keeping the ice at 18 to 20 F (-7 to -6 C).

Cracks may be repaired by filling them with water or slush. Apply only a small amount at a time and allow it to freeze completely before applying more water or slush.

Chips are usually caused by the front picks of figure skates. To reduce such chips one option is to raise the ice temperature to 24 F (-4 C). Chips can be filled with slush and packed.

### Repairing shell ice

Shell ice develops when you apply too much water in an area at one time and the water freezes in sections, creating a void between two layers of ice. The trapped air acts as an insulator and prevents good heat transfer through the ice.

Using the chipper, remove all shell ice and reflood (pebble) the area slowly in stages until the ice is built up level again.

*Typical areas of uneven ice.*

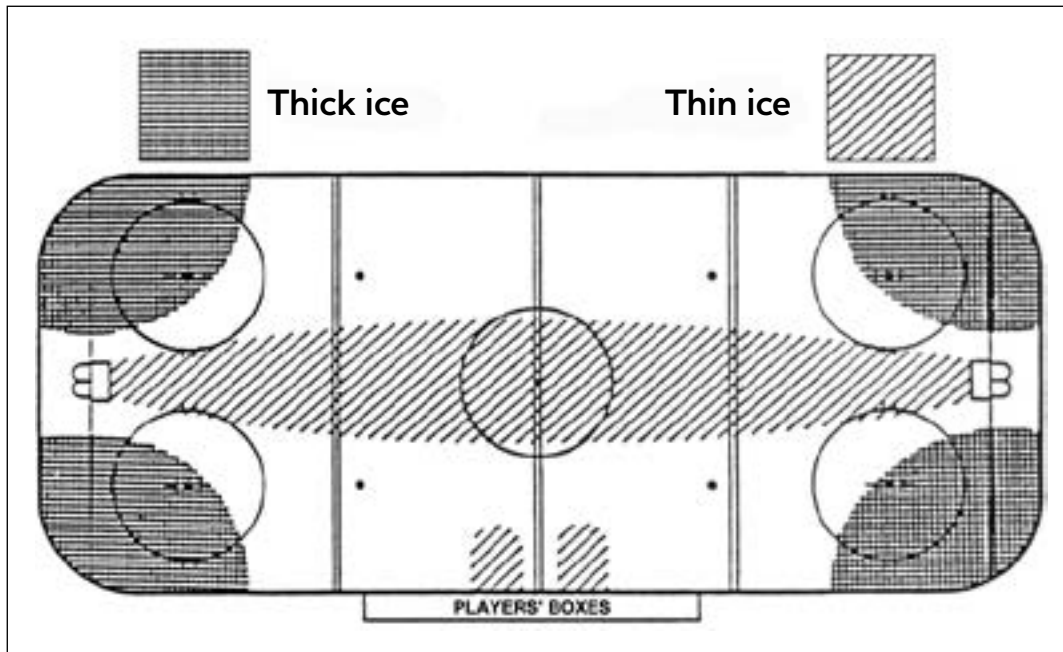

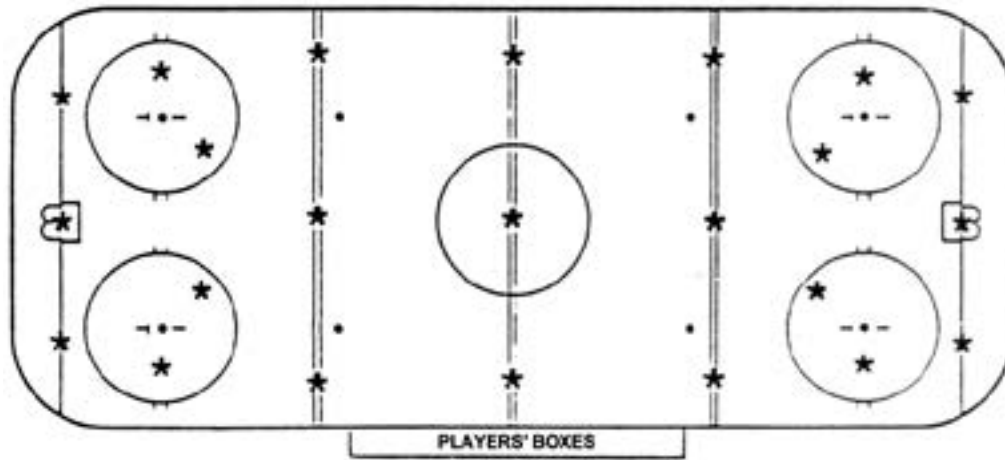

Check ice thickness at the points shown.

### Ice shaving

If there are excessive build-ups of ice, daily maintenance will not eliminate the problem altogether, although it will reduce the number of times a year major shavings will need to be done.

Use a major shaving to reduce the ice level over the entire rink or just specific areas. A major shaving reduces the ice thickness, levels the ice, brightens the lines and markings, and reduces compressor run time. The easiest way to tell when a major shaving is required is by observing how faded the lines are.

Ice thickness can be determined by chipping ice away with a sharp ice pick. This should be done gently so that large chips are not taken out of the ice. Normally, 3/8 to 1/2 in. (10 to 13 mm) of ice should be maintained above the lines.

Ice thickness can be determined in two different ways, depending on the type of floor construction. A battery operated hand drill with a small bit is best for surfaces with a concrete base. For arenas with a refrigeration floor of sand, build your ice within 1/16 in. of the desired thickness. Then mark your ice with spray paint at the desired locations. During ice shaving, the disappearance of these marks will show you when the ice is at its proper thickness. These marks should be visible to the operator only, and therefore kept as small as possible.

First, determine the various thicknesses of ice above the lines at the 23 points illustrated by asterisks in the figure. This assumes your ice was level when the lines were installed. As some rinks do not have level floors, the thickness below the lines may vary, but it is important to keep the thickness above the lines constant.

Start by shaving around the outside of the rink with the ice edger until the desired depth is reached.

Follow this pattern for shaving edges.

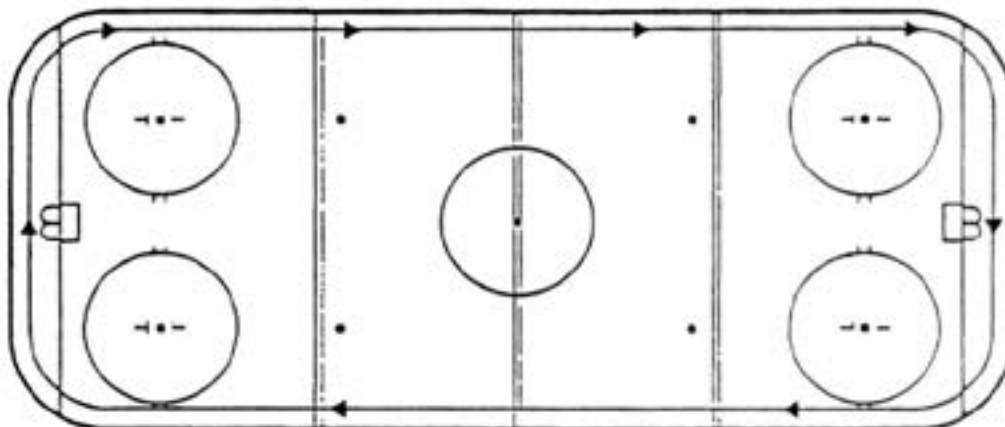

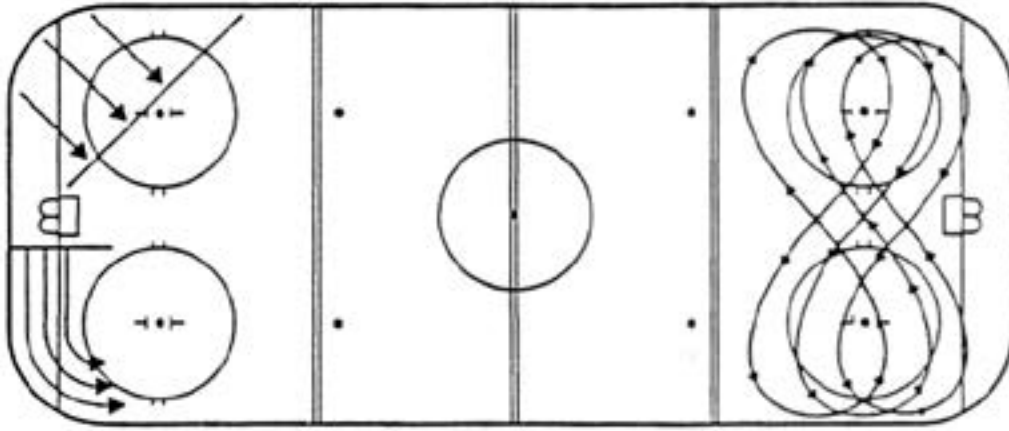

Follow these patterns for shaving corners.

Do not try to cut too much at once. The edger will only cut 3/8 in. (10 mm) deep.

Next, take the resurfacer around the rink cutting 1/16 in. (1.5 mm) at a time. Shave until the ice is cut down to the same level established with the edger. Use overlapping figure eights Then follow the curve of the boards around the top half of circles and run at 45 degrees across the circles. The final step is to follow large overlapping figure eights to level ripples.

The number of times a specific pattern is repeated in an area of the ice surface will depend on the amount of ice to be removed. Remember to constantly check ice thickness to avoid shaving off too much ice.

After a major shaving, there may be an insufficient thickness of ice over the lines and markings. This may have been necessary to level the ice or to remove all of the dirty ice. You will then have to build the ice back up to 3/8 to 1/2 in. (10 to 13 mm) above the lines to protect the lines and markings from skates and from the resurfacer blade.

Use the resurfacer or a hose.

If you use the resurfacer, remove the rag and raise the resurfacer off the ice 2-3 in. (50 - 75 mm). This will allow the water to run and find its own level.

Before you start shaving, give yourself enough time to carry out the work required. For reference, here are some guidelines on the amount of time you might need:

- Shaving 1/16 in. (1.5 mm) will take one person between one and one-and-a-half hours.
- Shaving 1/8 in. (3.0 mm) will take one person three hours.
- Shaving 1/4 in. (6.0 mm) and levelling edges and corners will take one person between five and six hours.

A tractor drawn re-surfacer will require more time.

Follow this pattern for levelling ripples after you have shaved the corners.

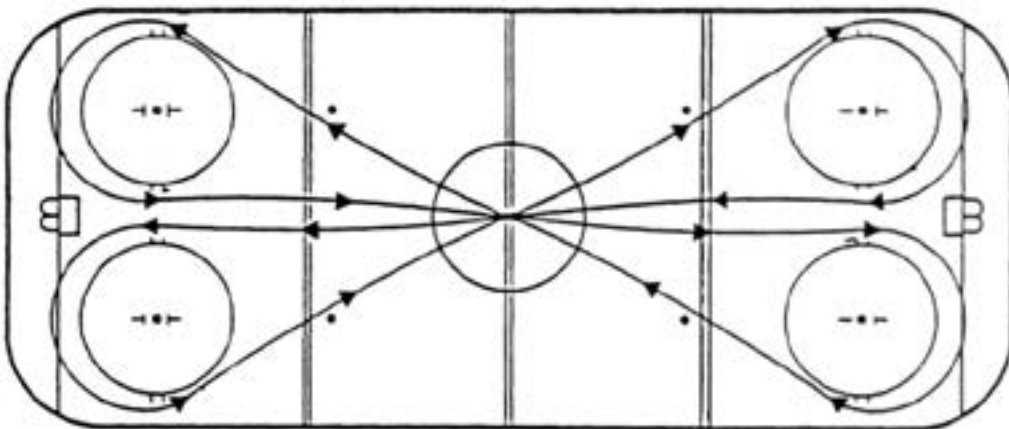

## Refrigeration

Proper maintenance and operation of the refrigeration equipment and system saves money. Equipment that lasts a long time will not need to be replaced, delaying costs. Properly operating equipment is efficient, uses less energy while operating, and does not need to run as many hours. If equipment is not operating as long, it lasts longer. As the advertisements put it: “You can pay me now, or you can pay me later.”

The following section is taken primarily from the Ontario Arenas Association Inc. publication on “Refrigeration and Ice Making” March 1988 printed by the Aylmer Express Ltd. It also draws on material provided in part by Lewis Cimco Refrigeration Products. See also Arena/Curling Rink Management & Operation, Level 2, published by Manitoba Culture & Heritage in February 1986.

The essence of a rink or arena is the ice. It is critical to the successful operation of your facility that the refrigeration systems be properly operated and maintained. Follow these procedures to maintain an efficient system throughout the entire year.

### CAUTION

**Draining oil from ammonia refrigeration systems is a potentially dangerous process. It should be performed only by properly trained personnel.**

### Start-up of refrigeration systems

Start-up season is a very busy period where you need to pay attention to a great many details. It may be necessary to call in commercial service personnel to assist with some of these procedures.

#### Pre-start-up

- Check brine level and measure its strength using a hydrometer. Aim for a specific gravity of 1.22 at -20 F (-29 C). If the brine is too strong it will increase friction and require more power. If it is too weak, the chiller will freeze. A lack of brine allows air to enter and introduce corrosion.
- Drain chiller of oil (before brine pump is started).
- Drain oil from compressor, remove crankcase cover, flush all dirty oil from compressor oil ways, clean or replace oil filter, wipe out with lint free rags, clean oil sight glass, reinstall cover, and refill with proper oil.
- Check seal on brine pump, spin shaft for tightness check.

- Drain water tank of condenser, clean out sludge, and refill.
- Check seal on water pump, spin shaft, and clean strainer if used.
- Run water pump and check water sprays on condenser. Note and record operating pressure.
- Grease exposed water and brine valve stems.
- Flush water-cooled condenser, possibly take off heads OR manually open regulating valve.
- Check V belts for tension, wear, cracking, and alignment. Don't forget the evaporative condenser fan belt outside.
- Check couplings for wear and looseness.
- Turn oil filter “T” handle on Ammonia V/W mechanical filter.
- Grease or oil bearings on motors, pumps, fans, and condenser shaft.
- Check pH of brine for control of corrosion.
- Check condition of headers and mains. Paint if rusty.

Ammonia compressors should be opened for internal inspection every 8,000-10,000 hours of operation. All worn parts should be replaced at this time. Freon compressors generally require much less frequent maintenance.

#### Actual start-up – single compressor

- Check belts for tightness and alignment.
- Open discharge valve on compressor and condenser inlet.
- Open liquid drain on condenser.
- Check whether water supply to condenser is okay.
- Open suction valve on compressor.
- Check oil level in compressor and external lubricator if so equipped.
- Open king valve one turn (if applicable) or main suction valve on chiller.
- Start compressor.
- Check oil level and pressure.
- Check suction and discharge pressures.
- Check water supply through compressor jacket and heads. Open manual valve if it is so equipped.
- Open king valve fully.
- Slowly open suction valve until fully open. Do not overload compressor motor.
- Check refrigerant level.

If a brine chiller is the evaporator then establish a flow of brine through chiller first.

**Actual start-up – two or more compressors, including mop drum on evaporator; follow the pre-start procedures for a single compressor, then:**

- Turn on water to condenser and compressors.
- Check that all brine valves are open.
- Start the brine pump manually.
- Start the condenser fan and condenser pump manually.
- Close oil separator valves on all compressors.
- Close the suction control valve located between chiller and compressor (usually on line from surge drum).
- Open suction and discharge stop valves on compressor #1.
- Crack open suction control valve very slightly.
- Start compressor #1.
- Adjust suction control valve to 25 psig (175 kPa). Allow to stabilize.
- Open suction and discharge stop valves on compressor #2.
- Start compressor #2.
- Adjust suction control valve to 25 psig (175 kPa). Allow to stabilize.

Follow the same procedure as #1 and #2 if a third compressor is involved.

As brine temperature falls, suction pressure will decrease. The suction control valve should be opened to maintain 25 psig (175 kPa) until the valve is fully open.

Oil separator valves should be checked shortly after start-up. If, when the valves are cracked open, frost appears on the line to the crankcase, the valve should be closed again to prevent ammonia build-ups. When no frost appears, valve can be fully opened.

**Daily checks after start-up**

- Maintain an operating log.
- Check oil level in compressors.
- Check for leaks of water, oil or refrigerant.
- Check brine level. If it is too low, check for leaks; too high; air in system.
- Check operating pressures
  - Suction;
  - Discharge;
  - Oil pressure;
  - Brine pump;
  - Water pump.
- Listen to noise level of machinery.
- Check refrigerant level.
- Check water tank for water level, dirt and the build-up of solids
- Look out for short cycling of machinery such as compressors, pumps, and fans.
- Note compressor high and low pressure changes. Fuse burn-outs are an indication of short-cycling.
- Check operating temperatures
  - Suction;
  - Discharge;
  - Oil;
  - Brine;
  - Water tank;
  - Water off compressors.

**Periodic maintenance**

- Draw oil from chillers and compare logged consumption with amount drained out. Amounts should be equal. Nothing is lost, burned, or destroyed except by leaks.
- Check water sprays on condenser.
- Clean strainers.
- Check belt tensions.
- Check couplings for wear.
- Check for oil, water or refrigerant leaks.
- Check refrigerant levels.
- Check oil levels.

## Annual shutdown – general

Since many skating and curling rinks do not operate their refrigeration systems for the full year, and are shut down for varying lengths of time, there are a number of steps that must be completed to ensure safety and the continued proper operation of a refrigeration system.

It is easiest to shut down the system immediately after the last rental of the ice. At this point, the system is still running and the suction pressure will be normal.

On a rink with a high pressure receiver, close the king valve and pump all the freon or ammonia back into the receiver. On a rink with no high pressure receiver, this is not required. On a rink with a flooded floor, close the suction valves to the liquid pumps, switch off liquid pumps, then pump all the refrigerant back to the low pressure receiver.

Turn off control switches for all compressors, brine pumps, condenser fans and pumps.

Open the main disconnect switch for the entire system.

Close compressor suction, discharge, oil drain, and liquid feed, if so equipped.

Valves that have been closed should be clearly tagged and a notice to this effect attached to the main disconnect switch. As an added precaution, remove fuses from the panel.

At this point the compressors still have pressure inside. The oil can be drained using this pressure.

After the oil is out, the refrigerant will start to come out. In an ammonia system, the gas can be purged into a pail of water. When the bubbles have nearly stopped, remove the hose from the water.

After the refrigerant has been purged from the compressors, close the valve. Do not leave the compressor open to the atmosphere.

Be sure the system is left in a safe condition. Check for leaks. Recheck all items listed above.

The system is now ready for preventive maintenance.

## Preventive maintenance

The time to carry out preventive maintenance both on the compressor and other parts of the refrigeration system is during the shutdown period. If the system incorporates an evaporative condenser, it should be inspected during shutdown.

- Inspect the condenser coil for scale build-up.
- Flush out the sump tank thoroughly, along with the remote balance tank.
- Inspect the condenser spray system for plugged or damaged nozzles.
- Oil or grease all bearings and other moving parts, as required by the manufacturers' instructions.
- Inspect V-belts. Replace if necessary.
- Drain compressor crankcase oil. Remove hand hold covers and flush out the interior of the crankcase before recharging with fresh oil. Use only refrigerant oil of the proper grades recommended by the compressor manufacturer.
- Under normal operating conditions, open the compressor(s) for an internal inspection every 8,000-10,000 hours. Check all suction and discharge valves, connecting rods, and bearings. Replace as required.
- Turn over the brine pump at least once a month during shutdown to break up the calcium deposits that tend to form on the seal faces when the water evaporates. If you do not perform this maintenance, the deposits could ruin the seals on start-up.
- Once a year drain a sample of the brine and send it for analysis, for specific gravity and pH. Specific gravity is readily obtainable through the use of the hydrometer provided with the system. The pH value is a measure of the acidity or alkalinity of the brine. It should fall between 7 (neutral) and 9. If the value varies much outside this range, the brine will tend to corrode the internal surfaces of the metal parts, resulting in leaks and a build-up of sludge in the system. Suppliers of the corrective inhibitors will carry out this analysis and recommend suitable treatment, based on the volume of brine in the system. In most cases the suppliers of the initial calcium charge in either flake or bulk will provide the correct inhibitors for the system. So it is only the annual follow-up which is required. Should the specific gravity be above or below design, it can be corrected.

## After shutdown

- If pressure rises above 25-50 psi, pump down or bleed off residual pressure in the refrigeration system.
- Drain water from compressor and condenser system.
- Check brine levels and fill if necessary.
- Grease brine and water valve stems.
- Grease or oil bearings.
- Slacken “V” belt tension.
- Periodically during shut down (especially two to four weeks or after first warm spell):
  - Check compressor pressures;
  - Check brine level;
  - Spin shafts of pumps, motors, compressors;
  - Look for oil leaks;
  - Test for refrigerant leaks.

## Leak detection

Here are several methods of detecting leaks of ammonia and freon.

### Ammonia

Litmus paper. Wet litmus paper turns a reddish colour when in contact with ammonia. Burning sulphur stick. A burning sulphur stick will give off a white smoke when near ammonia. Soap bubbles. Use a soap and water solution to look for bubbles.

### Freon

Halide torch. The flame of a halide torch will turn green around its edges when Freon is burned. Electronic leak detector. An electronic leak detector will chirp or tick like a geiger counter when placed in Freon vapours. Soap bubbles. Use a soap and water solution to look for bubbles.

## Charging oil to a system (adding oil)

Since a compressor’s crankcase is at suction pressure, it is not possible to add oil without mechanical means. Use a simple hand oil pump. The hand pump fits into a 5 U.S. gallon (20 litre) can of oil, and a flexible hose runs from its outlet connection to the oil charging valve on the compressor.

The hose is first tightened on the pump connection and with the other end loose, oil is pumped by pulling up on the pump handle. When oil squirts out of the loose connection on the compressor, you have purged out the air and that end of the charging hose can now be tightened. The oil charging valve on the compressor can then be opened and oil pumped in. Observe the oil level in the crankcase by looking into the sight glass on the compressor crankcase.

## Draining oil (ammonia system only)

Refrigeration systems are closed systems. Nothing is consumed except that which is lost through a leak. As a result, all oil pumped into a compressor winds up in the evaporator.

If a log is not accurately kept indicating the quantity of oil added to the compressor or drained from the evaporator, the frequency and persistence of oil draining becomes suspect.

To drain oil from an evaporator, turn off the source of heat entering the evaporator and let the boiling action subside. If you are using a blower type of evaporator, turn off the brine pump or air fans.

You can usually find an oil drain valve on the lowest point of an ammonia evaporator. As long as the suction pressure is above zero psi (0 Pa), simply opening the drain valve will force out the oil. Oil is heavier than ammonia so it settles out on the bottom. If the valve is opened too wide, the ammonia pressure will “blow” a hole through the oil and give a false reading of no oil or the ammonia will be drained out.

The oil comes out in a thick, creamy white foam similar to shaving cream. Allow it to settle and record the amount of liquid removed, not the foam volume.

## Charging brine

Since most artificial ice plants are closed systems, adding brine usually means more than just pouring some in. Brine is added with the help of suction produced by closing off the main valve slightly on the pump suction side.

### CAUTION

Do not close the valve too hard or the pump will cavitate. When this happens, the pump will become noisy and probably suffer physical damage.

The pump suction then falls into a slight vacuum. There is another smaller valve between the main pump suction valve and the pump itself. Place one end of a hose on this charging valve. Immerse the other end in a brine barrel. By opening the charging valve, you will draw brine into the system. When the brine reaches the recommended level in the expansion tank, the main suction valve on the pump should be fully opened.



## Trouble analysis for refrigeration systems

Problems in the refrigerant system that create high discharge pressure will often increase the load on the compressor unnecessarily. This wastes energy and could cause premature failure of system components if not properly handled.

The following lists symptoms, their probable causes and solutions. If you are in doubt about any procedures listed, contact a qualified refrigeration mechanic for assistance.

Problem	Probable cause	Remedy
<b>Low suction pressure</b>	Low refrigerant charge Dirty liquid strainer Faulty head pressure float Improper brine density  Low brine flow	Repair leak and add refrigerant. Clean strainer. Inspect and repair. Check specific gravity and strengthen as required.  Check position of valves.
<b>High discharge pressure</b>	Condenser fan inoperative Condenser pump inoperative Plugged water nozzles Scaled condenser tubes Condenser filled with liquid  Air in the condenser  Excessive wet bulb temperature	See electrical checks below. See electrical checks below. Clean nozzles. Acid clean. Check piping, liquid strainer, and floats. Purge at liquid header if operating or gas header if shut down. Increase quantity of cold make-up water.
<b>Compressor shutdown</b>		
- <i>On low suction pressure</i>	See above	See above
- <i>On high discharge pressure</i>	See above	See above
- <i>On oil pressure control</i>	Lack of oil in compressor Faulty oil pump Plugged oil strainer Refrigerant in crankcase	Add oil Replace pump Clean strainer Drain refrigerant and oil. Recharge with fresh oil.
- <i>On high discharge temperature</i>	Excessive discharge pressure Excessive compressor ratios Broken discharge valves Lack of head cooling	Check condenser operation. Check operating conditions. Replace valves. Adjust cooling water flow.
- <i>On high oil temperature</i>	Lack of oil cooling Broken discharge valves	Adjust cooling water flow. Replace valves.

<b>Problem</b>	<b>Probable cause</b>	<b>Remedy</b>
<b>High brine temperature</b>	<p>Low refrigerant charge</p> <p>Broken suction valves</p> <p>Load above design</p> <p>Improper brine flow</p>	<p>Add refrigerant.</p> <p>Replace valves.</p> <p>Reduce load.</p> <p>Check valves.</p>
<b>High oil consumption</b>	<p>Faulty oil return float</p> <p>Check main disconnect</p> <p>Check on-off switch</p> <p>Check power fuses</p> <p>Check control fuses</p> <p>Check thermostat</p> <p>Check overloads</p> <p>Check emergency stop switch.</p>	<p>Inspect and repair.</p> <p>Normal position auto.</p> <p>Selector switch in manual position bypasses.</p> <p>Replace blown fuse.</p> <p>Replace blown fuse.</p> <p>Push re-set button, check setting.</p> <p>Reset if tripped.</p>
<b>Compressor off</b>	<p>Check on-off switch</p> <p>Check power fuses</p> <p>Check operating and safety control.</p>	<p>Push re-set button where applicable.</p> <p>Replace blown fuse.</p>
<b>Condenser fan off</b>	<p>Check on-off switch</p> <p>Check power fuses</p> <p>Check setting of press control</p> <p>Check overloads</p> <p>Check remote lock off switch</p>	<p>Replace blown fuse.</p> <p>Push re-set button and check setting.</p> <p>Reset.</p>
<b>Condenser water pump off</b>	<p>Check on-off switch</p> <p>Check power fuses</p> <p>Check setting of press control</p> <p>Check overloads</p>	<p>Turning selector switch to hand position bypasses automatic control.</p> <p>Replace blown fuses.</p> <p>Push reset button and check setting.</p> <p>Reset.</p>

## Trouble shooting

- **Compressor won't start**

Check power, fuses, overload resets.  
If a fuse is replaced be sure it is with an identical type.

Check if brine pump runs.

Check oil level in compressors.

Check refrigerant level.

Observe high and low pressure gauges.

Push manual resets on high pressure and oil pressure cutouts and note which one starts compressor.

- **If oil pressure switches reset starts**

Check for oil foaming.

Check for oil pressure and fluctuation.

**DON'T PUSH RESET AGAIN. YOU COULD SEVERELY DAMAGE THE COMPRESSOR.**

- **If high pressure switch reset starts**

Check fan belt on condenser.

Check water level in tank.

Check water pump operation (note pressure gauge).

Check condenser sprays.

Check condenser air inlets (poplar fluff is a common culprit). Note pressure on operating gauges.

Check fuses, power, O/L resets, etc.

- **Soft ice but equipment operating**

Compressor problems (worn parts, etc.).

Brine pump problems (poor flow, restriction, worn).

Ice thickness is too large.

Brine temperature too high—possibly too much oil in chiller or improper thermostat setting.

- **Compressors running hot [over 275 F (135 C) discharge temperature]**

Check operating (suction and discharge) pressures average: 25 and 165 psi (175 and 1140 kPa), extremes 15 and 195 psi (100 and 1350 kPa).

Check jacket cooling water supply and flow and temperature.

Broken valves, could be noisier than normal.

- **High oil consumption**

Faulty oil separator float (mechanic only should check).

Oil return valve closed.

- **Brine pump will not run**

Incorrect setting of thermostat.

Brine temperature adequate.

O/L reset, fuses, power.

## Safety practices

- Know where the main electrical disconnect switch is located.
- Know where the main natural gas shut-off valve is located.
- Make certain that exhaust ventilation equipment is adequate and maintained in operating condition.
- Disconnect electrical equipment while you are working on it.
- Provide a long rope for tying to a person entering a room likely to be filled with any refrigerant. The rope will serve as a guide for his exit and for use in attempting to follow and locate the person in the room. Never go into a room with heavy concentrations of ANY refrigerant without another person nearby.
- Provide emergency lighting, proper exits, gas masks, and spare gas mask canisters.
- Monitor the compressor discharge temperature and the lubricating oil temperature. Maintain within the manufacturer's prescribed top limit. Stop the compressor and determine cause if the top limit is exceeded.
- Avoid standing on piping. Eliminate excessive piping vibration immediately.
- Maintain guards on belt drives and direct driven equipment.
- Maintain relief valve piping to a diffuser located outside.
- Never valve off a vessel filled with liquid refrigerant, unless it is protected with a properly sized relief valve. Never expose refrigerant vessels, drums, or bottles to excessive heat.
- Liquid refrigerant pumps should have properly sized relief valves, whether of the positive or centrifugal type, to protect against excessive pressure.
- Use a "buddy system" for personnel making repairs in refrigerated rooms and engine rooms.
- Develop an "emergency procedures plan" and arrange for rehearsals and training of personnel in the plan. Know the location of: main liquid line shut off valve (King Valve), compressor shut off switch, and water hose.
- Make sure fire extinguishers are in operating condition and that sufficient numbers are available in the right places.
- Always wear a gas mask when making repairs in an area where a leak OUGHT to occur.

## First Aid

KEEP AN IRRIGATION BOTTLE READILY AVAILABLE CONTAINING 2 1/2 PER CENT EACH OF BORAX AND BORIC ACID IN DISTILLED WATER.

## Gassing

- Remove affected personnel to fresh air immediately.
- Summon a doctor.
- Remove clothing if splashed with liquid or impregnated with concentrated vapour.
- Keep the patient still and warmly wrapped with blankets.
- If conscious and the mouth is not burned, give hot sweet tea or coffee.
- Oxygen may be administered by a person authorized by a doctor.
- If breathing fails, apply artificial respiration.

## Liquid splashes or concentrated vapour in the eyes

- Irrigate eyes immediately with a solution of 2.5 per cent each of borax and boric acid in distilled water. Continue for at least 30 minutes.
- Summon a doctor.

## Skin burns from splashes or concentrated vapour

- Wash immediately with large quantities of water and continue for at least 15 minutes, removing all clothing while washing. (Shower bath or water tank should be available near all bulk installations).
- Summon a doctor.
- After washing, apply wet compresses (solution of 2.5 per cent of borax and boric acid in distilled water) to affected parts until medical advice is available.

# 10. Project planning

This section looks at the steps that should be undertaken when planning a building or maintenance project for a typical rink or arena. With minor adaptations, the procedure should work for nearly any major investment. It was written primarily with the needs of the management committee in mind.

It considers the renovation of existing facilities, addition of new areas to existing facilities, and the construction of an entirely new facility, discussing typical construction costs and relating them to practical examples.

Treat the facilities and projects as rental properties, using a business model to generate a profit. If your committee sets your profit goal at zero or less, that's your business. Provide an appropriate place for that option.

The energy efficiency and energy management ideas presented throughout these guidelines should form part of the planning process in your facility, now and in the future.

## Project concept

Start with the assumption that somebody out there has a good idea for a project – anything from a whole new building, to an addition, to a renovation or maintenance type job.

In many instances management and building committees will be established to nurture or kill ideas that are brought forward. In the absence of these groups, the idea person(s) must develop the concept. Either way, think of the following factors that should be considered for the idea.

## Demand forces

Define the forces that are creating a demand for your project.

- Who will use the project?
- What will they pay to use it?
- What features will they want?
- How soon do they need it?
- Can you do it profitably?
- How will it affect other programs?

To answer these basic questions and many more, you must do your homework and learn more about your facility and your market.

## Economic base analysis

You need to determine the economic and demographic forces that will shape your decisions.

An overall analysis of your community is an excellent point of departure for your study. If the community is weak, exhibiting a decline in economic vitality, financing will be difficult to secure. If your community is strong, with economic growth and a solid base of employment, financing should be attainable.

**Demographics.** There are two simple rules to be aware of when studying the demographics of your community.

If you were not born; you don't count. Every decade you age EXACTLY 10 years.

Everything else flows from these basic principles!

Is the population of your community increasing or decreasing? Look at your community, your district. What age brackets are increasing and which are decreasing?

For example, if you are considering a hockey rink and the males age six - 39 are on the decrease, your analysis should project a future demand that is less than current levels.

On the other hand, if you are looking at a curling rink and the group ages 30 - 69 are steadily increasing, then your projection should suggest an increase in future demand from current levels. Sounds simple, right? Remember that those 20 - 29 year olds will be 30 - 39 year olds in ten years.

Population statistics for most communities are available from the census bureau Revenue Canada and Statistics Canada.

**Employment.** Who will pay? If you expect people to pay for the benefits that they receive from using your facility then they will need a stable income.

On a community basis you must look at employment levels, historical employment levels, and expected changes in total jobs. Unemployment statistics can be misleading, so try to obtain data that lets you know how many people are working in your community and your district.

Your knowledge of the community will be necessary to analyze any “unique” factors influencing the employment prospects of your town. Look at local employers. Is your community dependant on one or a few industries? How would a work stoppage affect things?

Consider a simple example. In 1988 the Town of Hudson Bay replaced a fire damaged ice rink facility with a new \$1.2 million expanded facility. In 1990 the town’s largest employers pulled out, the population dropped, and income to the community fell. If this could have been forecasted, some decisions may have been made differently.

**Income.** The average income level of the people in your district is available from Statistics Canada. This data will help you to make decisions on the public’s ability to support your facility both in terms of user pay benefits and for general fundraising (if applicable).

Even though your population statistics indicate a strong demand for services, if the people in your town can’t pay for these services then chances are you won’t be in a position to provide them.

Examine the case where a community has a large number of people with a very low average income. Those individuals will only be able to afford modestly priced services. Don’t plan on much beyond recreational hockey, public skating or recreational curling.

**Competition.** To evaluate your competition you must consider all factors involved in the average person’s decision to support your facility. Only then will you know who your competition is.

If your town doesn’t have a rink or an arena, that doesn’t mean you don’t have any competition. What you are really selling is leisure, recreation, sports and entertainment, and maybe even more. Let’s look at both direct and indirect competitors.

Direct competitors consist of facilities that provide the same services you propose to provide. Other rinks and arenas:

- in your district \_\_\_\_\_
- within 50 km \_\_\_\_\_
- within 100 km \_\_\_\_\_

Indirect competitors consist of alternate sources of leisure activities in your marketplace. They may include:

- Bowling alleys
- Malls
- Movie theatres
- Pool halls
- Swimming pools
- Restaurants
- Community halls
- Tennis clubs
- Bars and taverns
- Dance clubs
- Television

Your customer has a finite supply of time and money. You must convince yourself, your banker, and the public that some of the people’s time and money will be spent at your facility.

Each of these indirect competitors takes people’s time and money and holds a certain number of people away from your facility.

**Unique circumstances.** Does your community have some other unique factors that will enhance the viability of your project? Are there unique opportunities that could be pursued to enhance a project’s worth?

Seek out special circumstances. If a new or improved recreational facility could be built, would people be attracted to relocate into your area? Would it sway a large employer to locate in your town instead of somewhere else? Would it keep the town vibrant, attracting young families to shop in the local stores after little Billy’s hockey game?

Look at the availability of land and the availability of services for your project on an easily accessible site. There may be good land 10 km from town but 5 km from natural gas or power. Servicing costs would probably make the project impractical.

Look at reducing costs by sharing facilities or expanding your services to incorporate other needs. If a rink was located near the local school and the students used it during the day as part of their physical education, your utilization and revenue would increase. If you can provide a meeting room for a local senior citizen's group, thus renting out more than just ice time, your idea may come closer to reality.

Examine the other groups, organizations, service clubs, and institutions in your community. Look for joint opportunities, you'll find some. An existing facility has basic overhead costs that must be covered by the basic operation of the facility. Increasing the use of the building for meetings, shows, concerts, weddings, and clubs increases revenue, increases utilization, but only marginally increases total operating cost.

**Political developments.** For lack of a better name, politics occasionally create situations that influence the viability of certain projects. Grants, loans, subsidies, and the like are made available at certain times for a variety of reasons and purposes. Watch for them and use them if practical – once you know all the facts and implications.

Don't count on using grants alone to pay for new projects. As many communities can attest to, grants can be withdrawn or modified, creating severe difficulties for unprepared organizations.

## Market needs

Your project must fulfil a need of the society you plan to serve. To be successful you must provide that service better than your competition at a price that people are willing to pay and that meets your cash flow requirements.

Once you have determined the need you will fill, established the people who will benefit from it, figured out who the competition is, and tied down a good location, it's time to talk about money.

## Planning process

In the beginning there is nothing except an idea.

At this point there are no constraints and no limitations. Anything is possible.

Then reality sets in. Budgets are limited, costs are prohibitive, your site is only so big, and retractable roofs don't work well at 40 below. The planning process shapes those good ideas into practical solutions.

**Organization.** It is important to establish early how decisions are to be made and who will make them. This often consists of a building committee with an appointed chairperson. Occasionally there is a parallel committee responsible for financing and fundraising. Together you have one committee raising money while the other committee spends it.

This approach has been particularly successful in hospitals, nursing homes, universities, and similar public service institutions. A review of how these organizations raise money is certain to help you raise money, but will not be covered in these guidelines.

It is very important to establish the procedures to be followed by the building committee.

- Who do they report to?
- Who has the final say in decisions?
- What records must be kept?
- What is the schedule?

If your project is a small one the whole job may be delegated to one person. For example, you might ask Joe, a person you trust, to get the public address system replaced. You'll want him to look at P.A. systems in buildings in the vicinity, talk to system suppliers and electricians, get prices from two or three contractors and report to the Board of Management in one month.

Joe knows what to do, what information to collect, and he has a timetable in which to do it.

**Elements of planning.** To take the idea and make it a reality requires a few basic steps.

- Analyzing need
- Collecting solutions
- Reviewing alternatives
- Establishing budgets
- Establishing costs
- Priorizing options
- Planning options

These basic elements of the planning process apply to any size and type of project. As the project grows in size and complexity, so will the process of producing a final solution grow in size and complexity.

At some time every owner needs the help of professional planners. These include architects and engineers who specialize in the design of rinks, arenas and recreation buildings. Their training and experience will assist in the planning process. In most projects funded by public money or over a certain dollar value, the use of professional engineers and/or architects is a legal requirement to satisfy funding rules and provincial bylaws. The Provincial Architects Association and engineering associations will be pleased to forward the names of qualified firms.

Also good sources of basic information are contractors, wholesalers, distributors, manufacturers, and other sales organizations.

Talk with other facility owners to learn about their experiences. You can benefit from their successes and avoid their mistakes.

**Planning options.** When you are considering a project, you must review some options such as: to build new; to replace, to repair, to renovate, or to add-on.

Virtually every need will be fulfilled by one or more of these options.

## Planning for energy efficiency

When considering energy efficiency projects, you are dealing with a different type of need. First consider a need to save money—financial need. Second, consider a need to save energy—an environmental need. The analysis of these needs requires a full understanding of some financial concepts.

### Cost avoidance

If your current monthly electricity bill is \$2,000/month and you are planning an energy efficiency project that will save \$500/month, you are looking at avoiding future electrical costs of \$500/month. This is referred to as cost avoidance.

The trouble with cost avoidance is that it never shows up anywhere. You will never get a cheque, never a credit, nothing to tell you that you just saved \$500. But the savings are real. Without your energy efficiency project, the \$500 would be in Manitoba Hydro's bank account, not yours.

### Inflation

In energy efficiency projects you can assume that energy prices escalate at a rate from 0 to 5 per cent per annum.

Assume that a budget is established to pay the utility bills at that steadily increasing level. When you do your analysis of an energy efficiency project the savings show up as the difference between the budgeted utility costs and the projected utility costs. The savings must be large enough to justify the cost of your energy project.



Using the previous example of \$2,000 a month current costs and a cost avoidance of \$500/month, and assuming an inflation rate of 5 per cent, the inflated values will be as listed in the following table:

### Effects of inflation on cost avoidance

Year	Electrical bill before	Electrical bill after	Cost avoidance
1	\$2,000	\$1,500	\$500
2	\$2,100	\$1,575	\$525
3	\$2,205	\$1,654	\$551
4	\$2,315	\$1,736	\$579
5	\$2,431	\$1,823	\$608

The effect of inflation is that cost avoidance is also inflated because future costs will be inflated so the savings increase at an identical rate.

### Financial analysis

Financial analysis is covered in Section 3.

When examining the finances of your project, remember that inflation has an effect on the future value of the money that you are using to pay your financing cost or energy costs. This is referred to as the net present value of money; as discussed in Section 3.

To help you get a feel for the relative cost of different construction and repair options, consult the following table of work and related costs. These costs are based on 2,000 prices in Manitoba and should be checked based on actual costs at the current time in your location. An architect, engineer, or contractor will be able to help you with current pricing.

### Typical repair and replacement costs

(2,000 prices for Manitoba)

Replace existing hockey rink concrete floor with new concrete floor including hot deck. \$330,000

Replace refrigeration compressor (ammonia)

50 ton	\$23,000
60 ton	\$28,000
75 ton	\$32,000
100 ton	\$40,000

Replace brine pump

10 hp	\$ 5,000
15 hp	\$ 6,000
20 hp	\$ 6,500

Replace evaporative condenser (ammonia)	
50 ton	\$26,000
60 ton	\$30,000
75 ton	\$35,000
100 ton	\$48,000

Renovate public areas  
\$100/ft<sup>2</sup> (\$1,076/m<sup>2</sup>) of floor area

Renovate wash/change rooms  
\$125/ft<sup>2</sup> (\$1,345/m<sup>2</sup>) of floor area

Add R-15 to exterior wall  
Stud wall \$5/ft<sup>2</sup> (\$54/m<sup>2</sup>) of wall

Masonry wall \$20/ft<sup>2</sup> (\$215/m<sup>2</sup>) of wall

Add R-20 to roof  
Attic (blown insulation) \$1/ft<sup>2</sup> (\$10/m<sup>2</sup>) of roof

Inverted roof \$15/ft<sup>2</sup> (\$161/m<sup>2</sup>) of roof

Flat \$50/ft<sup>2</sup> (\$538/m<sup>2</sup>) of roof

Sloped metal \$75/ft<sup>2</sup> (\$807/m<sup>2</sup>) of roof

Install low-e ceiling \$30,000

Demineralized water \$18,000

Brine pump with VSD \$17,000 - \$20,000

### Typical costs of new construction

New hockey rink 24,000 ft<sup>2</sup>

new rink with ice plant	\$850,000
new rink without ice plant	\$750,000

Ice plant for new rink including 5-in. concrete floor slab

(50 ton) winter only operation	\$100,000
(75 ton) year round operation	\$125,000

New curling rink with washrooms and lounge plus viewing areas:

	Building	Refrigeration
2 sheet	\$200,000	\$35,000
3 sheet	\$300,000	\$45,000
4 sheet	\$400,000	\$50,000
6 sheet	\$600,000	\$55,000

Extra public area \$75/ft<sup>2</sup>

Extra rink/warehouse area \$20/ft<sup>2</sup>

Mezzanine space \$50/ft<sup>2</sup>

Architects and engineers: 8 per cent of construction value

## Planning check list

### Phase I – NEEDS ANALYSIS

#### Establish need for service:

- Address unmet needs.
- Meet competition with better service.
- Location.

#### Consider competition:

- Who is your direct competition?
- Where are they located?
- What other services are competing for your customers' time and money?

#### Demand forces:

- Population (growing, steady, declining).
- Employment (stable workforce, transient).
- Income level (high, average, low).
- Unique factors.

#### Finances and grants:

- Budgeted expense.
- Loans and mortgages.
- Grants.
- Cost of service.
- Operating and maintenance.
- Price for service.
- Local fundraising.
- Local operating grants.

### Phase II – PLANS AND SPECIFICATIONS

#### Scope of work:

- Define size of project.
- Define budget constraint.
- Establish time table.

#### Consultation:

- Building committee.
- Hire consultants as required.
- Talk to other owners.
- Talk to contractors.

#### Planning:

- Prepare preliminary floor plans.
- Re-examine project and financial plans.
- Prepare final plans.
- Look at the details of the project.
- Confirm that all needs are addressed.
- Check budget again.

#### Specifications:

- Establish quality expected.
- Establish energy efficiency goals expected.
- Communicate expectations clearly.

#### Tendering:

- Bidding:
- Sole source, negotiated.
- Invitational.
- Public tender.

#### Pricing:

- Cost plus (time and material).
- Fixed price.

### Phase III – CONSTRUCTION

#### Tender evaluation:

- Select contractor.
- Bid Bond - if required.
- Insurance during construction.
- Check references.
- Is it within the budget?
- Is contractor qualified?
- Construction schedule.

#### Pre-construction meeting:

- Prepare and sign contracts.
- Establish lines of communication.
- Establish limitations (if applicable).
- Establish payment procedure.
- Establish grievance procedure.

#### Construction:

- Review progress.
- Ensure that you get what you paid for, review workmanship.
- Communicate changes promptly.
- Try to keep changes to a minimum.
- Pay promptly once claims approved.

#### Post construction:

- Obtain maintenance manuals.
- Receive operator training.

# **APPENDICES**

- 1: Glossary of terms**
- 2: Reference publications**
- 3: Energy calculations**
- 4: Power factor correction**
- 5: Heat pumps for rinks and arenas**
- 6: Power Smart programs for commercial buildings**

# APPENDIX 1:

## Glossary of terms

**Air barrier.** A barrier usually consisting of a membrane to prevent the uncontrolled flow of air through the building envelope.

**Ambient temperature.** Temperature (usually of the air) surrounding operating equipment.

**Ammonia (NH<sub>3</sub>).** One of the earliest compounds used as a refrigerant.

**Ampere (A).** The unit of measurement of electric current.

**Atmospheric pressure.** Pressure exerted because air has weight. Under normal conditions this pressure is 14.7 lb./sq. in. (101.2 kPa).

**Basic monthly charge.** A fixed charge that pays part of the cost of providing dependable natural gas service. It does not depend on how much natural gas a customer uses. It helps pay for such things as the maintenance of meters and underground pipelines, and the cost of meter reading, billing and record keeping.

**Btu (British thermal unit).** Amount of heat energy required to raise the temperature of one pound of water one degree Fahrenheit. It is approximately the amount of heat generated by burning a common match.

**Btu/h (British thermal unit per hour).** See definition for Btu. Air conditioners are rated in Btu/h capacity.

**Building envelope.** The building exterior – including walls, roof, windows, doors, foundation, floor, insulation, vapour retarder and air barrier – that act as a unit to provide shelter and an indoor space.

**Calorie.** Amount of heat energy required to raise the temperature of one gram of water through a change of one degree Celsius. (8,604 kilo calories = 1 kWh).

**Capacitor.** Functions primarily to accumulate and store electrical charges. Used for power factor correction.

**Capital cost.** Initial cost of equipment and systems; purchase price, also known as first cost.

**City gate station.** The measuring station where a natural gas distribution company receives gas from a transmission company. Centra's City Gate is located at 1284 Wilkes Avenue.

**Compressor.** Takes a refrigerant vapour at a low temperature and pressure and raises it to higher temperature and pressure.

**Condensation.** Process by which a vapour is changed into a liquid without changing temperature.

**Condenser (general).** That part of the refrigeration system in which the refrigerant condenses and in so doing gives off heat.

**Conduction.** A method by which heat energy is transferred by actual collision of the molecules.

**Convection.** A method of transferring heat by the actual movement of heated molecules.

**Cubic metre (m<sup>3</sup>).** Unit of measurement for natural gas distribution in Manitoba.

**Dew point.** The temperature at which the air (space) becomes saturated. When air is cooled to the dew point, water vapour condenses into liquid form (provided its latent heat is removed).

**Demand.** Demand is the rate at which electric energy is delivered to a load. It is expressed in either kilowatts (kW) or kilovolt-amperes (kVA). Demand is the peak amount of power drawn through the meter during a specific billing period.

**Energy Efficiency Ratio (EER).** An indication of the efficiency of a unit such as an air conditioner. The higher the EER, the more energy efficient the unit.

**Evaporation.** The process by which a liquid changes into a vapour as a result of absorbing heat.

**Evaporator.** Device in the low-pressure side of a refrigeration system through which the unwanted heat flows; absorbs the heat into the system in order that it may be moved or transferred to the condenser.

**First cost.** See **Capital cost**.

**Footcandle.** A unit of measurement of usable light (illumination) that reaches any given surface. It is defined as one lumen spread over an area of one square foot.

**Gas main.** The portion of the main gas line that is installed underground and delivers natural gas to buildings on the street.

**Gauge pressure.** Pressure above or below atmospheric pressure.

**Gigajoule (GJ).** Equals one billion joules. A joule is a unit of energy used to measure energy content. One gigajoule equals 948,200 Btu or 278 kilowatt hours.

**Gigawatt (GW).** The unit of electrical power equivalent to one billion watts or one million kilowatts.

**Heat of vaporization.** The heat required to change a liquid into its vapour or gaseous form without changing temperature.

**Heat transfer.** The movement of heat energy from one place to another.

**Inverted roof.** Roofing system with water-proofing membrane under exterior grade insulation and ballast (gravel or paving stones).

**Kilovolt (kV).** The unit of electrical pressure, or force, equivalent to 1,000 volts (V).

**Kilowatt (kW).** The unit of electrical power equivalent to 1000 watts (W).

**Kilowatt hour (kWh).** The unit by which electrical energy is measured. For example, 10, 100-watt light bulbs switched on for one hour would use one kilowatt hour (1,000 watts for one hour).

**Latent heat.** That heat energy which causes a change of state without any change of temperature.

**Latent heat of vaporization.** Amount of heat to be added to (or subtracted from) one pound of the refrigerant to cause it to vaporize (or condense).

**Liquid line.** Runs from condenser to expansion valve, provides liquid refrigerant to the cooling process on the high pressure, high temperature side.

**Lumen.** A unit of measurement of light emitted by a lamp at the light source. A unit of luminous flux.

**LUX.** A unit of measurement of usable light (illumination) that reaches any given surface. It is defined as one lumen spread upon an area of one square metre.

**MBH.** 1,000 British thermal units per hour. A unit of power normally used for heating equipment.

**Megawatt (MW).** The unit of electrical power equal to one million watts or 1,000 kilowatts.

**Mercaptan.** The odourant added to natural gas to make it smell like rotten eggs.

**Natural gas.** A fossil fuel found deep in the earth. Its main component is methane (CH<sub>4</sub>). It is colourless, odourless and lighter than air. When burned it produces carbon dioxide and water.

**Ohm.** The unit of measurement of electrical resistance against the flow of electric current.

**Peak load.** Record of maximum amount of electricity used in a given time period.

**Power.** The rate of using electrical energy, usually measured in watts, kilowatts, or megawatts.

**Power factor.** The ratio of real usable power measured

in kilowatts to the total power (real and reactive power) measured in kilovolt-amperes.

**Primary Gas.** Natural gas received from Western Canada. It can be purchased on an unregulated basis from a natural gas marketer, or from Manitoba Hydro at rates regulated by the Public Utilities Board of Manitoba. The price Manitoba Hydro pays for its Primary Gas supply is passed directly on to the customer without any markup. During normal weather, this represents approximately 95 per cent of a customer's annual natural gas use.

**Radiation.** A method of transferring heat which uses energy waves that move freely through space; these energy waves may be reflected and/or absorbed.

**Receiver.** A container for storing liquid refrigerant.

**Reflectivity.** Ability of a material to reflect radiant heat energy.

**Refrigerant.** Substance which is circulated in a refrigeration system to transfer heat.

**Regulator.** An adjustable mechanical device that measures, restricts and maintains a constant downstream pressure of a gas or liquid.

**Relative humidity.** A ratio, expressed as a percent, of the amount of water vapour in an air space compared to the amount of water vapour that the air space could hold at a given temperature.

**Saturation.** The condition that exists when the space occupied by a vapour is holding as much of the vapour as it can at a particular temperature.

**Seasonal Energy Efficiency Ratio (SEER).** It is the ratio of the total cooling provided during the season in Btu divided by the total energy used by the system in watt-hours. The higher the SEER, the more energy efficient the unit. Also the EER of a unit averaged out over the heating or cooling season.

**Sensible heat.** The portion of heat energy used to warm or cool dry air from one temperature to another. Sensible heat plus latent heat equals the total heat energy required to change the temperature of air (excluding phase changes).

**Sublimation.** A change of state from solid to gas without going through the liquid state.

**Subcooling.** Drop in temperature resulting from the removal of sensible heat from a liquid.

**Suction line.** Runs from evaporator to compressor; returns the heat-laden gases from the evaporator to the compressor.

**Superheating.** A process resulting in a rise in temperature due to the addition of heat to the refrigerant vapour, either in the evaporator or the suction line.

**Supplemental Gas.** Natural gas that Manitoba Hydro purchases to ensure supply is available when demand is higher than normal. This usually represents about 5 percent of a customer's annual natural gas use. Supplemental gas costs fluctuate during warmer or colder than normal years.

**Thermostatic expansion valve.** Control valve which maintains constant superheat in the evaporator; also used for temperature control; operates on increased pressure resulting from a rise in temperature.

**Ton of cooling.** An old-fashioned term used to describe the cooling effect felt by melting one ton of ice in a 24-hour period. One ton of cooling equals 12,000 Btu/h.

**Torque.** Twisting force; usually expressed in foot-pounds or inch-pounds or (Newton-metre) computed by multiplying a force over the distance it is exerted.

**Transportation charge.** Cost of transporting natural gas to Manitoba, including pipeline charges and the cost of storage facilities where Manitoba Hydro stores natural gas purchased in the summer for use in the winter.

**Vapour retarder.** Previously and commonly referred to as the vapour barrier. Prevents the movement of water vapour through the building envelope.

**Volt (V).** The unit of measurement of electrical pressure, or force, which causes electric current to flow.

**Volt-amp.** Unit used to measure apparent power.  
1,000 Volt Amps = 1 kVA.

**Volt-amp resistance.** Unit used to measure reactive power. 1,000 VAR = 1 kVAR.

**Watt.** Unit used to measure real or useable power.  
1,000 watts = 1 kW.

## APPENDIX 2:

### Reference publications

The following is a list of a few publications that were reviewed during the preparation of this manual. These publications will provide additional information on the subjects listed. Most are available from the organization listed beside the title.

**American Society of Heating, Refrigeration, and Air-Conditioning Engineers. ASHRAE.**

2002 Refrigeration handbook

**BC Hydro**

Energy efficiency in recreation buildings – H651

May 90

Energy savings at ice rinks – C202 February 90

Case history – energy management in municipalities

December 85

**Canadian Electrical Association**

Energy management control systems, reference guide

Heat pump reference guide

Lighting reference guide

Electric variable speed drive reference guide

**Ontario Arena Association**

Design guidelines for energy conservation in skating rinks and arenas

Refrigeration and ice making publication, March 88

**Ontario Energy Network**

Volume 10, #2 – new refrigeration control saves energy and money, Winter 90

Volume 931 – Lease financing energy management projects, October 88

**Ontario Ministry of Energy**

Purchasing energy management advice

Energy conservation in existing arenas (three case studies)

**Saskatchewan Recreation Facility Association**

Air alert – toxic gases in community arenas

**TransAlta Energy Systems**

Energy conservation and management – a proposal for rink operators and managers

**US Department of Energy**

Energy conservation in ice skating arenas

## APPENDIX 3:

### Energy calculations

This appendix presents a brief introduction to energy calculations for operators of rinks and arenas.

Energy calculations can be easily done for the heat loss that occurs in winter and the amount of heat input required to keep the temperature up.

But calculations to estimate the amount of cooling required for ice making, or to maintain a cold building during the summer, are more difficult and should only be attempted by a qualified consultant.

The rate at which heat flows through different materials is called that material's conductivity, which is determined by the make-up of the material.

A board made up of the material, which has a certain thickness and conductivity, will conduct heat at a fairly consistent rate. This is called the conductance of the board. The higher the conductance, the more heat will be transported (by conduction) through the board. A common method of expressing conductance is by taking its inverse, which is the familiar resistance (R-value in imperial units, RSI in metric units) to heat flow.

#### Calculating heat loss from conduction

To calculate heat loss due to conduction, use the following equation:

$$\text{Heat flow} = \frac{\text{Area} \times \text{temperature difference}}{\text{Thermal resistance}}$$

or

$$Q_k = (A \times \text{Temp diff})/R$$

When using this equation to calculate heat flow in imperial units:

- heat flow  $Q_k$  is in Btu/hour
- area  $A$  is in square feet ( $\text{ft}^2$ )
- temperature difference is in degrees Fahrenheit
- resistance is R-value.

When using metric units:

- $Q_k$  is in watts (W)
- $A$  is in square metres ( $\text{m}^2$ )
- temperature difference is in degrees Celsius
- resistance  $R$  is in RSI.

Thermal bridging, short circuiting the insulation, is often related to the structure going through the insulation. The calculation that is required to determine the exact effect is somewhat complicated and should be carried out by a consultant, but there are counterbalancing factors as well. The resistance of the interior and exterior sheathings, and even the resistance of the still air on the interior and exterior surface of the building add to the overall resistance. The resistance of the assembly is also affected by the quality of its construction and installation of the insulation.

The amount of heat carried by air currents brushing against the interior and exterior surfaces of the building is best calculated by estimating the equivalent conductive resistance. This is termed the surface film resistance and can be used in the calculation of the assembly conductive resistance, although the added effect will be small.

Radiant barriers on insulation do not add much resistance to a well insulated building envelope. The reason is that a well insulated building envelope in winter will have interior and exterior surface temperatures close to the ambient conditions on either side. There will be some benefit from radiant barriers that protect against heat gain. The exception to this is of course windows. Making the window opaque or reflective to heat radiation decreases the amount of heat transmission through the window and increases the comfort level next to the window. This is how some newer windows get increased R-value, which all such windows note in their advertisements.



## Calculating heat flow caused by air leakage

The equation to calculate the amount of heat flow due to air leakage is:

$$\text{Heat flow} = \text{Volume flow rate} \times \text{air density} \times \text{heat capacity of the air} \times \text{temperature difference}$$

or,

$$Q_a = V \times d \times c_p \times \text{temperature difference}$$

Where:

- heat loss is in watts
- V is in litres per second (L/s)
- temperature difference is in degrees Celsius.

The heat capacity of the air is the amount of heat that the air can hold per degree of temperature. It is expressed in kilograms or pounds of air per degree of temperature.

Using imperial units and average temperatures for the equation above yields:

$$Q_a = V \times 0.0178 \times \text{temp difference}$$

Where:

- heat loss is in Btu/h
- V is in cubic feet per hour (cfh)
- Temp difference is in degrees Fahrenheit.

Calculating the amount of energy loss in ventilation is exactly the same as for air leakage. If heat recovery is used on the ventilation exhaust air, then you must multiply the total air volume by the fraction of unrecovered energy.

Heat recovery ventilators (HRVs) are becoming common appliances in energy efficient homes, and similar units are available for larger municipal and institutional facilities. HRVs are rated according to their effectiveness in recovering exhaust heat. The higher the effectiveness, the higher the heat recovery. Check the main body of the guidelines for details on HRVs and other mechanical equipment that can reduce energy consumption.

## Four methods of heat flow

There are basically four methods of heat flow that have to be considered for buildings. They are:

- conduction across all the building assemblies, such as walls, ceilings, floors, windows and doors;
- air leakage (infiltration);
- ventilation heat losses;
- radiation (solar).

The effect of radiation on the building envelope can be calculated using the SolAir temperature in the conduction calculations. This is explained in the ASHRAE Handbook of Fundamentals.

Calculations for energy transfer between interior surfaces, by radiation, should be done when the surface temperatures differ between assemblies, such as for the ceiling and ice surface. Detailed calculations, where required, should be done by a qualified consultant.

## Energy programs

Simplified energy programs can be run on most home computers. These generally work best and most accurately for buildings that require heating only, because it is too difficult to estimate the exact effect of heat gains from people (who give off heat depending on their activities) and equipment (which may run only intermittently).

The simplest programs require information about the building envelope, such as the areas of the walls and various R-values. This type of information is required for all the different components that make up the building envelope, that is all the walls, the ceiling or roof, the different areas of the floor, and such elements as the windows and doors.

One of the most popular programs is used in the R-2000 housing series put on by Natural Resources Canada and the Canadian Home Builders Association. It is called HOT 2000.

This program was designed to model houses, but can be used for buildings that have little or no ventilation systems and are under 8,000 square feet.

# APPENDIX 4:

## Power factor correction

Power factor can be described as the ratio of power actually used by a customer to the power supplied by Manitoba Hydro.

Typically, it ranges from about .7 to more than .95. The higher your power factor, the harder your electricity works for you and the lower your costs for power.

You can often improve your power factor by adding relatively inexpensive components, usually industrial capacitors, to lower your electricity bills by as much as 20 per cent.

Power factor correction is of concern to commercial or industrial customers whose plant equipment includes large three-phase electric motors and is demand metered.

If your plant's power factor is poor, Manitoba Hydro must supply more electrical capacity than your equipment actually requires. Manitoba Hydro recovers the cost of providing this extra capacity through demand charges that are a part of the electricity charges on your power bill.

Power factor (PF) is the name given to the ratio of the real useable power measured in kilowatts (kW) to the total power (real plus reactive or magnetizing power) measured in kilovolt-amperes (kVA).

*Power factor. The higher your power factor, the more useful work you are getting for your electricity dollar.*

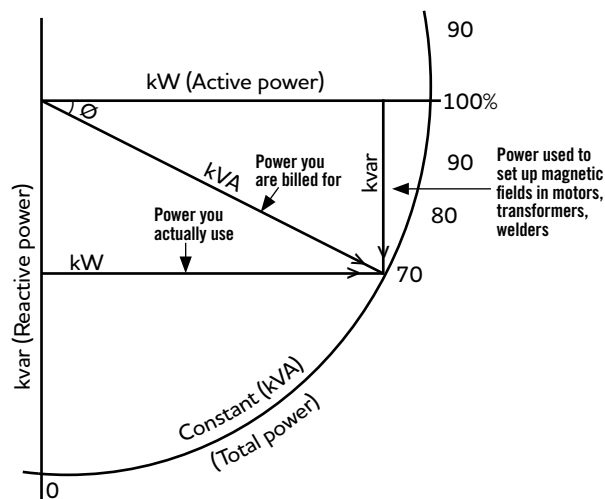

Transformers, induction motors, lighting that uses iron core ballasts, and other electro-magnetic devices must be magnetized in order to function. The current through each of these devices consists of two components – real and reactive. The real current does the useful work and develops the power required, while the reactive current establishes magnetic fields. Magnetic current contributes nothing to the work output and actually places hardship on the supply system. The total current is the vector sum of the real current and the reactive current.

The power factor of a system may be described as either lagging or leading, depending on whether the reactive power is inductive or capacitive. Most common motors, transformers, welding machines and inductive heating coils produce lagging power factor. Resistive loads, such as heaters, ranges and incandescent lights, have a perfect power factor of 100 per cent. Capacitors and some synchronous motors produce leading power factor.

Lagging power factor can be corrected by connecting capacitors to the system. The current which flows in a capacitor produces a leading power factor. This current flows in the opposite direction to that in an inductive device. When the two circuits are combined, the effect of capacitance tends to cancel the effect of inductance.

The problem is to select the proper amount of capacitors to produce the optimum cost effective saving. Too little will not correct to as sufficiently high power factor and too much will cause the power factor to deteriorate in the leading mode with the same undesirable effects.

## Measuring power factor

Manitoba Hydro will, on request, provide an accurate instantaneous measure of power factor. As a first step, you, the customer, can determine a rough instantaneous value from your demand meter. This value will indicate the advisability of further and more accurate measurement.

### Use this formula:

$$\text{Power factor} = \frac{\text{kh} \times 3600 \times 100\%}{\text{multiplier} \times \text{demand} \times \text{time}}$$

kh = value read from meter face (typically 1.08)

multiplier = the internal multiplier of your meter (typically 2)

demand = present demand reading in volt amperes

time = number of seconds for one disc revolution

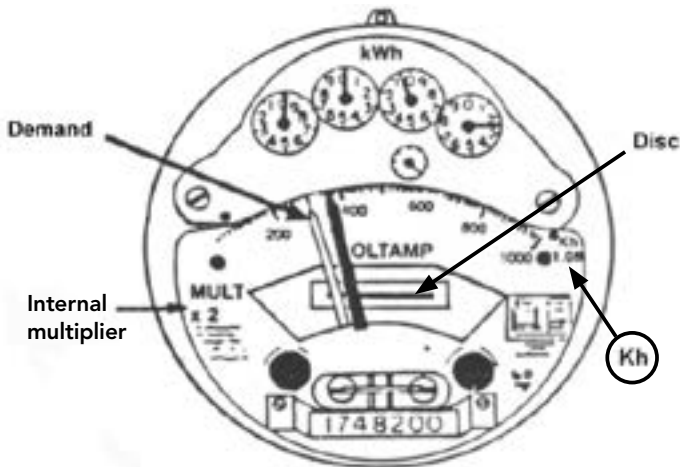

*Demand meter showing the multiplier and other parameters that you will need to get a rough idea of the power factor for your operation*

### Example:

Based on the meter readings below and an assumed time

$$\text{kh} = 1.08$$

$$\text{multiplier} = 2$$

$$\text{demand} = 300 \text{ volt amperes}$$

$$\text{time} = 80 \text{ sec. for 10 rev.} = 8 \text{ sec. per rev.}$$

$$\text{power factor}$$

$$= \frac{1.08 \times 3600 \times 100\%}{2 \times 300 \times 8}$$

$$= 81\%$$

An installation with this power factor requires a closer look and more accurate measurement,

Note that:

- Power factor is instantaneous.
- It is a value for the whole installation.
- It is important that the readings be made during a time of peak demand. Readings must be taken at least 15 minutes after the last major load change.

## Advantages of power factor correction

**Reduced demand charges.** The demand portion of all Manitoba Hydro customers is billed on measured kVA (real and reactive power) based on the highest registered demand recorded on the demand meter. Increasing the power factor will decrease the measured kVA, lowering the demand and therefore your monthly bill.

**Increased load carrying capability of circuits.**

Loads that draw reactive power also demand reactive current. Installing capacitors on the ends of circuits near the inductive loads reduces the amperage on each circuit. In addition, the diminished current flow reduces resistive losses in the circuit.

**Improved voltage.** Low power factor results in a higher current flow for a given load. As line current increases, there is a greater voltage drop in the conductor, which may result in poor voltage at equipment.

## Disadvantages of power factor correction

- Capacitors consume energy at the rate of 0.5-1.0 watt per kVAR.
- Slight voltage increase can be expected.
- Blown fuses due to resonance occurring with rectifier circuits in the system.
- Harmonic(s) distortions produced by variable speed drives or other equipment which alters the normal A/C wave can be magnified when capacitors are used.

## Savings from power factor correction

The most popular method of improving power factor is to install capacitors at the main distribution point, bus, or motor control centre for small motors or at individual large motors.

Every customer will experience a different level of cost reduction due to power factor correction, depending on the situation.

Example:

Maximum demand: 100 kVA

Minimum power factor : 80%

Assume power factor correction to 95%

Calculate kW:

$$100 \text{ kVA} \times 80\% = 80 \text{ kW}$$

With desired P.F. = 95%, kW still equals 80, but

$$\text{kVA} = 80 / 0.95 = 84$$

The approximate capacitance (kVAR) required is:

$$\sqrt{100^2 - 80^2} - \sqrt{84^2 - 80^2} = 34$$

Capacitors cost about \$100/kVAR installed.

Savings:

$$100 \text{ kVA} - 84 \text{ kVA} = 16 \text{ kVA}$$

$$\text{Demand charges are } 16 \text{ kVA} \times \$9.45/\text{kVA} \\ = \$151.20/\text{month}$$

$$\text{Payback period} = \frac{\text{total cost of installation}}{\text{annual savings}}$$

$$= \frac{\$3,400}{\$151.20/\text{month} \times 8 \text{ months per season}} \\ = 2.8 \text{ seasons}$$

### In summary:

- **Power factor correction means lower power bills.**
- **System power factor should be maintained at or greater than 90 per cent lagging.**
- **Where economically feasible, install capacitors to improve the power factor to the optimum 95 per cent.**
- **Size motors to closely match the load they will carry.**
- **Capacitors, when properly applied, are the main components used for power factor correction.**

## APPENDIX 5:

### Heat pumps for rinks and arenas

Would a heat pump system for heating, cooling and refrigeration reduce the energy costs in your community's hockey or curling arena or community hall?

Would it be better to buy a conventional refrigeration plant or maintain your current refrigeration and heating system instead?

To help you answer these questions, here is a brief look at a hypothetical example of a curling rink in southern Manitoba that uses a conventional refrigeration system in need of upgrading.

It discusses the advantages and disadvantages of installing a ground-source heat pump (or GeoExchange System). It also covers a range of related situations, in case you are starting from scratch or have questions about a hockey arena rather than a curling rink.

#### Moving heat vs generating it

A heat pump does not create heat by burning fossil fuels or circulating electricity through a heating element. It simply moves or "pumps" heat from one location to another.

In fact, a conventional refrigeration system for making ice in arenas and curling rinks is a type of heat pump. It makes ice by moving heat from under the rink slab to an evaporative or air-cooled condenser. Outside air dissipates the heat to the atmosphere.

#### Arenas and community halls

Heat pumps, which are used to create ice for rinks and arenas and warm viewing areas, work extremely efficiently by using the ground around the building to collect or dissipate heat.

Such heat pumps, known as ground-source heat pumps, use a network of pipes, often carrying a mixture of water and methanol, buried in the ground.

When one or more heat pumps are making ice or providing air conditioning, they move heat from the rink pipes or the interior of the building to the fluid circulating in pipes in the ground through a heat exchanger. The result is that the earth surrounding the pipes becomes warmer. An additional fluid cooler may be required to ensure the ground does not become too warm when making ice in the fall or if an extended ice season is required.

When another heat pump, usually one separate from ice-making heat pumps, is used to warm a viewing area or produce hot water, it removes heat from the earth by removing heat from the fluid in the buried pipes.

Ground source heat pumps may involve runs of up to several thousand feet of 1 1/2-in. high-density polyethylene pipe. Depending on soil conditions and the amount of room available, the pipe may be buried in a horizontal network several feet down or in a series of vertical loops from 80-200 ft. deep.

The initial cost of installing the pipe is high, to ensure the integrity of the piping over the lifetime of the system. Once installed, the network of pipes enables the overall system to be one of the most economical from an energy viewpoint.

#### Why are heat pumps so efficient

In a conventional oil, propane, or natural gas furnace, approximately 40 per cent of the energy from the fuel burned to produce heat or operate the pilot light is exhausted straight up the chimney, making the furnace 60 per cent efficient. Mid- and high-efficiency furnaces are somewhat better, at 80-95 per cent. Electric heat is considered 100 per cent efficient.

Compared with electric heat, ground source heat pumps are far more efficient. Because they move heat from one place to another, rather than creating it through combustion or electric elements, they deliver 200 to 300 per cent more heat than you could obtain from an equivalent electric heating system.

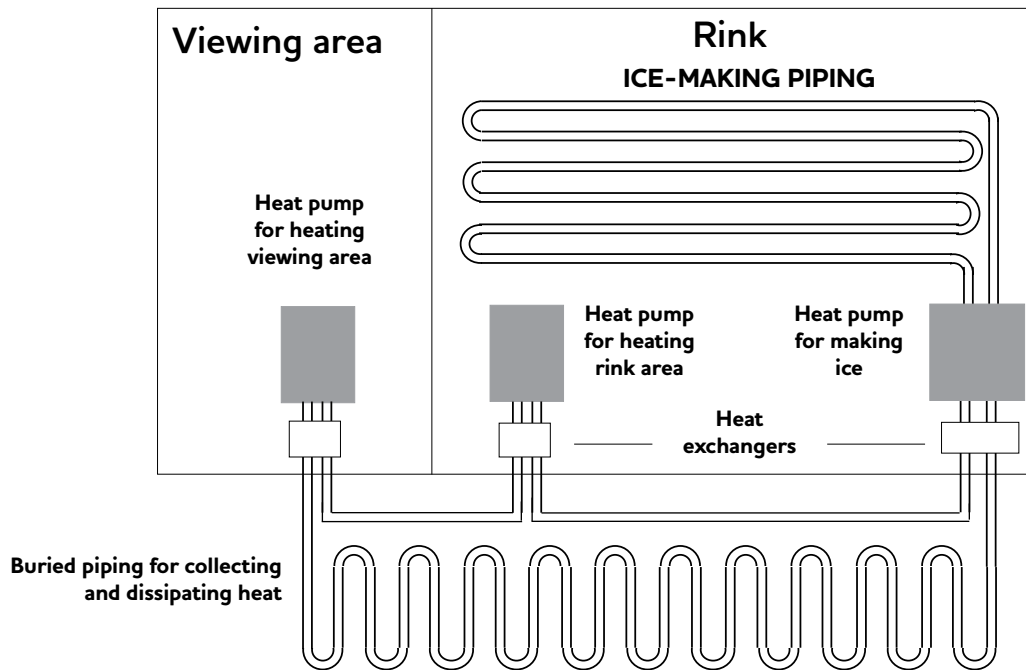

*Heat pump system for a hypothetical example of a curling club.*

## A curling club looks at their options

In this hypothetical example, a curling club weighs the option of installing a ground-source heat pump as compared with replacing their existing plant or using the existing plant and recovering some of the heat. The heat from the existing compressor could be used to heat hot water, the dressing rooms and melt snow but when the outside temperature is the coldest and heat is needed the most, the compressors may seldom run.

The club's 20-year-old conventional refrigeration system is showing its age, raising questions of whether or not to rebuild the old compressor, replace it with another conventional system, or replace the entire system with a ground source heat pump. Replacing the old compressor with a remanufactured unit would be the least expensive but would not allow the club to enjoy the advantages of lower heating and cooling costs that a heat recovery system would provide. The club eventually decides to investigate a new ground-source heat pump to make ice, along with added insulation under the rink slab and separate smaller heat pumps for warming or cooling the building.

The project cost is estimated at between \$70,000 and \$100,000, compared with \$6,000 – \$12,000 for replacing the old compressor with a remanufactured unit.

Taking into account savings in maintenance and electricity, and the help of an incentive from Manitoba Hydro, the project can be expected to pay for itself in seven to 18 years.

Here is a brief look at the project, to give you some idea of the economics of switching to heat pumps or sticking with an old system.

## Background on the club

The curling club occupies an 1,120 sq. m (12,000 sq. ft.) single-story building.

The building houses a three-sheet curling rink overlooked by a lobby and viewing area 10 m by 15 m. A second floor lounge above the lobby accommodates up to 150 people.

The viewing area includes concessions, offices, change rooms and a mechanical room. The lobby and the second floor lounge are heated by electric forced air furnaces. In the rink area, electrical forced flow unit heaters suspended from the ceiling keep the temperature just above freezing for curlers.

The rink floor is packed earth over rink piping, with no insulation underneath. The club often has problems keeping ice because of frost heaving.

The club's electricity bill averages about \$8,000 a year. This includes the energy needed to operate the refrigeration system, lighting, electric heat and other miscellaneous uses.

The rink usually operates from mid-October until the end of March. During the summer, the building is used very little. If the second floor lounge was air conditioned, some additional revenue could be earned from hall rentals.

## **Savings on making ice depend on insulation upgrade**

The annual cost of electricity to operate a conventional refrigeration system in this building is \$3,000. Electricity is needed to operate a 30-hp compressor, a 7.5-hp brine circulation pump and a 3-hp fan motor for the outdoor air-cooled condenser.

The temperature of the ice controls the compressor and condenser fan. The brine pump runs continuously to maintain consistent, even ice temperatures. The brine pump could be cycled using an ice slab thermostat but the icemaker worries that this will adversely affect the condition of the ice. A compromise would be to cycle the pump when the ice is not being used and run the pump continually during times the rink is in use.

The ground temperature in Manitoba averages about 5–6 C (41–43 F). Without insulation under the ice, heat from the ground adds significant heat load to the system, requiring the plant to run more.

Placing 75–100 mm of high-density foam insulation under the floor reduces the heat gain from the earth by about 90–95 per cent.

The thickness of the sand or concrete in most hockey or curling arenas is usually 10 to 15 cm, placed on top of insulation. When the ice is in use, heat from the lights, people using the rink, flooding the ice, and the heating system warms the ice, forcing the refrigeration system to start up to maintain the ice temperature.

A special new floor design increases the thickness of the floor from 6 to 8 times compared with a conventional floor to form a cold storage buffer under the regular piping in the concrete slab.

The buffer includes a second layer of pipe that allows heat pumps to chill the buffer during off-peak hours for demand savings and hold the ice even during a mild spell of several days.

In the hypothetical example of the curling rink, adding insulation to the rink floor, taking advantage of the thermal storage buffer with smaller circulation pumps, and replacing the condenser fan with a much smaller circulation pump reduces the estimated energy consumption needed to make ice from \$3,000 to approximately \$1,800, for annual savings of \$1,200.

## **Savings on heating the rink and viewing area**

The club spends \$5,000 a year on electricity to heat the viewing and lounge areas and the rink area. A ground-source heat pump system typically reduces heating costs by 60–65 per cent compared to electric heat.

Because of the greater efficiency of ground source heat pumps over electric heating elements, switching to heat pumps instead of the electric furnaces and unit heaters would reduce the club's annual \$5,000 heating bill by about 60 per cent, to \$2,000.

## **Savings on heating and ice-making**

In summary, using ground source heat pumps to heat various parts of the building and make ice under a slab with upgraded insulation would cut the club's heating bills from \$8,000 to \$3,800—just over 50 per cent—for annual savings of \$4,200.

## **Savings on maintenance**

Operation and maintenance costs are significantly lower with a heat pump system than with a conventional, refrigeration system. In the case of the hypothetical curling rink, annual savings would be approximately \$1,400 – \$3,100.

Here are the details. Conventional refrigeration equipment is designed for industrial applications and lasts many years. However, to ensure reliability, the compressor must be rebuilt regularly. Manufacturers of this type of equipment recommend that the compressor be dismantled to replace worn parts every 8,000 – 10,000 hours of runtime; typically every four to six years in most facilities. The cost of rebuilding this type of compressor is about \$4,000 – \$6,000. As a result, maintaining the compressor in a three-sheet curling rink can total \$16,000 – \$24,000 over 20 years, or \$800 – \$1,200 a year.

Chiller barrels, outdoor condensing units, and circulation pumps require maintenance as well. To replace a chiller barrel for a small curling club can cost \$15,000 – \$20,000. An outdoor condensing unit costs about the same. A 7.5 hp brine pump can be replaced with a new unit for about \$3,000. Maintenance and replacement costs can total \$30,000 – \$45,000 over a 30-year period, or about \$1,000 – \$1,500 per year.

A conventional ice-making system requires an operator trained to run it properly. Manufacturers recommend checking system operation at start-up and shutdown to ensure reliable operation, just like the engine in your car. They also recommend that you follow proper start-up and shutdown procedures. Systems should be started and shutdown by a qualified person. The cost of a specially trained technician to perform these procedures can easily range \$500 – \$1,500 a year.

Most systems in Manitoba use calcium chloride brine as the antifreeze to circulate through the system. The acidity of the brine must be monitored regularly to prevent corrosion of the chiller barrel and pumps.

If ammonia is the primary refrigerant, oil that collects in the chiller barrel must be drained regularly to prevent a loss of efficiency and to ensure lubrication of the compressor. Refrigerant pressures must be checked regularly.

In summary, the total average operation and maintenance cost of a conventional ice plant in a small curling club can easily average \$2,300 – \$4,200 a year.

In a heat pump system, the compressors are designed to last 10 or more years with very little maintenance, much like your household refrigerator. Rebuilds are not required. The fluid used in an integrated system is typically an alcohol or glycol solution, inside a pressurized, sealed system. There is little chance of oxygen entering the system, and much less chance of corrosion inside the heat exchangers or pumps.

For a heat pump system, start-up and shutdown procedures are relatively simple, not much more elaborate than plugging in a refrigerator or starting your home air conditioner. Oil levels do not require monitoring.

To replace the complete heat pumps and circulation pumps in a three sheet curling rink after 15 or 20 years would cost from \$18,000 – \$22,000, or an average of \$900 – \$1,500 a year. In most rinks, however, the compressors only can typically be replaced for \$6,000 – \$8,000.

In summary, operation and maintenance costs should be significantly lower with a heat pump system than with a conventional, refrigeration system. Annual savings with a heat pump system would be approximately \$800-\$3,300.

## **Total savings on maintenance and electricity**

Using a heat pump system rather than a conventional refrigeration system would save \$4,200 a year for electricity and \$800 – \$3,300 a year of reduced maintenance, for total savings on maintenance and electricity of \$5,400-\$7,500 a year.

## **Installing a heat pump/insulation upgrade a major expense**

For a three-sheet curling rink, installing a ground source heat pump system, including upgrading insulation under the rink slab, would cost about \$70,000 – \$100,000.

In contrast, upgrading and maintaining the existing conventional refrigeration system would cost \$6,000 to \$12,000.

As a result, installing a heat pump system rather than replacing the existing conventional refrigeration system, because it involves an insulation upgrade, would cost an additional \$58,000 – \$94,000.

A Power Smart\* incentive under Manitoba Hydro's Commercial Geothermal Program would reduce the difference by about \$4,000, lowering the cost to the range of \$54,000 – \$90,000.





## Rink floors with thermal storage buffer

In many hockey and curling rinks the ice surface is built by laying polyethylene pipe on a sand surface. Most rinks built in the last twenty years included a 3-4 in. (75-100 mm) thickness of high-density foam insulation a couple of inches below the surface to slow the transfer of heat from the warm ground. In a facility used during the off-season for other uses such as inline hockey or lacrosse, a 4-6 in. (100-150 mm) concrete surface is used in place of the sand.

A patented rink floor design with a thick layer of dense material and a second layer of pipe between the pipe at the rink surface and the insulation provides significant benefits to the operation of the rink.

### Ability to shift peak demand

The large mass of the thickened floor can be cooled several degrees cooler than the ice surface at night, when the ice is not used. The heat taken from the floor can be used to warm the building. The chilled floor absorbs a large portion of the heat from the ice the following day. Basically, the building is heated tonight with tomorrow's refrigeration.

### Greater capacity to hold the ice

If an ice storm interrupts the power supply to the facility, the large mass of the thick floor will absorb enough heat to maintain the ice for several days, eliminating the need to rebuild the ice surface. Or, if a pump or a compressor fails, the stored cold will maintain the ice until repairs are made.

### More even ice temperature

The ice on a conventional rink floor is maintained only by the chilled fluid circulating through the pipes just under the ice. When a second layer of pipe is buried in a thick layer of dense material directly under the ice surface, the whole floor chills the ice. The ice temperature is more consistent because the space between the pipes is as cold as the fluid circulating through the pipes at the surface.

*Conventional rink floor. Lack of thermal cold storage requires substantial ice-making capacity.*

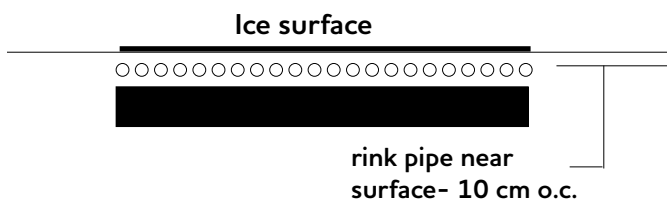

The temperature of the large mass of the thick floor is more difficult to change than the temperature of a conventional floor. This is similar to using a heavy cast iron frying pan rather than an inexpensive, light aluminum pan. The large mass creates more consistent, more uniform ice temperatures.

A rink floor is usually designed to remove heat from the ice under the heaviest use. A conventional rink floor relies strictly on the fluid circulated through the pipe immediately under the rink surface to take away all of the heat. Enough fluid must be circulated to remove all of the heat. This requires a sufficiently large circulation pump. Typically, a three-sheet curling rink with a conventional floor will require a 7 1/2 or 10 hp brine pump. A full size hockey rink with a thin floor usually requires a 15-25 hp brine pump.

### Smaller brine pump/ smaller ice plant

The mass of the thick floor changes this. A large portion of the heat load on the ice is absorbed directly by the frozen buffer. By reducing the amount of heat that has to be removed by the fluid circulating through the rink pipe, the size of the pump can be reduced.

A 2 or 3 hp pump working with the thermal storage buffer absorbs the heat on a three-sheet curling rink. Depending on the use of the hockey rink, one, two, or three 3-hp pumps combined with a thick floor will provide the refrigeration needed during heavy use.

When the concrete floor needs to be replaced in 10 or 15 years, the thermal storage buffer can be installed.

Thermal storage buffers can be installed without a concrete floor. Several rinks in Manitoba and Saskatchewan have been built with only the pipe in the thermal storage buffer, because of budget constraints. After a few years, when the financial resources become available, the concrete floor can be added as the second phase of the project.

*Rink floor with a thermal storage buffer. The buffer helps maintain constant ice temperature. It also allows the heat pumps to chill the buffer during off-peak hours for demand savings.*

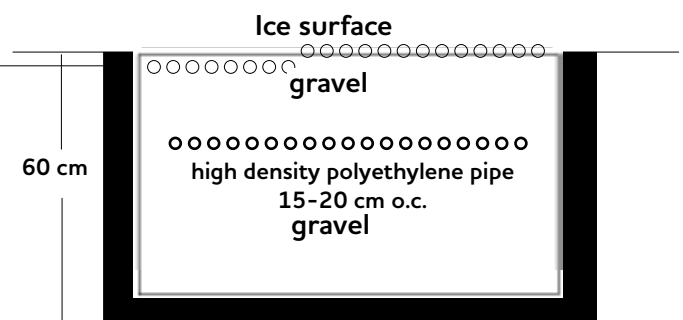

## New rink

The time to take full advantage of a heat pump heating and refrigeration system is during the design stages.

The thermal storage buffer is easily installed during the original construction of the building, with very little additional cost. An efficient radiant floor heating system can be installed in the building very cost-effectively during construction. In addition, an effective snowmelt pit is easily installed at this time. Even pipe to melt snow and ice at the front entrance can be installed inexpensively during construction.

To find the most cost-effective approach, it is important that everyone involved in the project come together very early in the design process. The owner, the building designer, the general contractor, the mechanical contractor, and the equipment supplier can all provide valuable input into the process, and find the most cost-effective ways to reach the final goal – an efficient, user-friendly recreational facility.

It is important to understand that the insulation in the building, the type of lighting, the type of heat distribution system, the ventilation, and even the type of ice resurfacing equipment can all have a dramatic impact on the overall energy efficiency, operating and maintenance costs, and comfort of the building.

## Curling rinks, hockey arenas and other buildings

The advantages of a heat pump heating and refrigeration system are apparent in any building with simultaneous heating and chilling requirements, regardless of whether the ice is used for hockey, figure skating, curling, or broomball.

The thermal storage buffer provides consistent ice temperatures with reduced energy costs for either a hockey or curling arena. In fact, the integration of the building systems can provide huge benefits even in buildings without hockey or curling ice.

For example, ice can be built in storage tanks in a building to provide air conditioning during peak loads. The heat removed while the ice is being made can provide space heating or hot water for use in the building.

## Demand savings – A big advantage of heat pumps

Charges for electricity at facilities such as arenas and community halls are generally based on the greatest amount of electricity used during any 15-minute period throughout the month. The greatest amount of electricity is known as “peak demand.”

By lowering peak demand, users can substantially lower their electricity bills.

One way to keep peak demand down is to shed unnecessary loads during times of the day when demand for electricity is highest. Unnecessary loads may include domestic hot water heating, parking lots, large motors, and lighting.

The integration of the refrigeration system, the heating system, the thermal storage buffer, and the energy storage capacity of the earth provide significant electrical demand reductions. During the night when electrical demand is low, heat pumps—which are small in capacity compared with conventional refrigeration systems—work long hours to withdraw heat from the cold storage buffer.

After overnight cooling, the storage buffer can “hold” the ice during the day, making it possible to turn off the ice-making heat pumps during peak times when the building is heavily used. The result can be a significant saving on electricity bills.

## Heat recovery with the old system

Most conventional ice-making plants waste the heat drawn from ice making by dissipating it to the outdoors. But they can be configured to use this normally wasted energy. Instead of dissipating the heat to the air the way coils on the back of a domestic refrigerator dissipate their heat to the kitchen, the heat can be transferred to a large tank filled with water.

The warm water can be circulated through pipes to provide space heating as a supplement to electric or other types of heating. It can also be used to generate domestic hot water or warm flooding water, and even hot air to hand driers in washrooms.

The problem is that when the heat is needed most, during very cold weather, the ice plant does not release much heat because it does not need to work as hard to make ice. Similarly, in warm weather, when the extra heat is not needed, the ice plant produces the maximum amount of heat because it is hard at work making ice.

With a geothermal heat pump system, the earth loop acts like a sponge, absorbing excess heat when it cannot be used for space heating or making hot water. When the ice temperature is satisfied, the earth loop provides a source of heat for the system, eliminating the need for fossil fuel furnaces or electric heaters.

## Additional energy saving options

The following energy saving options apply to curling rinks, arenas, and community halls, regardless of whether they use conventional refrigeration systems or heat pumps:

- energy efficient lighting;
- low e ceilings;
- high efficiency motors;
- upgrade insulation and air tightness during building envelope maintenance or renovations;
- parking lot controllers;
- demand and energy metering;
- operational improvements, such as higher brine temperature, reduced ice thickness, and reduced floodwater volume and temperature;
- alternative heating fuels.

For more details contact your local Manitoba Hydro Energy Services Advisor.

## Cost worksheets: heat pumps vs conventional systems

The true costs of installing, operating, and maintaining a refrigeration system and HVAC system may be difficult to determine.

**Hidden installation costs.** Some of the installation costs may not be readily apparent. For example, the cost of installing equipment on the roof of a building must include the increased structural cost to support the equipment, the openings on the roof, and the increased maintenance costs and decreased lifetime of equipment exposed to the harsh Manitoba climate.

These system costs may not be included directly in the cost of the mechanical system. They may be hidden in the structural section of the building budget.

**Room for ammonia.** Because of the toxicity of ammonia, equipment using it as the refrigerant are subject to much more stringent code requirements than equipment using other refrigerants. An addition to the building may be needed to house equipment using ammonia refrigerant. Equipment using a safer refrigerant can often be installed in existing space within the building.

**Specially trained personnel.** The cost of hiring a specially trained technician to start up the system in fall and shut the system down properly in springtime should not be overlooked. The size of the compressors and motors used in some systems may require a more highly trained and highly paid operator than a system with smaller modular units.

**Maintaining an evaporative condenser vs ground loop.** The cost of maintaining an evaporative condenser used in a cold climate can be significant in comparison to the cost of maintaining an earth loop buried under a field next to the rink.

**Scheduled maintenance for refrigeration equipment.** Large industrial equipment, though very durable and long lasting if properly maintained, requires scheduled maintenance to maintain dependable performance.

**Implications of a failure.** Think about the implications of the failure of a key component of a system. If a pump fails, how long will it take before a replacement pump can be installed? Will expensive, overtime service rates be incurred if it fails on a holiday?

These issues should be taken into consideration when deciding on the type of refrigeration and heating system to install in a new facility or to replace an existing system.

If possible, visit facilities and speak to the operators and owners of systems installed similar to yours. What is the track record of the supplier and installer of the system?

Check the following chart for questions that should be asked when deciding on the system.

---

## Typical costs to determine when considering a heat pump system

---

### PROJECT COSTS

	<b>Ground source heat pump system</b>	<b>Conventional system</b>
1. Low-temperature heat pump to make ice	_____	_____
2. Ground-source heat pumps for HVAC/ducting	_____	_____
3. Circulation pumps for the ice and earth loops	_____	_____
4. Vertical earth loop	_____	_____
5. Controls	_____	_____
6. Rink floor installation	_____	_____
7. Excavation for rink floor	_____	_____
8. Insulation under rink floor	_____	_____
9. Labour	_____	_____
10. Conventional ice plant	_____	_____
11. Addition to house ice plant	_____	_____
12. Upgrade for electrical service	_____	_____
13. Utility incentives	_____	_____
<b>TOTAL PROJECT COSTS</b>	_____	_____

### Annual OPERATING AND MAINTENANCE costs

	<b>Ground source heat pump system</b>	<b>Conventional system</b>
1. Energy cost for the rink and hall	_____	_____
2. Annual service, including start-up and shutdown	_____	_____
3. Daily maintenance (1.5 hours/day)	_____	_____
4. Ice maker operating personnel (6 months/year)	_____	_____
5. 6000 hour check (every 3-4 years; cost/year)	_____	_____
6. 12,000 hour check (every 6-8 years; cost/year)	_____	_____
7. Heat pump replacement (once in 20 years)	_____	_____
8. Circulation pump replacement (once in 20 years)	_____	_____
9. Chiller, header, condenser (once in 20 years)	_____	_____
10. Replace HVAC system (once in 20 years)	_____	_____
<b>TOTAL ANNUAL O &amp; M COSTS</b>	_____	_____

## APPENDIX 6:

### Power Smart Programs for commercial buildings

Manitoba Hydro offers financial assistance and technical guidance to its commercial customers to install the most up-to-date energy efficient technologies in new construction and renovation projects. With the help of incentives under Power Smart, you can often recover the cost of using approved energy efficient technologies in a few years.

Benefits include: lower heating and cooling costs, improved occupant comfort, and longer building life. In saving energy you also help save the environment. When you use less electricity, we can defer the capital cost and environmental effects of building more dams and transmission lines. We can export any surplus electricity for revenues that help keep our rates among the lowest in the industrialized world. At a global level, the electricity we export reduces emissions of greenhouse gases produced by other utilities by “displacing” emissions from their fossil fuel burning power plants.

For current information on Power Smart for Business programs and incentives:  
Visit [hydro.mb.ca/psfb](http://hydro.mb.ca/psfb)  
Contact your Manitoba Hydro account representative.  
Phone: 204-360-3676 (Winnipeg) or 1-888-624-9376  
Email: [powersmartforbusiness@hydro.mb.ca](mailto:powersmartforbusiness@hydro.mb.ca)



For more information on Power Smart for Business,  
contact your Manitoba Hydro account representative or:

**Phone: 204-360-3676 (Winnipeg) or 1-888-624-9376**

**Email: [powersmartforbusiness@hydro.mb.ca](mailto:powersmartforbusiness@hydro.mb.ca)**

**Visit: [hydro.mb.ca/psfb](http://hydro.mb.ca/psfb)**

June 2016

 Printed on recycled paper

